

## ► PSWZ X1P

**PILZ**  
THE SPIRIT OF SAFETY

Operating Manual-21005-EN-14  
- Safe monitoring relays



This document is the original document.

Where unavoidable, for reasons of readability, the masculine form has been selected when formulating this document. We do assure you that all persons are regarded without discrimination and on an equal basis.

All rights to this documentation are reserved by Pilz GmbH & Co. KG. Copies may be made for the user's internal purposes. Suggestions and comments for improving this documentation will be gratefully received.

Pilz®, PIT®, PMI®, PNOZ®, Primo®, PSEN®, PSS®, PVIS®, SafetyBUS p®, SafetyEYE®, SafetyNET p®, the spirit of safety® are registered and protected trademarks of Pilz GmbH & Co. KG in some countries.



SD means Secure Digital

<b>Introduction</b> .....	<b>5</b>
Validity of documentation .....	5
Using the documentation .....	5
Definition of symbols .....	5
<b>Safety</b> .....	<b>6</b>
Intended use .....	6
Safety regulations .....	6
Safety assessment .....	6
Use of qualified personnel .....	7
Warranty and liability .....	7
Disposal .....	7
For your safety .....	7
<b>Unit features</b> .....	<b>8</b>
<b>Safety features</b> .....	<b>8</b>
<b>Block diagram/terminal configuration</b> .....	<b>9</b>
<b>Function description</b> .....	<b>9</b>
Operating modes .....	10
Timing diagram .....	11
<b>Installation</b> .....	<b>11</b>
<b>Wiring</b> .....	<b>12</b>
<b>Preparing for operation</b> .....	<b>13</b>
Connection .....	13
Set standstill detection .....	14
Application example .....	15
<b>Operation</b> .....	<b>16</b>
Status indicators .....	17
Fault indicators .....	17
<b>Faults – Interference</b> .....	<b>17</b>
<b>Dimensions in mm</b> .....	<b>17</b>
<b>Technical details</b> .....	<b>18</b>
Safety characteristic data .....	32
<b>Supplementary data</b> .....	<b>33</b>
Service life graph .....	33

<b>Order reference .....</b>	<b>35</b>
<b>EC declaration of conformity .....</b>	<b>35</b>
<b>UKCA-Declaration of Conformity .....</b>	<b>35</b>

## Introduction

### Validity of documentation

This documentation is valid for the product PSWZ X1P. It is valid until new documentation is published.

This operating manual explains the function and operation, describes the installation and provides guidelines on how to connect the product.

### Using the documentation

This document is intended for instruction. Only install and commission the product if you have read and understood this document. The document should be retained for future reference.

### Definition of symbols

Information that is particularly important is identified as follows:



#### **DANGER!**

This warning must be heeded! It warns of a hazardous situation that poses an immediate threat of serious injury and death and indicates preventive measures that can be taken.



#### **WARNING!**

This warning must be heeded! It warns of a hazardous situation that could lead to serious injury and death and indicates preventive measures that can be taken.



#### **CAUTION!**

This refers to a hazard that can lead to a less serious or minor injury plus material damage, and also provides information on preventive measures that can be taken.



#### **NOTICE**

This describes a situation in which the product or devices could be damaged and also provides information on preventive measures that can be taken. It also highlights areas within the text that are of particular importance.

**INFORMATION**

This gives advice on applications and provides information on special features.

**Safety****Intended use**

The PSWZ X1P is used for safe standstill monitoring.

The unit is designed for use with

- ▶ Standstill monitoring at plants with dangerous machine parts or tools in safety circuits in accordance with EN 602041

Standstill is only detected on power-free measuring circuits. Residual voltages, induced voltages or drives within the position control will prevent safe standstill detection!

**Improper use**

The following is deemed improper use in particular:

- ▶ Any component, technical or electrical modification to the product,
- ▶ Use of the product outside the areas described in this operating manual,
- ▶ Use of the product outside the technical details (see chapter entitled [Technical Details](#)  18).

**NOTICE****EMC-compliant electrical installation**

The product is designed for use in an industrial environment. The product may cause interference if installed in other environments. If installed in other environments, measures should be taken to comply with the applicable standards and directives for the respective installation site with regard to interference.

**Safety regulations****Safety assessment**

Before using a device, a safety assessment in accordance with the Machinery Directive is required.

The product as an individual component fulfils the functional safety requirements in accordance with EN ISO 13849 and EN 62061. However, this does not guarantee the functional safety of the overall plant/machine. To achieve the relevant safety level of the overall plant/machine's required safety functions, each safety function needs to be considered separately.

**Use of qualified personnel**

The products may only be assembled, installed, programmed, commissioned, operated, maintained and decommissioned by persons who are competent to do so.

A competent person is a qualified and knowledgeable person who, because of their training, experience and current professional activity, has the specialist knowledge required. To be able to inspect, assess and operate devices, systems and machines, the person has to be informed of the state of the art and the applicable national, European and international laws, directives and standards.

It is the company's responsibility only to employ personnel who

- ▶ Are familiar with the basic regulations concerning health and safety / accident prevention,
- ▶ Have read and understood the information provided in the section entitled Safety
- ▶ Have a good knowledge of the generic and specialist standards applicable to the specific application.

**Warranty and liability**

All claims to warranty and liability will be rendered invalid if

- ▶ The product was used contrary to the purpose for which it is intended,
- ▶ Damage can be attributed to not having followed the guidelines in the manual,
- ▶ Operating personnel are not suitably qualified,
- ▶ Any type of modification has been made (e.g. exchanging components on the PCB boards, soldering work etc.).

**Disposal**

- ▶ In safety-related applications, please comply with the mission time  $T_M$  in the safety-related characteristic data.
- ▶ When decommissioning, please comply with local regulations regarding the disposal of electronic devices (e.g. Electrical and Electronic Equipment Act).

**For your safety**

The unit meets all the necessary conditions for safe operation. However, please note the following:

- ▶ Note for overvoltage category III: If voltages higher than low voltage (>50 VAC or >120 VDC) are present on the unit, connected control elements and sensors must have a rated insulation voltage of at least 250 V.

**Unit features**

- ▶ Measuring inputs for 3- or 1-phase motors
- ▶ Measuring voltage on both channels can be set jointly
- ▶ 1 Reset input
- ▶ Positive-guided relay outputs:
  - 2 safety contacts (N/O), instantaneous
  - 1 auxiliary contact (N/C), instantaneous
- ▶ 2 semiconductor outputs
- ▶ LED display for:
  - Standstill on channel 1/2
  - Supply voltage/fault
- ▶ Semiconductor outputs signal:
  - Supply voltage/fault
  - Switch status
- ▶ Feedback loop for monitoring external contactors
- ▶ Plug-in connection terminals (either spring-loaded terminal or screw terminal)
- ▶ See order reference for unit types

**Safety features**

- ▶ The relay meets the following safety requirements:
  - The circuit is redundant with built-in self-monitoring.
  - The safety device remains effective in the case of a component failure.
  - The correct opening and closing of the safety device relays is tested automatically in each on-off cycle.
- ▶ The unit monitors the measuring circuits for open circuit. If an open circuit occurs between the unit and the motor or on the motor itself, the unit immediately switches off.
- ▶ The standstill monitor prevents the plant from being enabled in the following cases:
  - Power supply failure
  - Component failure
  - Measuring circuits are open circuit
  - Coil defect/open circuit



### Block diagram/terminal configuration

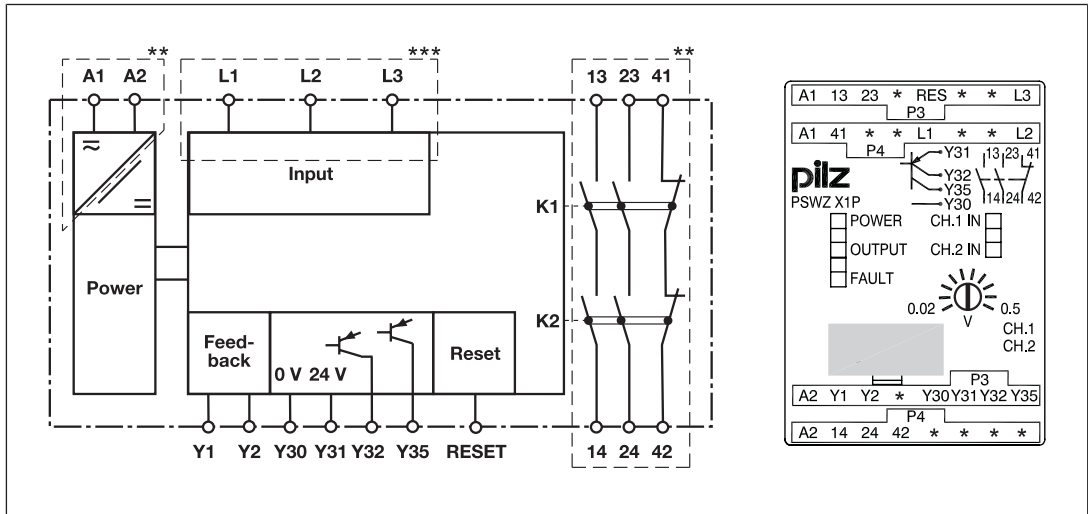

\*\*Insulation against the non-marked area and between the relay contacts: Basic insulation (overvoltage category III), protective separation (overvoltage category II); at 250 V, 4 kV

\*\*\*Insulation against the non-marked area and between the measurement connections: Basic insulation (overvoltage category III), protective separation (overvoltage category II); at 690 V, 6 kV

- ▶ Channel 1: L1-L3
- ▶ Channel 2: L2-L3



**CAUTION!**

**Touch current higher than permitted is possible**

In single-phase applications over 250 V to earth potential there is only a basic insulation, but no protective separation to the measuring inputs L1, L2 and L3.

### Function description

The device uses two separate measuring channels to measure the regenerated voltage, induced from the motor during the rundown period. If the voltage falls below the set response value (standstill threshold), the PSWZ X1P enables the monitored plant.

When used with frequency converters, the PSWZ X1P cannot detect standstill until the controller inhibit has been switched off.

After the supply voltage  $U_B$  is switched on, the unit performs a self test. The unit simulates a situation in which the release value is exceeded and the measuring circuit has an open circuit. The correct function of the output relay and feedback loop is also tested. The test takes approx. 1.5 s.

The unit is ready for operation when the feedback loop is closed and the measuring circuits are not interrupted.

- ▶ Procedure when the measuring voltage falls below the response value  $U_{on}$  on both channels L1-L3 and L2-L3:
  - LEDs "POWER", "CH.1 IN", "CH.2 IN" and "OUTPUT" are lit.
  - Safety contacts 13-14 and 23-24 are closed, auxiliary contact 41-42 is open.
  - A high signal is present at semiconductor output Y32.
- ▶ Procedure when after the motor has started, the voltage in one of the two measuring circuits exceeds the release value  $U_{off}$ :
  - Safety contacts 13-14 and 23-24 are opened redundantly, auxiliary contact 41-42 is closed.
  - A low signal is present at semiconductor output Y32.
  - LEDs "CH.1 IN", "CH.2 IN" and "OUTPUT" go out.

To reactivate, the voltage at both channels L1-L3 and L2-L3 must fall below the response value  $U_{on}$  within the time  $t_g$  (simultaneity monitoring) and the feedback loop must be closed. The response value  $U_{on}$  can be set jointly for both channels in order to suit the motor that is to be monitored. The release value  $U_{off}$  (hysteresis) corresponds to twice the response value.

If the simultaneity requirement is exceeded, the "FAULT" LED is lit and on the semiconductor output Y35 there is a High signal. The PSWZ X1P does not enable the monitored plant. The fault is reset by applying a High signal and then a Low signal at the reset input.

### **Self test**

An internal self test is carried out during initial commissioning and each time the supply voltage is switched off and on. The process simulates switching all measuring voltages on and then off again. Provided no error occurs during the self test, the unit will then be ready for operation.

### **Operating modes**

- ▶ Single-phase operation:
  - One measuring circuit (calculated at two different measuring points) affects both channels
- ▶ Three-phase operation:
  - Two redundant (identical) measuring circuits affect channel 1 and 2
  - Voltages in the measuring circuit are monitored (failsafe in the event of a short circuit)

### Timing diagram

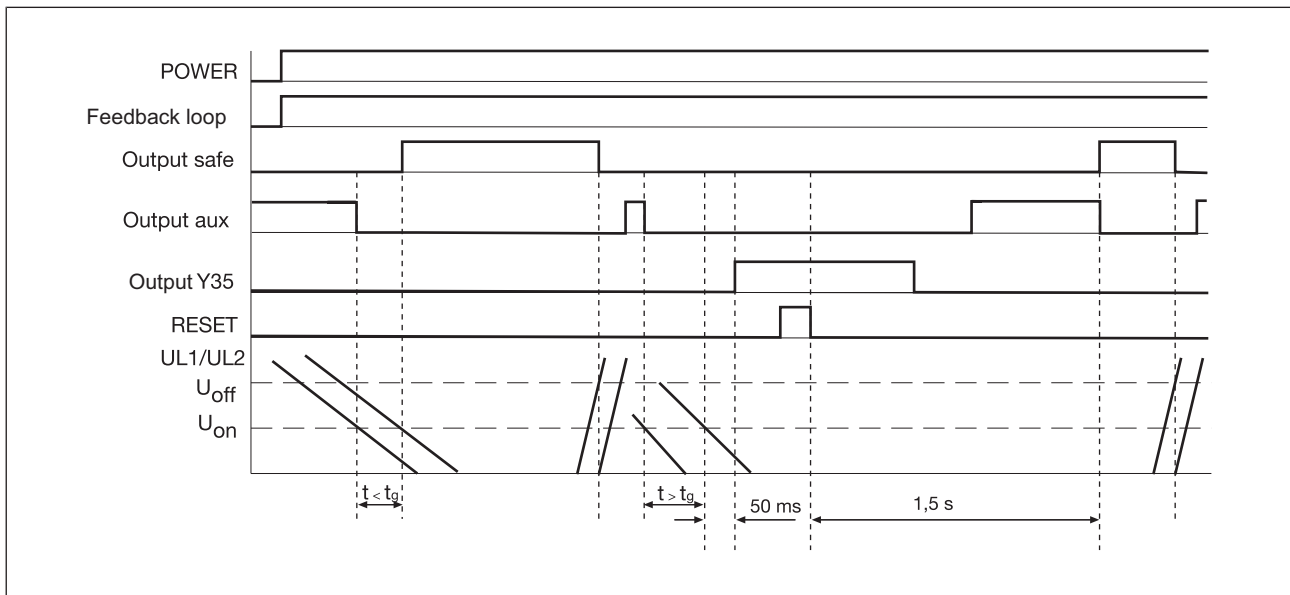

### Legend

- ▶ POWER: Supply voltage
- ▶ UL1/UL2: Input circuit L1, L2, L3
- ▶ Feedback loop: Feedback loop Y1-Y2
- ▶ Output safe: Safety contacts 13-14, 23-24
- ▶ Output aux: Auxiliary contact 41-42
- ▶ Output Y35: Semiconductor output for fault signal
- ▶ RESET: Reset input
- ▶  $U_{on}$ : Response value
- ▶  $U_{off}$ : Release value
- ▶  $t_g$ : Simultaneity

### Installation

- ▶ The unit should be installed in a control cabinet with a protection type of at least IP54.
- ▶ Use the notch on the rear of the unit to attach it to a DIN rail (35 mm).
- ▶ When installed vertically: Secure the unit by using a fixing element (e.g. retaining bracket or end angle).

## Wiring

Please note:

- ▶ Information given in the "[Technical details \[18\]](#)" must be followed.
- ▶ Outputs 13-14, 23-24 are safety contacts, the output 41-42 is an auxiliary contact (e.g. for display).
- ▶ Auxiliary contact 41-42 should **not** be used for safety circuits!
- ▶ To prevent contact welding, a fuse should be connected before the output contacts (see [Technical details \[18\]](#)).
- ▶ Calculation of the max. cable length  $l_{\max}$  in the input circuit:

$$l_{\max} = \frac{R_{l_{\max}}}{R_l / \text{km}}$$

$R_{l_{\max}}$  = max. overall cable resistance (see [Technical details \[18\]](#))

$R_l / \text{km}$  = cable resistance/km

- ▶ Use copper wiring with a temperature stability of 60/75 °C.
- ▶ To prevent EMC interferences (particularly common-mode interferences) the measures described in EN 60204-1 must be executed. This includes the separate routing of cables of the control circuits (input, start and feedback loop) from other cables for energy transmission or the shielding of cables, for example.
- ▶ Adequate protection must be provided on all output contacts with capacitive and inductive loads.
- ▶ Do not switch low currents using contacts that have been used previously with high currents.
- ▶ When used with converters: Please comply with the information regarding installation and wiring in the documentation of the converter. Use screened cable for the wiring between the PSWZ X1P and the motor. Connect the cable screening on the motor.
- ▶ Protect the measuring circuits according to the conductor cross section.
- ▶ Single-phase motor: Connect terminal L1 directly to motor connection terminal L, and terminal L3 directly to motor connection terminal N. Connect terminal L2 directly to the element that switches the motor on (contactor, converter, etc.). Separate cables with separate insulation should be used for the measuring voltages L1 and L2. The cables should also be physically separate.
- ▶ Three-phase motor: Connect the connection terminals L1, L2 and L3 directly to the motor connection terminals L1, L2 and L3.
- ▶ Do **not** connect the terminals labelled "\*\*\*".

## Preparing for operation

### Connection

Supply voltage	AC	DC
Input circuit	Single-phase motor	Three-phase motor
Three-phase motor = two-phase measurement signal evaluation	/	
Single-phase motor/DC motor = single-phase measurement signal evaluation		
Three-phase motor = single-phase measurement signal evaluation		
Feedback loop	with feedback loop monitoring	without feedback loop monitoring
Contacts from external contactors or bridge		
Semiconductor output		
Y32: Semiconductor output for switch status Y35: Semiconductor output for fault signal		
Semiconductor input		

**Set standstill detection**

- ▶ Turn the potentiometer to the left-hand stop (default setting)
- ▶ Set standstill detection
  - At motor standstill, the LEDs "CH.1 IN" and "CH.2 IN" must light up. If the LEDs do not light in the default setting, turn the potentiometer gradually to the right until the LEDs "CH.1 IN" and "CH.2 IN" light up.
  - If the simultaneity requirement is met, the "OUTPUT" LED will also light up. Safety contacts 13-14 and 23-24 are closed, auxiliary contact 41-42 is open, there is a High signal at the semiconductor output Y32.
  - If the simultaneity requirement is exceeded, the "FAULT" LED will light up. Safety contacts 13-14 and 23-24 are open, auxiliary contact 41-42 is closed, a low signal is present at semiconductor output Y32. Reset the error by a pulse (High- Low- signal) at the reset input.
- ▶ Test standstill detection
  - Close the feedback loop, start up the motor and then switch it off again. As soon as the motor is at standstill, the LEDs "CH.1 IN", "CH.2 IN" and "OUTPUT" light up. Safety contacts 13-14 and 23-24 are closed, auxiliary contact 41-42 is open, there is a High signal at the semiconductor output Y32.

**INFORMATION**

We recommend that after setting the standstill detection, you seal the potentiometer with the label supplied.

**Application example**

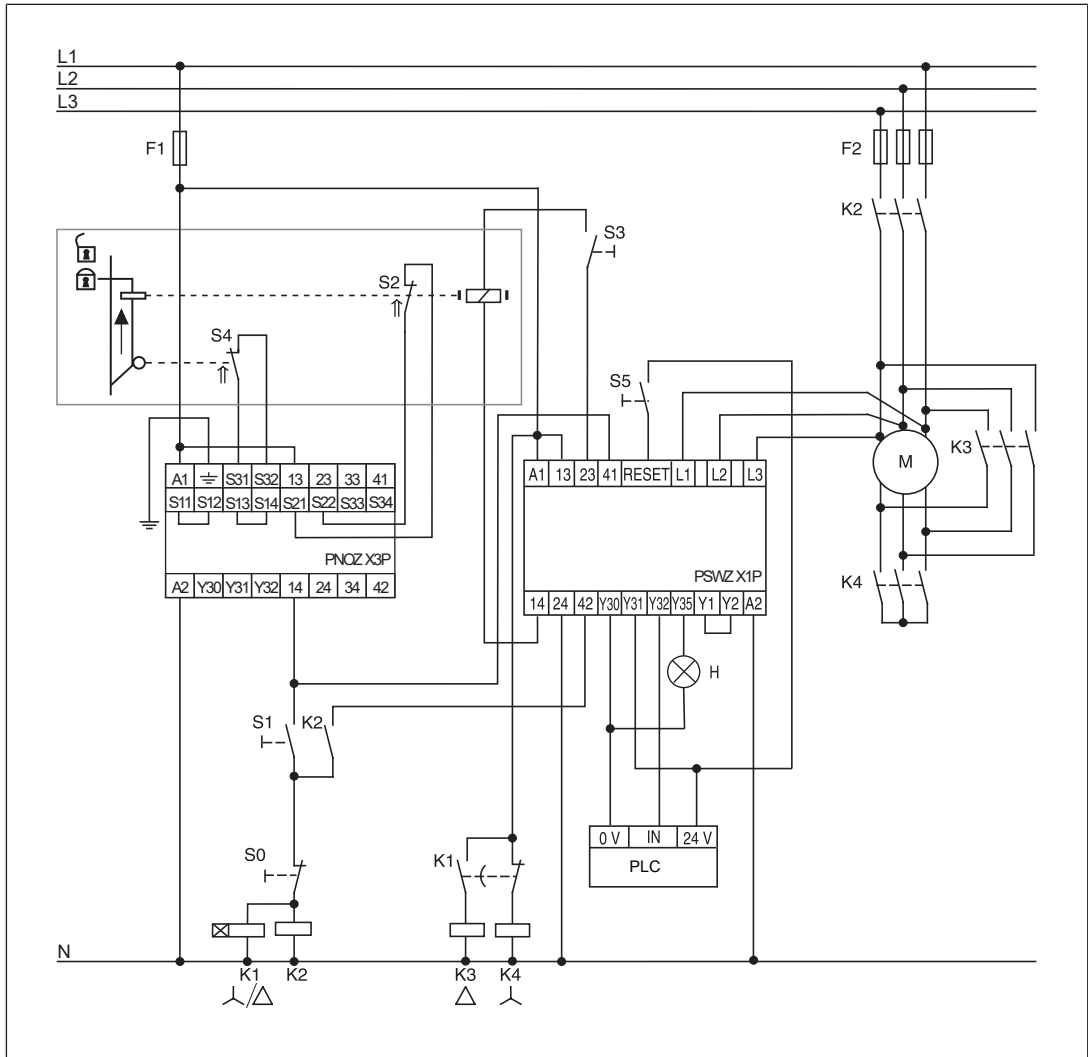

Standstill detection only with closed star contactor contacts

**Legend**

- ▶ S0: Off switch
- ▶ S1: On switch
- ▶ S2/S4: Safety gate switch
- ▶ S3: Release
- ▶ S5: Reset button
- ▶ K1: Star/delta control relay
- ▶ K2: Motor contactor
- ▶ K3: Delta contactor
- ▶ K4: Star contactor
- ▶ H: Fault indicator
- ▶ ↑↑: Operated element
- ▶ : Gate open

▶ : Gate closed

## Operation

When the relay outputs are switched on, the mechanical contact on the relay cannot be tested automatically. Depending on the operational environment, measures to detect the non-opening of switching elements may be required under some circumstances.



### NOTICE

The safety functions should be checked after initial commissioning and each time the plant/machine is changed. The safety functions may only be checked by qualified personnel.



### NOTICE

When used as a safe standstill monitoring, the following test must be performed at least once a week:

- Start up the motor. All LEDs except "POWER" must go out. Safety contacts 13-14 and 23-24 must be open and auxiliary contact 41-42 must be closed.
- Switch the motor off again. The LEDs "CH.1 IN", "CH.2 IN" and "OUTPUT" should not light up / safety contacts 13-14 and 23-24 should not be closed and the auxiliary contact 41-42 open until the motor shaft has come to a standstill.





LEDs indicate the status and errors during operation:

 LED on

**Status indicators**

 **POWER**  
Supply voltage is present.

 **CH.1 IN**  
Channel 1 safety contacts are closed.

 **CH.2 IN**  
Channel 2 safety contacts are closed.

 **OUTPUT**  
Safety contacts are closed and semiconductor output Y32 carries a high signal.

**Fault indicators**

 **FAULT**

Diagnostics: Simultaneity requirement is exceeded or single-channel exceeding and subsequent value falls again below the standstill threshold  $U_{Off}$

- ▶ Remedy: Reset the error by supplying a High signal and then a Low signal at the Reset input.

**Faults – Interference**

- ▶ LED "POWER" does not light: Short circuit or no supply voltage.
- ▶ Contact malfunctions: If the contacts have welded, reactivation will not be possible after the input circuit has opened.
- ▶ When exceeding the simultaneity time the safety contacts 13-14, 23-24 remain open.

**Dimensions in mm**

\* with spring-loaded terminals

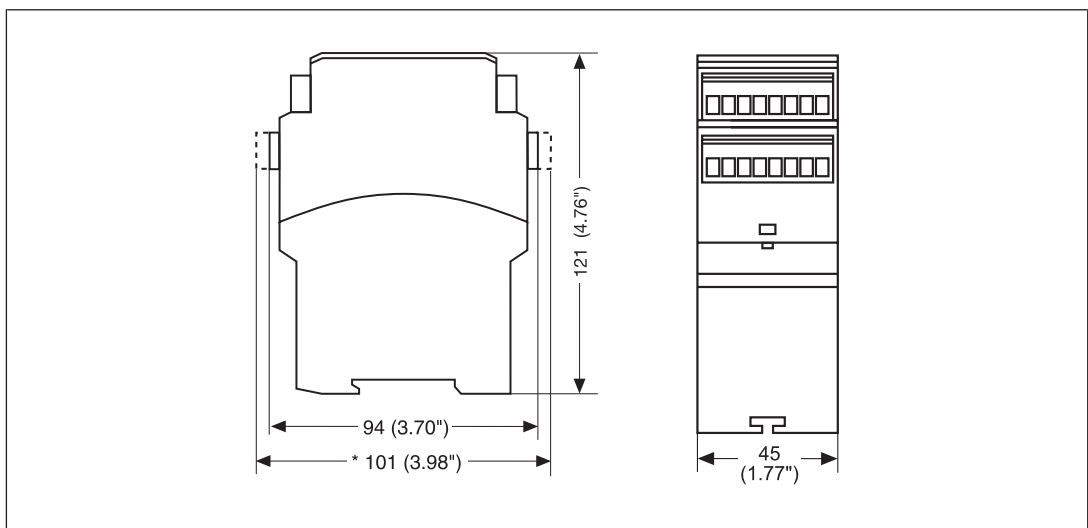

## Technical details

Order no. 777949 – 777950

See below for more order numbers

General	777949	777950
Certifications	CCC, CE, EAC, TÜV, UKCA, cULus Listed	CCC, CE, EAC, TÜV, UKCA, cULus Listed
Electrical data	777949	777950
Supply voltage		
Voltage	24 - 240 V	24 - 240 V
Kind	AC/DC	AC/DC
Voltage tolerance	-15 %/+10 %	-15 %/+10 %
Output of external power supply (AC)	5 VA	5 VA
Output of external power supply (DC)	3 W	3 W
Frequency range AC	50 - 60 Hz	50 - 60 Hz
Residual ripple DC	160 %	160 %
Max. inrush current at UB	10 A	10 A
Duty cycle	100 %	100 %
Measuring circuit	777949	777950
Min. measuring voltage	0,0 V	0,0 V
Max. measuring voltage	690 V	690 V
Measuring voltage in accordance with UL	600 V	600 V
Frequency range	0 - 3 kHz	0 - 3 kHz
input resistance	1.300 kOhm	1.300 kOhm
Switching threshold per channel		
Response value U <sub>on</sub> (adjustable)	20 - 500 mV	120 - 3000 mV
Release value U <sub>off</sub>	2 x U <sub>on</sub>	2 x U <sub>on</sub>
Inputs	777949	777950
Voltage at		
Feedback loop DC	24 V	24 V
Current at		
Feedback loop DC	35 mA	35 mA
Max. inrush current impulse		
Current pulse, feedback loop	0,12 A	0,12 A
Pulse duration, feedback loop	0,1 s	0,1 s
Reset input	777949	777950
Low signal	< 5 V	< 5 V
High signal	> 15 V	> 15 V
Current	20 mA	20 mA

<b>Semiconductor outputs</b>	<b>777949</b>	<b>777950</b>
Quantity	2	2
Voltage	24 V	24 V
Current	50 mA	50 mA
External supply voltage	24 V	24 V
Voltage tolerance	-20 %/+20 %	-20 %/+20 %
Residual current at "0" signal	0,1 mA	0,1 mA
Max. internal voltage drop	4 V	4 V
Conditional rated short circuit current	100 A	100 A
Lowest operating current	0 mA	0 mA
Utilisation category in accordance with EN 60947-1	DC-12	DC-12
<b>Relay outputs</b>	<b>777949</b>	<b>777950</b>
Number of output contacts		
Safety contacts (N/O), instantaneous	2	2
Auxiliary contacts (N/C)	1	1
Max. short circuit current I <sub>K</sub>	1 kA	1 kA
Utilisation category		
in accordance with the standard	EN 60947-4-1	EN 60947-4-1
Utilisation category of safety contacts		
AC1 at	240 V	240 V
Min. current	0,01 A	0,01 A
Max. current	6 A	6 A
Max. power	1500 VA	1500 VA
DC1 at	24 V	24 V
Min. current	0,01 A	0,01 A
Max. current	6 A	6 A
Max. power	150 W	150 W
Utilisation category of auxiliary contacts		
AC1 at	240 V	240 V
Min. current	0,01 A	0,01 A
Max. current	6 A	6 A
Max. power	1500 VA	1500 VA
DC1 at	24 V	24 V
Min. current	0,01 A	0,01 A
Max. current	6 A	6 A
Max. power	150 W	150 W
Utilisation category		
in accordance with the standard	EN 60947-5-1	EN 60947-5-1

<b>Relay outputs</b>	<b>777949</b>	<b>777950</b>
Utilisation category of safety contacts		
AC15 at	<b>230 V</b>	<b>230 V</b>
Max. current	<b>3 A</b>	<b>3 A</b>
DC13 (6 cycles/min) at	<b>24 V</b>	<b>24 V</b>
Max. current	<b>4 A</b>	<b>4 A</b>
Utilisation category of auxiliary contacts		
AC15 at	<b>230 V</b>	<b>230 V</b>
Max. current	<b>3 A</b>	<b>3 A</b>
DC13 (6 cycles/min) at	<b>24 V</b>	<b>24 V</b>
Max. current	<b>4 A</b>	<b>4 A</b>
Utilisation category in accordance with UL		
Voltage with current	<b>240 V AC G. P. 6 A</b>	<b>240 V AC G. P. 6 A</b>
External contact fuse protection, safety contacts		
in accordance with the standard	<b>EN 60947-5-1</b>	<b>EN 60947-5-1</b>
Max. melting integral	<b>66 A<sup>2</sup>s</b>	<b>66 A<sup>2</sup>s</b>
Blow-out fuse, quick	<b>6 A</b>	<b>6 A</b>
Blow-out fuse, slow	<b>4 A</b>	<b>4 A</b>
Blow-out fuse, gG	<b>6 A</b>	<b>6 A</b>
Circuit breaker 24V AC/DC, characteristic B/C	<b>4 A</b>	<b>4 A</b>
External contact fuse protection, auxiliary contacts		
Max. melting integral	<b>66 A<sup>2</sup>s</b>	<b>66 A<sup>2</sup>s</b>
Blow-out fuse, quick	<b>6 A</b>	<b>6 A</b>
Blow-out fuse, slow	<b>4 A</b>	<b>4 A</b>
Blow-out fuse, gG	<b>6 A</b>	<b>6 A</b>
Circuit breaker, 24 V AC/DC, characteristic B/C	<b>4 A</b>	<b>4 A</b>
Conventional thermal current	<b>6 A</b>	<b>6 A</b>
Contact material	<b>AgCuNi + 0,2 µm Au</b>	<b>AgCuNi + 0,2 µm Au</b>
<b>Conventional thermal current while loading several contacts</b>	<b>777949</b>	<b>777950</b>
I <sub>th</sub> per contact at UB DC; AC1: 240 V, DC1: 24 V		
Conv. therm. current with 1 contact	<b>6 A</b>	<b>6 A</b>
Conv. therm. current with 2 contacts	<b>4 A</b>	<b>4 A</b>
<b>Times</b>	<b>777949</b>	<b>777950</b>
Max. switch-on delay		
after motor standstill max.	<b>1.500 ms</b>	<b>1.500 ms</b>
after power on max.	<b>2.200 ms</b>	<b>2.200 ms</b>

<b>Times</b>	<b>777949</b>	<b>777950</b>
Delay-on de-energisation		
after motor on max.	<b>170 ms</b>	<b>170 ms</b>
Recovery time at max. switching frequency 1/s		
after motor on	<b>2.200 ms</b>	<b>2.200 ms</b>
Supply interruption before de-energisation	<b>20 ms</b>	<b>20 ms</b>
Simultaneity, channel 1 and 2 max.	<b>7 s</b>	<b>7 s</b>
<b>Environmental data</b>	<b>777949</b>	<b>777950</b>
Climatic suitability	<b>EN 60068-2-78</b>	<b>EN 60068-2-78</b>
Ambient temperature		
Temperature range	<b>-10 - 55 °C</b>	<b>-10 - 55 °C</b>
Storage temperature		
Temperature range	<b>-40 - 85 °C</b>	<b>-40 - 85 °C</b>
Climatic suitability		
Humidity	<b>93 % r. h. at 40 °C</b>	<b>93 % r. h. at 40 °C</b>
Condensation during operation	<b>Not permitted</b>	<b>Not permitted</b>
EMC	<b>EN 60947-5-1, EN 61000-6-2, EN 61000-6-4, EN 61326-3-1</b>	<b>EN 60947-5-1, EN 61000-6-2, EN 61000-6-4, EN 61326-3-1</b>
Vibration		
in accordance with the standard	<b>EN 60068-2-6</b>	<b>EN 60068-2-6</b>
Frequency	<b>10 - 55 Hz</b>	<b>10 - 55 Hz</b>
Amplitude	<b>0,35 mm</b>	<b>0,35 mm</b>
Airgap creepage		
in accordance with the standard	<b>EN 60947-1</b>	<b>EN 60947-1</b>
Overvoltage category	<b>III / II</b>	<b>III / II</b>
Pollution degree	<b>2</b>	<b>2</b>
Rated insulation voltage	<b>690 V</b>	<b>690 V</b>
Rated impulse withstand voltage	<b>6 kV</b>	<b>6 kV</b>
Protection type		
Housing	<b>IP40</b>	<b>IP40</b>
Terminals	<b>IP20</b>	<b>IP20</b>
Mounting area (e.g. control cabinet)	<b>IP54</b>	<b>IP54</b>
<b>Mechanical data</b>	<b>777949</b>	<b>777950</b>
Mounting position	<b>Any</b>	<b>Any</b>
Mechanical life	<b>10,000,000 cycles</b>	<b>10,000,000 cycles</b>
Material		
Bottom	<b>PPO UL 94 V1</b>	<b>PPO UL 94 V1</b>
Front	<b>ABS UL 94 V0</b>	<b>ABS UL 94 V0</b>
Top	<b>PPO UL 94 V1</b>	<b>PPO UL 94 V1</b>
Connection type	<b>Screw terminal</b>	<b>Screw terminal</b>
Mounting type	<b>plug-in</b>	<b>plug-in</b>

<b>Mechanical data</b>	<b>777949</b>	<b>777950</b>
Conductor cross section with screw terminals		
1 core flexible	<b>0,25 - 2,5 mm<sup>2</sup>, 24 - 14 AWG</b>	<b>0,25 - 2,5 mm<sup>2</sup>, 24 - 14 AWG</b>
2 core with the same cross section, flexible with crimp connectors, no plastic sleeve	<b>0,25 - 1 mm<sup>2</sup>, 24 - 16 AWG</b>	<b>0,25 - 1 mm<sup>2</sup>, 24 - 16 AWG</b>
2 core with the same cross section, flexible without crimp connectors or with TWIN crimp connectors	<b>0,5 - 1,5 mm<sup>2</sup>, 24 - 16 AWG</b>	<b>0,5 - 1,5 mm<sup>2</sup>, 24 - 16 AWG</b>
Torque setting with screw terminals	<b>0,5 Nm</b>	<b>0,5 Nm</b>
Stripping length with screw terminals	<b>8 mm</b>	<b>8 mm</b>
Dimensions		
Height	<b>94 mm</b>	<b>94 mm</b>
Width	<b>45 mm</b>	<b>45 mm</b>
Depth	<b>121 mm</b>	<b>121 mm</b>
Weight	<b>325 g</b>	<b>325 g</b>

Where standards are undated, the 2022-09 latest editions shall apply.

**Order no. 777951 – 777959**

See below for more order numbers

<b>General</b>	<b>777951</b>	<b>777959</b>
Certifications	<b>CCC, CE, EAC, TÜV, UKCA, cULus Listed</b>	<b>CCC, CE, EAC, TÜV, UKCA, cULus Listed</b>
<b>Electrical data</b>	<b>777951</b>	<b>777959</b>
Supply voltage		
Voltage	<b>24 - 240 V</b>	<b>24 - 240 V</b>
Kind	<b>AC/DC</b>	<b>AC/DC</b>
Voltage tolerance	<b>-15 %/+10 %</b>	<b>-15 %/+10 %</b>
Output of external power supply (AC)	<b>5 VA</b>	<b>5 VA</b>
Output of external power supply (DC)	<b>3 W</b>	<b>3 W</b>
Frequency range AC	<b>50 - 60 Hz</b>	<b>50 - 60 Hz</b>
Residual ripple DC	<b>160 %</b>	<b>160 %</b>
Max. inrush current at UB	<b>10 A</b>	<b>10 A</b>
Duty cycle	<b>100 %</b>	<b>100 %</b>
<b>Measuring circuit</b>	<b>777951</b>	<b>777959</b>
Min. measuring voltage	<b>0,0 V</b>	<b>0,0 V</b>
Max. measuring voltage	<b>690 V</b>	<b>690 V</b>
Measuring voltage in accordance with UL	<b>600 V</b>	<b>600 V</b>
Frequency range	<b>0 - 3 kHz</b>	<b>0 - 3 kHz</b>

<b>Measuring circuit</b>		
	<b>777951</b>	<b>777959</b>
input resistance	<b>1.300 kOhm</b>	<b>1.300 kOhm</b>
Switching threshold per channel		
Response value U <sub>on</sub> (adjustable)	<b>7,5 - 500 mV</b>	<b>20 - 500 mV</b>
Release value U <sub>off</sub>	<b>2 x U<sub>on</sub></b>	<b>2 x U<sub>on</sub></b>
<b>Inputs</b>		
	<b>777951</b>	<b>777959</b>
Voltage at		
Feedback loop DC	<b>24 V</b>	<b>24 V</b>
Current at		
Feedback loop DC	<b>35 mA</b>	<b>35 mA</b>
Max. inrush current impulse		
Current pulse, feedback loop	<b>0,12 A</b>	<b>0,12 A</b>
Pulse duration, feedback loop	<b>0,1 s</b>	<b>0,1 s</b>
<b>Reset input</b>		
	<b>777951</b>	<b>777959</b>
Low signal	<b>&lt; 5 V</b>	<b>&lt; 5 V</b>
High signal	<b>&gt; 15 V</b>	<b>&gt; 15 V</b>
Current	<b>20 mA</b>	<b>20 mA</b>
<b>Semiconductor outputs</b>		
	<b>777951</b>	<b>777959</b>
Quantity	<b>2</b>	<b>2</b>
Voltage	<b>24 V</b>	<b>24 V</b>
Current	<b>50 mA</b>	<b>50 mA</b>
External supply voltage	<b>24 V</b>	<b>24 V</b>
Voltage tolerance	<b>-20 %/+20 %</b>	<b>-20 %/+20 %</b>
Residual current at "0" signal	<b>0,1 mA</b>	<b>0,1 mA</b>
Max. internal voltage drop	<b>4 V</b>	<b>4 V</b>
Conditional rated short circuit current	<b>100 A</b>	<b>100 A</b>
Lowest operating current	<b>0 mA</b>	<b>0 mA</b>
Utilisation category in accordance with EN 60947-1	<b>DC-12</b>	<b>DC-12</b>
<b>Relay outputs</b>		
	<b>777951</b>	<b>777959</b>
Number of output contacts		
Safety contacts (N/O), instantaneous	<b>2</b>	<b>2</b>
Auxiliary contacts (N/C)	<b>1</b>	<b>1</b>
Max. short circuit current I <sub>K</sub>	<b>1 kA</b>	<b>1 kA</b>
Utilisation category		
in accordance with the standard	<b>EN 60947-4-1</b>	<b>EN 60947-4-1</b>

<b>Relay outputs</b>	<b>777951</b>	<b>777959</b>
Utilisation category of safety contacts		
AC1 at	<b>240 V</b>	<b>240 V</b>
Min. current	<b>0,01 A</b>	<b>0,01 A</b>
Max. current	<b>6 A</b>	<b>6 A</b>
Max. power	<b>1500 VA</b>	<b>1500 VA</b>
DC1 at	<b>24 V</b>	<b>24 V</b>
Min. current	<b>0,01 A</b>	<b>0,01 A</b>
Max. current	<b>6 A</b>	<b>6 A</b>
Max. power	<b>150 W</b>	<b>150 W</b>
Utilisation category of auxiliary contacts		
AC1 at	<b>240 V</b>	<b>240 V</b>
Min. current	<b>0,01 A</b>	<b>0,01 A</b>
Max. current	<b>6 A</b>	<b>6 A</b>
Max. power	<b>1500 VA</b>	<b>1500 VA</b>
DC1 at	<b>24 V</b>	<b>24 V</b>
Min. current	<b>0,01 A</b>	<b>0,01 A</b>
Max. current	<b>6 A</b>	<b>6 A</b>
Max. power	<b>150 W</b>	<b>150 W</b>
Utilisation category		
in accordance with the standard	<b>EN 60947-5-1</b>	<b>EN 60947-5-1</b>
Utilisation category of safety contacts		
AC15 at	<b>230 V</b>	<b>230 V</b>
Max. current	<b>3 A</b>	<b>3 A</b>
DC13 (6 cycles/min) at	<b>24 V</b>	<b>24 V</b>
Max. current	<b>4 A</b>	<b>4 A</b>
Utilisation category of auxiliary contacts		
AC15 at	<b>230 V</b>	<b>230 V</b>
Max. current	<b>3 A</b>	<b>3 A</b>
DC13 (6 cycles/min) at	<b>24 V</b>	<b>24 V</b>
Max. current	<b>4 A</b>	<b>4 A</b>
Utilisation category in accordance with UL		
Voltage	<b>240 V AC G. P.</b>	<b>240 V AC G. P.</b>
with current	<b>6 A</b>	<b>6 A</b>
External contact fuse protection, safety contacts		
in accordance with the standard	<b>EN 60947-5-1</b>	<b>EN 60947-5-1</b>
Max. melting integral	<b>66 A<sup>2</sup>s</b>	<b>66 A<sup>2</sup>s</b>
Blow-out fuse, quick	<b>6 A</b>	<b>6 A</b>
Blow-out fuse, slow	<b>4 A</b>	<b>4 A</b>
Blow-out fuse, gG	<b>6 A</b>	<b>6 A</b>
Circuit breaker 24V AC/DC, characteristic B/C	<b>4 A</b>	<b>4 A</b>



<b>Relay outputs</b>	<b>777951</b>	<b>777959</b>
External contact fuse protection, auxiliary contacts		
Max. melting integral	<b>66 A<sup>2</sup>s</b>	<b>66 A<sup>2</sup>s</b>
Blow-out fuse, quick	<b>6 A</b>	<b>6 A</b>
Blow-out fuse, slow	<b>4 A</b>	<b>4 A</b>
Blow-out fuse, gG	<b>6 A</b>	<b>6 A</b>
Circuit breaker, 24 V AC/DC, characteristic B/C	<b>4 A</b>	<b>4 A</b>
Conventional thermal current	<b>6 A</b>	<b>6 A</b>
Contact material	<b>AgCuNi + 0,2 µm Au</b>	<b>AgCuNi + 0,2 µm Au</b>
<b>Conventional thermal current while loading several contacts</b>	<b>777951</b>	<b>777959</b>
I <sub>th</sub> per contact at UB DC; AC1: 240 V, DC1: 24 V		
Conv. therm. current with 1 contact	<b>6 A</b>	<b>6 A</b>
Conv. therm. current with 2 contacts	<b>4 A</b>	<b>4 A</b>
<b>Times</b>	<b>777951</b>	<b>777959</b>
Max. switch-on delay		
after motor standstill max.	<b>1.500 ms</b>	<b>1.500 ms</b>
after power on max.	<b>2.200 ms</b>	<b>2.200 ms</b>
Delay-on de-energisation		
after motor on max.	<b>170 ms</b>	<b>170 ms</b>
Recovery time at max. switching frequency 1/s		
after motor on	<b>2.200 ms</b>	<b>2.200 ms</b>
Supply interruption before de-energisation	<b>20 ms</b>	<b>20 ms</b>
Simultaneity, channel 1 and 2 max.	<b>7 s</b>	<b>7 s</b>
<b>Environmental data</b>	<b>777951</b>	<b>777959</b>
Climatic suitability	<b>EN 60068-2-78</b>	<b>EN 60068-2-78</b>
Ambient temperature		
Temperature range	<b>-10 - 55 °C</b>	<b>-10 - 55 °C</b>
Storage temperature		
Temperature range	<b>-40 - 85 °C</b>	<b>-40 - 85 °C</b>
Climatic suitability		
Humidity	<b>93 % r. h. at 40 °C</b>	<b>93 % r. h. at 40 °C</b>
Condensation during operation	<b>Not permitted</b>	<b>Not permitted</b>
EMC	<b>EN 60947-5-1, EN 61000-6-2, EN 61000-6-4, EN 61326-3-1</b>	<b>EN 60947-5-1, EN 61000-6-2, EN 61000-6-4, EN 61326-3-1</b>
Vibration		
in accordance with the standard	<b>EN 60068-2-6</b>	<b>EN 60068-2-6</b>
Frequency	<b>10 - 55 Hz</b>	<b>10 - 55 Hz</b>
Amplitude	<b>0,35 mm</b>	<b>0,35 mm</b>

<b>Environmental data</b>	<b>777951</b>	<b>777959</b>
Airgap creepage		
in accordance with the standard	<b>EN 60947-1</b>	<b>EN 60947-1</b>
Overvoltage category	<b>III / II</b>	<b>III / II</b>
Pollution degree	<b>2</b>	<b>2</b>
Rated insulation voltage	<b>690 V</b>	<b>690 V</b>
Rated impulse withstand voltage	<b>6 kV</b>	<b>6 kV</b>
Protection type		
Housing	<b>IP40</b>	<b>IP40</b>
Terminals	<b>IP20</b>	<b>IP20</b>
Mounting area (e.g. control cabinet)	<b>IP54</b>	<b>IP54</b>
<b>Mechanical data</b>	<b>777951</b>	<b>777959</b>
Mounting position	<b>Any</b>	<b>Any</b>
Mechanical life	<b>10,000,000 cycles</b>	<b>10,000,000 cycles</b>
Material		
Bottom	<b>PPO UL 94 V1</b>	<b>PPO UL 94 V1</b>
Front	<b>ABS UL 94 V0</b>	<b>ABS UL 94 V0</b>
Top	<b>PPO UL 94 V1</b>	<b>PPO UL 94 V1</b>
Connection type	<b>Screw terminal</b>	<b>Screw terminal</b>
Mounting type	<b>plug-in</b>	<b>plug-in</b>
Conductor cross section with screw terminals		
1 core flexible	<b>0,25 - 2,5 mm<sup>2</sup>, 24 - 14 AWG</b>	<b>0,25 - 2,5 mm<sup>2</sup>, 24 - 14 AWG</b>
2 core with the same cross section, flexible with crimp connectors, no plastic sleeve	<b>0,25 - 1 mm<sup>2</sup>, 24 - 16 AWG</b>	<b>0,25 - 1 mm<sup>2</sup>, 24 - 16 AWG</b>
2 core with the same cross section, flexible without crimp connectors or with TWIN crimp connectors	<b>0,5 - 1,5 mm<sup>2</sup>, 24 - 16 AWG</b>	<b>0,5 - 1,5 mm<sup>2</sup>, 24 - 16 AWG</b>
Torque setting with screw terminals	<b>0,5 Nm</b>	<b>0,5 Nm</b>
Stripping length with screw terminals	<b>8 mm</b>	<b>8 mm</b>
Dimensions		
Height	<b>94 mm</b>	<b>94 mm</b>
Width	<b>45 mm</b>	<b>45 mm</b>
Depth	<b>121 mm</b>	<b>121 mm</b>
Weight	<b>325 g</b>	<b>325 g</b>

Where standards are undated, the 2022-09 latest editions shall apply.

## Order no. 787949 – 787951

<b>General</b>	<b>787949</b>	<b>787950</b>	<b>787951</b>
Certifications	CCC, CE, EAC, TÜV, UKCA, cULus Listed	CCC, CE, EAC, TÜV, UKCA, cULus Listed	CCC, CE, EAC, TÜV, UKCA, cULus Listed
<b>Electrical data</b>	<b>787949</b>	<b>787950</b>	<b>787951</b>
Supply voltage			
Voltage	24 - 240 V	24 - 240 V	24 - 240 V
Kind	AC/DC	AC/DC	AC/DC
Voltage tolerance	-15 %/+10 %	-15 %/+10 %	-15 %/+10 %
Output of external power supply (AC)	5 VA	5 VA	5 VA
Output of external power supply (DC)	3 W	3 W	3 W
Frequency range AC	50 - 60 Hz	50 - 60 Hz	50 - 60 Hz
Residual ripple DC	160 %	160 %	160 %
Max. inrush current at UB	10 A	10 A	10 A
Duty cycle	100 %	100 %	100 %
<b>Measuring circuit</b>	<b>787949</b>	<b>787950</b>	<b>787951</b>
Min. measuring voltage	0,0 V	0,0 V	0,0 V
Max. measuring voltage	690 V	690 V	690 V
Measuring voltage in accordance with UL	600 V	600 V	600 V
Frequency range	0 - 3 kHz	0 - 3 kHz	0 - 3 kHz
input resistance	1.300 kOhm	1.300 kOhm	1.300 kOhm
Switching threshold per channel			
Response value U <sub>on</sub> (adjustable)	20 - 500 mV	120 - 3000 mV	7,5 - 500 mV
Release value U <sub>off</sub>	2 x U <sub>on</sub>	2 x U <sub>on</sub>	2 x U <sub>on</sub>
<b>Inputs</b>	<b>787949</b>	<b>787950</b>	<b>787951</b>
Voltage at			
Feedback loop DC	24 V	24 V	24 V
Current at			
Feedback loop DC	35 mA	35 mA	35 mA
Max. inrush current impulse			
Current pulse, feedback loop	0,12 A	0,12 A	0,12 A
Pulse duration, feedback loop	0,1 s	0,1 s	0,1 s
<b>Reset input</b>	<b>787949</b>	<b>787950</b>	<b>787951</b>
Low signal	< 5 V	< 5 V	< 5 V
High signal	> 15 V	> 15 V	> 15 V
Current	20 mA	20 mA	20 mA
<b>Semiconductor outputs</b>	<b>787949</b>	<b>787950</b>	<b>787951</b>
Quantity	2	2	2

<b>Semiconductor outputs</b>	<b>787949</b>	<b>787950</b>	<b>787951</b>
Voltage	<b>24 V</b>	<b>24 V</b>	<b>24 V</b>
Current	<b>50 mA</b>	<b>50 mA</b>	<b>50 mA</b>
External supply voltage	<b>24 V</b>	<b>24 V</b>	<b>24 V</b>
Voltage tolerance	<b>-20 %/+20 %</b>	<b>-20 %/+20 %</b>	<b>-20 %/+20 %</b>
Residual current at "0" signal	<b>0,1 mA</b>	<b>0,1 mA</b>	<b>0,1 mA</b>
Max. internal voltage drop	<b>4 V</b>	<b>4 V</b>	<b>4 V</b>
Conditional rated short circuit current	<b>100 A</b>	<b>100 A</b>	<b>100 A</b>
Lowest operating current	<b>0 mA</b>	<b>0 mA</b>	<b>0 mA</b>
Utilisation category in accordance with EN 60947-1	<b>DC-12</b>	<b>DC-12</b>	<b>DC-12</b>
<b>Relay outputs</b>	<b>787949</b>	<b>787950</b>	<b>787951</b>
Number of output contacts			
Safety contacts (N/O), instantaneous	<b>2</b>	<b>2</b>	<b>2</b>
Auxiliary contacts (N/C)	<b>1</b>	<b>1</b>	<b>1</b>
Max. short circuit current IK	<b>1 kA</b>	<b>1 kA</b>	<b>1 kA</b>
Utilisation category in accordance with the standard	<b>EN 60947-4-1</b>	<b>EN 60947-4-1</b>	<b>EN 60947-4-1</b>
Utilisation category of safety contacts			
AC1 at	<b>240 V</b>	<b>240 V</b>	<b>240 V</b>
Min. current	<b>0,01 A</b>	<b>0,01 A</b>	<b>0,01 A</b>
Max. current	<b>6 A</b>	<b>6 A</b>	<b>6 A</b>
Max. power	<b>1500 VA</b>	<b>1500 VA</b>	<b>1500 VA</b>
DC1 at	<b>24 V</b>	<b>24 V</b>	<b>24 V</b>
Min. current	<b>0,01 A</b>	<b>0,01 A</b>	<b>0,01 A</b>
Max. current	<b>6 A</b>	<b>6 A</b>	<b>6 A</b>
Max. power	<b>150 W</b>	<b>150 W</b>	<b>150 W</b>
Utilisation category of auxiliary contacts			
AC1 at	<b>240 V</b>	<b>240 V</b>	<b>240 V</b>
Min. current	<b>0,01 A</b>	<b>0,01 A</b>	<b>0,01 A</b>
Max. current	<b>6 A</b>	<b>6 A</b>	<b>6 A</b>
Max. power	<b>1500 VA</b>	<b>1500 VA</b>	<b>1500 VA</b>
DC1 at	<b>24 V</b>	<b>24 V</b>	<b>24 V</b>
Min. current	<b>0,01 A</b>	<b>0,01 A</b>	<b>0,01 A</b>
Max. current	<b>6 A</b>	<b>6 A</b>	<b>6 A</b>
Max. power	<b>150 W</b>	<b>150 W</b>	<b>150 W</b>
Utilisation category in accordance with the standard	<b>EN 60947-5-1</b>	<b>EN 60947-5-1</b>	<b>EN 60947-5-1</b>

<b>Relay outputs</b>	<b>787949</b>	<b>787950</b>	<b>787951</b>
Utilisation category of safety contacts			
AC15 at	<b>230 V</b>	<b>230 V</b>	<b>230 V</b>
Max. current	<b>3 A</b>	<b>3 A</b>	<b>3 A</b>
DC13 (6 cycles/min) at	<b>24 V</b>	<b>24 V</b>	<b>24 V</b>
Max. current	<b>4 A</b>	<b>4 A</b>	<b>4 A</b>
Utilisation category of auxiliary contacts			
AC15 at	<b>230 V</b>	<b>230 V</b>	<b>230 V</b>
Max. current	<b>3 A</b>	<b>3 A</b>	<b>3 A</b>
DC13 (6 cycles/min) at	<b>24 V</b>	<b>24 V</b>	<b>24 V</b>
Max. current	<b>4 A</b>	<b>4 A</b>	<b>4 A</b>
Utilisation category in accordance with UL			
Voltage with current	<b>240 V AC G. P. 6 A</b>	<b>240 V AC G. P. 6 A</b>	<b>240 V AC G. P. 6 A</b>
External contact fuse protection, safety contacts			
in accordance with the standard	<b>EN 60947-5-1</b>	<b>EN 60947-5-1</b>	<b>EN 60947-5-1</b>
Max. melting integral	<b>66 A<sup>2</sup>s</b>	<b>66 A<sup>2</sup>s</b>	<b>66 A<sup>2</sup>s</b>
Blow-out fuse, quick	<b>6 A</b>	<b>6 A</b>	<b>6 A</b>
Blow-out fuse, slow	<b>4 A</b>	<b>4 A</b>	<b>4 A</b>
Blow-out fuse, gG	<b>6 A</b>	<b>6 A</b>	<b>6 A</b>
Circuit breaker 24V AC/DC, characteristic B/C	<b>4 A</b>	<b>4 A</b>	<b>4 A</b>
External contact fuse protection, auxiliary contacts			
Max. melting integral	<b>66 A<sup>2</sup>s</b>	<b>66 A<sup>2</sup>s</b>	<b>66 A<sup>2</sup>s</b>
Blow-out fuse, quick	<b>6 A</b>	<b>6 A</b>	<b>6 A</b>
Blow-out fuse, slow	<b>4 A</b>	<b>4 A</b>	<b>4 A</b>
Blow-out fuse, gG	<b>6 A</b>	<b>6 A</b>	<b>6 A</b>
Circuit breaker, 24 V AC/DC, characteristic B/C	<b>4 A</b>	<b>4 A</b>	<b>4 A</b>
Conventional thermal current	<b>6 A</b>	<b>6 A</b>	<b>6 A</b>
Contact material	<b>AgCuNi + 0,2 µm Au</b>	<b>AgCuNi + 0,2 µm Au</b>	<b>AgCuNi + 0,2 µm Au</b>
<b>Conventional thermal current while loading several contacts</b>	<b>787949</b>	<b>787950</b>	<b>787951</b>
I <sub>th</sub> per contact at UB DC; AC1: 240 V, DC1: 24 V			
Conv. therm. current with 1 contact	<b>6 A</b>	<b>6 A</b>	<b>6 A</b>
Conv. therm. current with 2 contacts	<b>4 A</b>	<b>4 A</b>	<b>4 A</b>

<b>Times</b>	<b>787949</b>	<b>787950</b>	<b>787951</b>
Max. switch-on delay			
after motor standstill max.	<b>1.500 ms</b>	<b>1.500 ms</b>	<b>1.500 ms</b>
after power on max.	<b>2.200 ms</b>	<b>2.200 ms</b>	<b>2.200 ms</b>
Delay-on de-energisation			
after motor on max.	<b>170 ms</b>	<b>170 ms</b>	<b>170 ms</b>
Recovery time at max. switching frequency 1/s			
after motor on	<b>2.200 ms</b>	<b>2.200 ms</b>	<b>2.200 ms</b>
Supply interruption before de-energisation	<b>20 ms</b>	<b>20 ms</b>	<b>20 ms</b>
Simultaneity, channel 1 and 2 max.	<b>7 s</b>	<b>7 s</b>	<b>7 s</b>
<b>Environmental data</b>	<b>787949</b>	<b>787950</b>	<b>787951</b>
Climatic suitability	<b>EN 60068-2-78</b>	<b>EN 60068-2-78</b>	<b>EN 60068-2-78</b>
Ambient temperature			
Temperature range	<b>-10 - 55 °C</b>	<b>-10 - 55 °C</b>	<b>-10 - 55 °C</b>
Storage temperature			
Temperature range	<b>-40 - 85 °C</b>	<b>-40 - 85 °C</b>	<b>-40 - 85 °C</b>
Climatic suitability			
Humidity	<b>93 % r. h. at 40 °C</b>	<b>93 % r. h. at 40 °C</b>	<b>93 % r. h. at 40 °C</b>
Condensation during operation	<b>Not permitted</b>	<b>Not permitted</b>	<b>Not permitted</b>
EMC	<b>EN 60947-5-1, EN 61000-6-2, EN 61000-6-4, EN 61326-3-1</b>	<b>EN 60947-5-1, EN 61000-6-2, EN 61000-6-4, EN 61326-3-1</b>	<b>EN 60947-5-1, EN 61000-6-2, EN 61000-6-4, EN 61326-3-1</b>
Vibration			
in accordance with the standard	<b>EN 60068-2-6</b>	<b>EN 60068-2-6</b>	<b>EN 60068-2-6</b>
Frequency	<b>10 - 55 Hz</b>	<b>10 - 55 Hz</b>	<b>10 - 55 Hz</b>
Amplitude	<b>0,35 mm</b>	<b>0,35 mm</b>	<b>0,35 mm</b>
Airgap creepage			
in accordance with the standard	<b>EN 60947-1</b>	<b>EN 60947-1</b>	<b>EN 60947-1</b>
Overvoltage category	<b>III / II</b>	<b>III / II</b>	<b>III / II</b>
Pollution degree	<b>2</b>	<b>2</b>	<b>2</b>
Rated insulation voltage	<b>690 V</b>	<b>690 V</b>	<b>690 V</b>
Rated impulse withstand voltage	<b>6 kV</b>	<b>6 kV</b>	<b>6 kV</b>
Protection type			
Housing	<b>IP40</b>	<b>IP40</b>	<b>IP40</b>
Terminals	<b>IP20</b>	<b>IP20</b>	<b>IP20</b>
Mounting area (e.g. control cabinet)	<b>IP54</b>	<b>IP54</b>	<b>IP54</b>
<b>Mechanical data</b>	<b>787949</b>	<b>787950</b>	<b>787951</b>
Mounting position	<b>Any</b>	<b>Any</b>	<b>Any</b>
Mechanical life	<b>10,000,000 cycles</b>	<b>10,000,000 cycles</b>	<b>10,000,000 cycles</b>

<b>Mechanical data</b>	<b>787949</b>	<b>787950</b>	<b>787951</b>
Material			
Bottom	<b>PPO UL 94 V1</b>	<b>PPO UL 94 V1</b>	<b>PPO UL 94 V1</b>
Front	<b>ABS UL 94 V0</b>	<b>ABS UL 94 V0</b>	<b>ABS UL 94 V0</b>
Top	<b>PPO UL 94 V1</b>	<b>PPO UL 94 V1</b>	<b>PPO UL 94 V1</b>
Connection type	<b>Spring-loaded terminal</b>	<b>Spring-loaded terminal</b>	<b>Spring-loaded terminal</b>
Mounting type	<b>plug-in</b>	<b>plug-in</b>	<b>plug-in</b>
Conductor cross section with spring-loaded terminals: Flexible with/without crimp connector	<b>0,2 - 1,5 mm<sup>2</sup>, 24 - 16 AWG</b>	<b>0,2 - 1,5 mm<sup>2</sup>, 24 - 16 AWG</b>	<b>0,2 - 1,5 mm<sup>2</sup>, 24 - 16 AWG</b>
Spring-loaded terminals: Terminal points per connection	<b>2</b>	<b>2</b>	<b>2</b>
Stripping length with spring-loaded terminals	<b>8 mm</b>	<b>8 mm</b>	<b>8 mm</b>
Dimensions			
Height	<b>101 mm</b>	<b>101 mm</b>	<b>101 mm</b>
Width	<b>45 mm</b>	<b>45 mm</b>	<b>45 mm</b>
Depth	<b>121 mm</b>	<b>121 mm</b>	<b>121 mm</b>
Weight	<b>325 g</b>	<b>325 g</b>	<b>325 g</b>

Where standards are undated, the 2022-09 latest editions shall apply.

**Safety characteristic data**



**NOTICE**

You must comply with the safety characteristic data in order to achieve the required safety level for your plant/machine.

Operating mode	EN ISO 13849-1: 2015	EN ISO 13849-1: 2015	EN IEC 62061 SIL CL/ maximum SIL	EN IEC 62061 PFH <sub>D</sub> [1/h]	EN/IEC 61511 SIL	EN/IEC 61511 PFD	EN ISO 13849-1: 2015 T <sub>M</sub> [year]
–	PL e	Cat. 4	SIL 3	6,23E-09	SIL 3	6,47E-05	20

Explanatory notes for the safety-related characteristic data:

- ▶ Safety characteristic data in accordance with EN IEC 62061 and EN/IEC 61511 was calculated based on EN/IEC 61508.
- ▶ T<sub>M</sub> is the maximum mission time in accordance with EN ISO 13849-1. The value also applies as the retest interval in accordance with EN/IEC 61508-6 and EN/IEC 61511 and as the proof test interval and mission time in accordance with EN IEC 62061.

All the units used within a safety function must be considered when calculating the safety characteristic data.



**INFORMATION**

A safety function's SIL/PL values are **not** identical to the SIL/PL values of the units that are used and may be different. We recommend that you use the PAScal software tool to calculate the safety function's SIL/PL values.



### Supplementary data



**CAUTION!**

It is essential to consider the relay's service life graphs. The relay outputs' safety-related characteristic data is only valid if the values in the service life graphs are met.

The PFH value depends on the switch frequency and the load of the relay output. If the service life graphs are not accessible, the stated PFH value can be used irrespective of the switch frequency and the load, as the PFH value already considers the relay's B10d value as well as the failure rates of the other components.

**Service life graph**

The service life graphs indicate the number of cycles from which failures due to wear must be expected. The wear is mainly caused by the electrical load; the mechanical load is negligible.

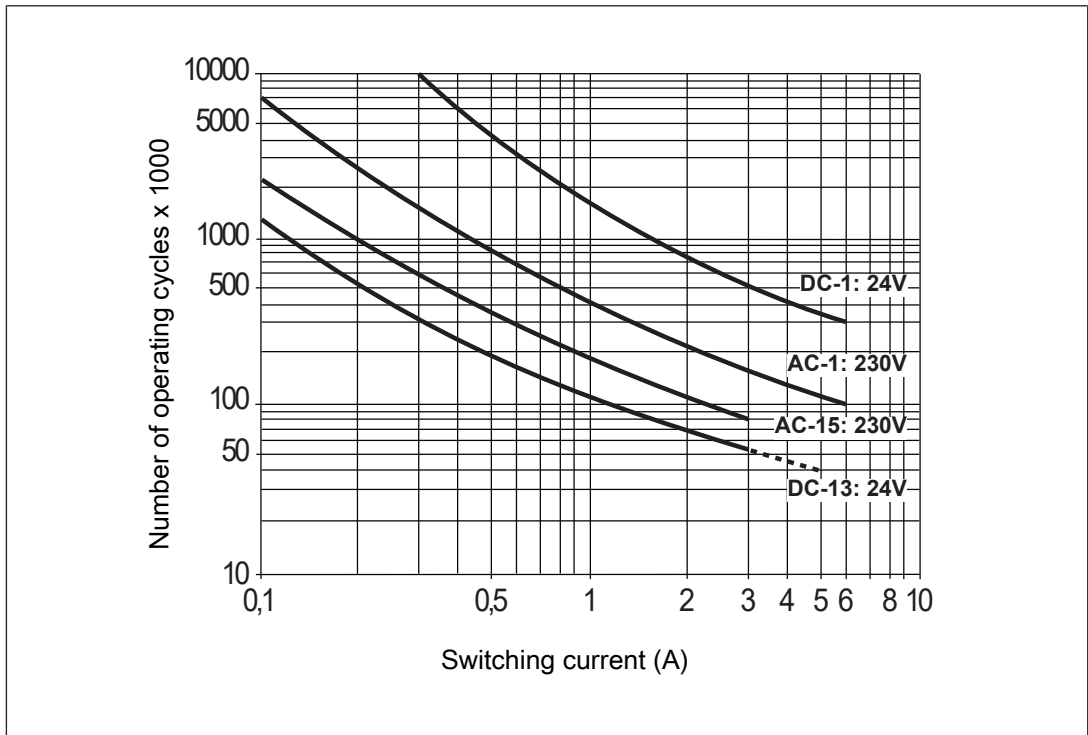

Fig.: Service life graphs at 24 VDC and 230 VAC

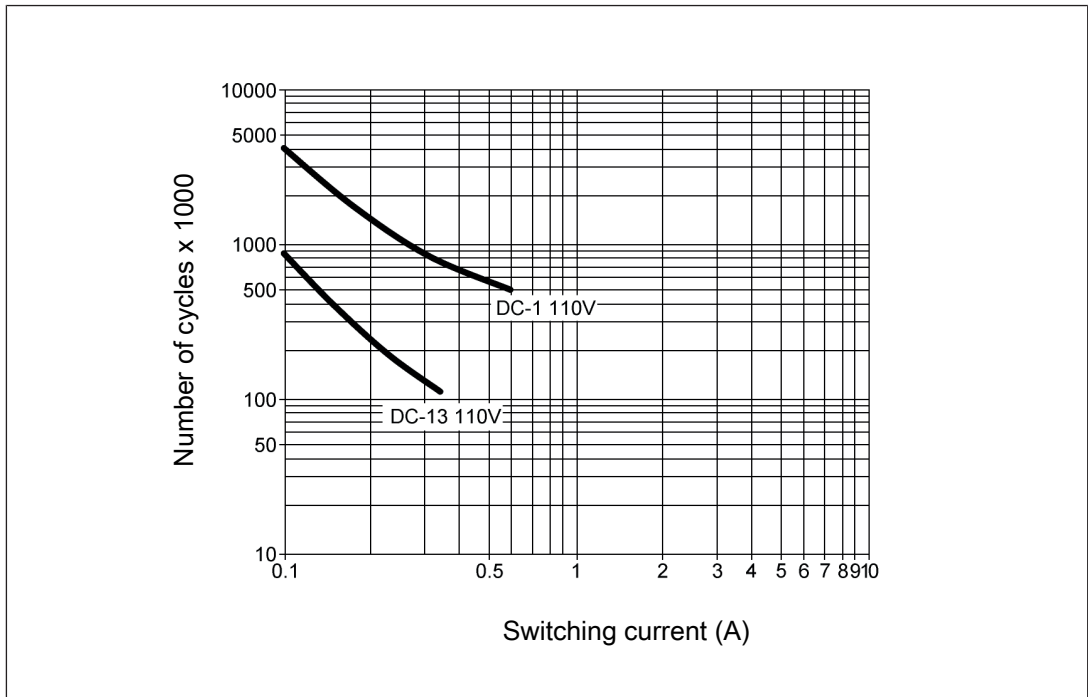

Fig.: Service life graphs at 110 VDC

**Example**

- ▶ Inductive load: 0.2 A
- ▶ Utilisation category: AC15
- ▶ Contact service life: 1 000 000 cycles

Provided the application to be implemented requires fewer than 1 000 000 cycles, the PFH value (see [Technical details \[18\]](#)) can be used in the calculation.

To increase the service life, sufficient spark suppression must be provided on all relay contacts. With capacitive loads, any power surges that occur must be noted. With DC contactors, use flywheel diodes for spark suppression.

## Order reference

Type	Features	Connection type	Order no.
PSWZ X1P C	24 - 240 V AC/DC; 0,02 - 0,5 V; $U_{on}$ : 20 - 500 mV	Spring-loaded terminals	787949
PSWZ X1P	24 - 240 V AC/DC; 0,02 - 0,5 V; $U_{on}$ : 20 - 500 mV	Screw terminals	777949
PSWZ X1P C	24 - 240 V AC/DC; 0,12 - 3 V; $U_{on}$ : 120 - 3000 mV	Spring-loaded terminals	787950
PSWZ X1P	24 - 240 V AC/DC; 0,12 - 3 V; $U_{on}$ : 120 - 3000 mV	Screw terminals	777950
PSWZ X1P C	24 - 240 V AC/DC; 0,0075 - 0,5 V; $U_{on}$ : 7.5 - 500 mV	Spring-loaded terminals	787951
PSWZ X1P	24 - 240 V AC/DC; 0,0075 - 0,5 V; $U_{on}$ : 7.5 - 500 mV	Screw terminals	777951
PSWZ X1P (coated version)	24 - 240 V AC/DC; 0,02 - 0,5 V; $U_{on}$ : 20 - 500 mV	Screw terminals	777959

### Selection guide: Determine remanence voltage

The remanence voltage has to be within the response range of the device.

## EC declaration of conformity

This product/these products meet the requirements of the directive 2006/42/EC for machinery of the European Parliament and of the Council. The complete EC Declaration of Conformity is available on the Internet at [www.pilz.com/downloads](http://www.pilz.com/downloads).

Authorised representative: Norbert Fröhlich, Pilz GmbH & Co. KG, Felix-Wankel-Str. 2, 73760 Ostfildern, Germany

## UKCA-Declaration of Conformity

This product(s) complies with following UK legislation: Supply of Machinery (Safety) Regulation 2008.

The complete UKCA Declaration of Conformity is available on the Internet at [www.pilz.com/downloads](http://www.pilz.com/downloads).

Representative: Pilz Automation Technology, Pilz House, Little Colliers Field, Corby, Northamptonshire, NN18 8TJ United Kingdom, eMail: [mail@pilz.co.uk](mailto:mail@pilz.co.uk)

# ► Support

Technical support is available from Pilz round the clock.

## Americas

### Brazil

+55 11 97569-2804

### Canada

+1 888 315 7459

### Mexico

+52 55 5572 1300

### USA (toll-free)

+1 877-PILZUSA (745-9872)

## Asia

### China

+86 21 60880878-216

### Japan

+81 45 471-2281

### South Korea

+82 31 778 3300

## Australia and Oceania

### Australia

+61 3 95600621

### New Zealand

+64 9 6345350

## Europe

### Austria

+43 1 7986263-0

### Belgium, Luxembourg

+32 9 3217570

### France

+33 3 88104003

### Germany

+49 711 3409-444

### Ireland

+353 21 4804983

### Italy, Malta

+39 0362 1826711

## Scandinavia

+45 74436332

## Spain

+34 938497433

## Switzerland

+41 62 88979-32

## The Netherlands

+31 347 320477

## Turkey

+90 216 5775552

## United Kingdom

+44 1536 462203

## You can reach our international hotline on:

+49 711 3409-222

support@pilz.com

Pilz develops environmentally-friendly products using ecological materials and energy-saving technologies. Offices and production facilities are ecologically designed, environmentally-aware and energy-saving. So Pilz offers sustainability, plus the security of using energy-efficient products and environmentally-friendly solutions.



We are represented internationally. Please refer to our homepage [www.pilz.com](http://www.pilz.com) for further details or contact our headquarters.

Headquarters: Pilz GmbH & Co. KG, Felix-Wankel-Straße 2, 73760 Ostfildern, Germany  
Telephone: +49 711 3409-0, Telefax: +49 711 3409-133, E-Mail: [info@pilz.com](mailto:info@pilz.com), Internet: [www.pilz.com](http://www.pilz.com)

**PILZ**  
THE SPIRIT OF SAFETY

CECE®, CHRE®, CMSE®, InduraNET p®, Leansafe®, Master of Safety®, Master of Security®, PAS4000®, PAScall®, PASconfig®, Pilz®, PTT®, PLID®, PMCPirimo®, PMCPiritego®, PMCTendo®, PMD®, PMJ®, PNOZ®, PRCM®, PRM®, PRTM®, PSEN®, PSS®, PVS®, SafetyBUS p®, SafetyEYE®, SafetyNET p®, THE SPIRIT OF SAFETY® are registered and protected trademarks of Pilz GmbH & Co. KG in some countries. We would point out that product features may vary from the details stated in this document, depending on the status at the time of publication and the scope of the equipment. We accept no responsibility for the validity, accuracy and entirety of the text and graphics presented in this information. Please contact our Technical Support if you have any questions.

21005-EN-14, 2023-05 Printed in Germany  
© Pilz GmbH & Co. KG, 2019