

MiniCAS II, 24 VAC/DC, 120 VAC and 230 VAC Supervision relay

Table of Contents

TECHNICAL DATA.....	2
Technical data.....	2

TECHNICAL DATA

Technical data

Xylem Flygt MiniCAS II is a supervision relay for temperature and leakage sensors. It is designed for the 3000 series pumps up to model 3301 and for the mixer program.

A number of condition monitoring sensors are available for the Xylem FLYGT pump range.

- **Thermal switches** for stator overtemperature.
- **CLS** for water in oil detection.
- **FLS** for detection of liquid in the stator housing.
- **FLS10** for detection of liquid in the inspection chamber in the new midrange pump series, eg 3153, 3171, 3202 and 3301.

The sensors can be used in any desired combination.

For "Ex" certified pumps only combinations involving thermal switches, FLS and FLS10 may be used.

On the front, there are three indication lamps, one for supply, one for temperature alarm and one for leakage alarm. For the communication between the pump and the MiniCAS II, only two wires are needed. The MiniCAS II is designed to be connected to a standard 11-pin socket.

MiniCAS II is interchangeable with the original version of MiniCAS.

Operational principle:	Current Sensing
Approvals:	CE, C-UR (covering USA and Canada) and CSA
Environment:	-25 to +60°C. maximum 90% relative humidity
Supply voltage 24 VAC/DC:	24 VAC, -17% –+25% (50-60Hz) 24 VDC, -2% –+25%
Supply voltage 120 VAC:	120 VAC, -15% –+15% (50-60 Hz)
Supply voltage 230 VAC:	230 VAC, -15% –+15% (50-60 Hz)
Relay contact rating:	250 VAC / 5A
Voltage to sensor:	12 V DC +/-5%
Values of operation:	3 mA < I < 22 mA = OK condition I < 3 mA = High Temperature (or interruption) I > 22 mA = Leakage (or short circuit), delay 10 sec. (I = current measured by MiniCAS II)
Power supply required:	5 VA

OPERATION

Leakage:	Changeover contacts	11-8 Normally closed for Interlock 11-9 Normally open, closes for Alarm
	Automatic reset	
	Red LED for indication - follows the relay	
	Red indication lamp on:	Leakage

	Red indication lamp off:	No leakage
Temperature:	Changeover contacts	1-3 Normally open, closes for Interlock 1-4 Normally closed for Alarm
	Manual reset (see below)	
	Red Indication lamp on:	Overtemperature
	Red Indication lamp off:	Normal temperature
Reset of temperature alarm:	External reset is possible either by connecting terminals 6 - 7 with an external push button or by interrupting the supply voltage. Note, in the 24 V version, Reset is also possible between 6-2.	
Supply:	Yellow indication lamp on:	Supply on
	Yellow indication lamp off:	Supply off
DIMENSIONS (WxHxD)	33 mm x 79 mm x 75 mm	
PART NOS:	83 58 57 (24 VAC/DC) 40 501098 (120 VAC) 40 501560 (230 VAC)	

CONNECTIONS

Leakage alarm will stop the pump

This installation can be used if the leakage alarm shall stop the pump. It is recommended if the FLS sensor is used. The FLS is detecting liquid in the stator housing, which is critical and requires a quick stop of the pump.

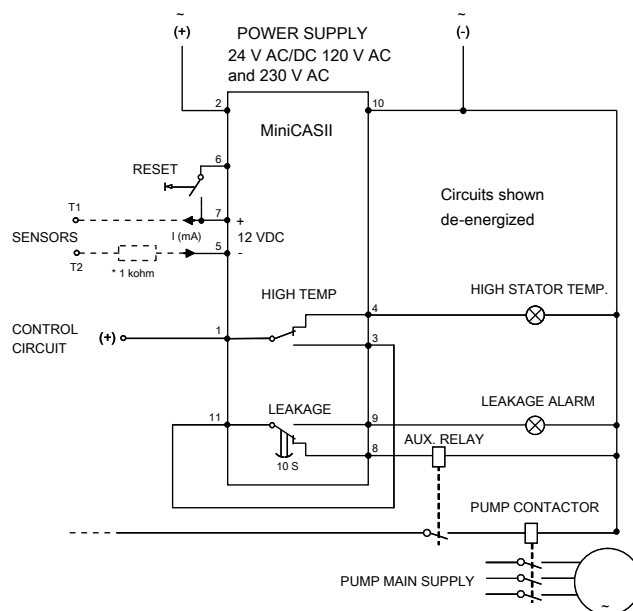

*) Fit resistor to avoid short circuit if only thermal contacts are

Figure 1

Note, in the 24 V version RESET is also possible between 6-2.

Leakage alarm will not stop the pump (only warning)

This installation can be used if the leakage alarm shall not stop the pump but give a warning on the MiniCASII.

It is recommended if FLS10 in inspection chamber or CLS is used. These sensors detect liquid in the inspection chamber (FLS10) and water in the oil (CLS), which is less critical than water in the stator housing.

FLS10 is used in the new midrange pump series, eg 3153, 3171, 3202 and 3301.

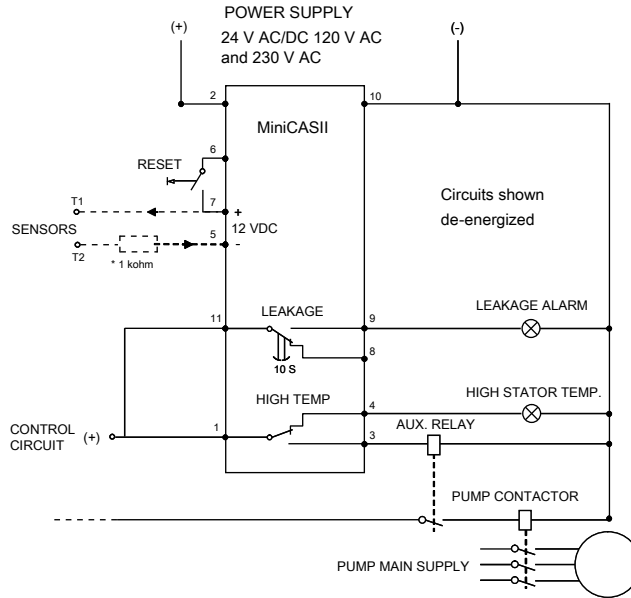

*) Fit resistor to avoid short circuit if only thermal contacts are

Figure 2

Xylem |'zīləm|

- 1) The tissue in plants that brings water upward from the roots
- 2) A leading global water technology company

We're 12,000 people unified in a common purpose: creating innovative solutions to meet our world's water needs. Developing new technologies that will improve the way water is used, conserved, and re-used in the future is central to our work. We move, treat, analyze, and return water to the environment, and we help people use water efficiently, in their homes, buildings, factories and farms. In more than 150 countries, we have strong, long-standing relationships with customers who know us for our powerful combination of leading product brands and applications expertise, backed by a legacy of innovation.

For more information on how Xylem can help you, go to xylem.com



Xylem Water Solutions AB
Gesällvägen 33
174 87 Sundbyberg
Sweden
Tel. +46-8-475 60 00
Fax +46-8-475 69 00
<http://tpi.xylem.com>

Visit our Web site for the latest version of this document and more information

The original instruction is in English. All non-English instructions are translations of the original instruction.

© 2011 Xylem Inc