

be in motion be in motion

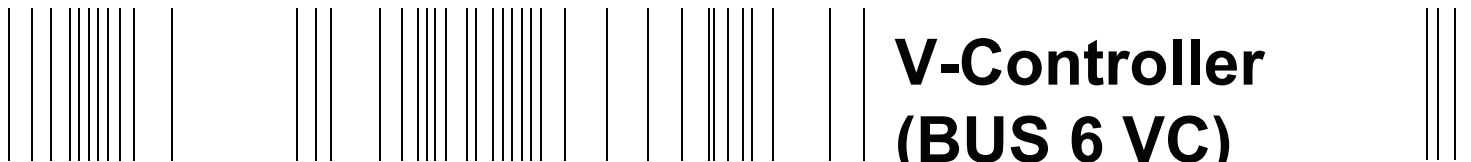

**V-Controller
(BUS 6 VC)**

SW 2.XX

Manual

E

5.95036.11a



BAUMÜLLER

Title	Manual
Product	V-Controller (BUS 6 VC)
Version	5.95036.11a
Copyright	<p>These operating instructions may be copied by the owner in any quantity but only for internal use. For other purposes these operating instructions and extracts thereof must not be copied or reproduced.</p> <p>Use and disclosure of information contained in these operating instructions are not permitted.</p> <p>Designations and company marks contained in these operating instructions may be brand names, the use of which by third parties for their own purposes may violate the rights of the holders.</p>
Obligatory	<p>These operating instructions are part of the equipment/machine. These operating instructions must be available to the operator at all times and must be in a legible condition. If the equipment/machine is sold or moved to a different location these operating instructions must be passed on by the owner together with the equipment/machine.</p> <p>After any sale of the equipment/machine this original and all copies must be handed over to the buyer. After disposal or any other end of use this original and all copies must be destroyed.</p> <p>When the present operating instructions are handed over, corresponding sets of operating instructions of a previous version are automatically invalidated. Please notice that specifications/data/information are current values according to the printing date. These statements are not legally binding according to the measurement, computation and calculations.</p> <p>Baumüller Nürnberg GmbH reserves the right, in developing its products further, to change the technical specifications and the handling of the products concerned without prior notice.</p> <p>No liability can be accepted concerning the correctness of the operating instructions unless otherwise specified in the General Conditions of Sale and Delivery.</p>
Manufacturer	<p>Baumüller Nürnberg GmbH Ostendstr. 80 - 90 D-90482 Nürnberg Germany Tel. +49 9 11 54 32 - 0 Fax: +49 9 11 54 32 - 1 30 www.baumueller.de</p>

TABLE OF CONTENTS

1	Safety Information	7
2	Technical Data	9
2.1	General	9
2.2	Electrical Data	11
2.3	Type Code	12
3	Transportation, Unpacking	15
4	Assembly	17
4.1	Dimensions	17
4.2	Assembly Note	18
5	Installation	19
5.1	Danger Information	19
5.2	Checks Prior to Installation	20
5.3	Display	21
5.3.1	Seven-segment Display	21
5.3.2	LED Display Element	22
5.4	Terminal Diagram	23
5.5	Connection of the Function Inputs	24
5.6	Connector Pin Assignment	25
5.7	Connection cable	30
5.7.1	Connection Cable all Encoder Types	30
5.7.2	Serial Connection Cable for PC	31
5.7.3	Connection Cable RS485	33
5.7.4	Interface Adapter	34
5.7.5	Connection of Leading Axis and Following Axis	35
5.8	Accessories	36
6	Commissioning	37
6.1	Danger Information	37
6.2	Initial Commissioning of V-Controller	40
6.3	Locating Position Reference Point Setting	52
6.4	Commands to Start the Drive	53
6.5	Commands to Stop the Drive	54
7	Parameter	55
7.1	Function Diagrams	55
7.2	Power Supply	59
7.3	Power Unit	61
7.4	Pulse Width Modulation	67
7.5	Motor Model	69
7.6	Overload Monitoring	74
7.7	Motor Temperature Monitoring	77
7.8	Field Angle Calculation	80
7.9	Encoder Manager	83

Table of Contents

7.10 Evaluation Encoder 1 and Encoder 2	86
7.11 Current Controller	94
7.12 Speed Controller	98
7.13 Torque Monitoring	101
7.14 Position Controller	103
7.15 Drive Manager	109
7.16 Data Set Management	127
7.17 Operation System	133
7.18 Ramp Function Generator	135
7.19 Set Value Generator	138
7.20 Motor Potentiometer	140
7.21 Synchronisation Control	142
7.22 Analog Inputs	147
7.23 Analog Outputs	151
7.24 LED Display	153
7.25 Digital Inputs	156
7.26 Digital Outputs	161
7.27 External Digital input	164
7.28 External Digital Outputs	167
7.29 Service Interface	170
7.30 Link to USS® Protocol	175
7.31 BAPS Communication	189
7.32 Additional Parameter	191
7.33 Parameter List	192
8 Maintenance	201
8.1 Maintenance Information	201
8.2 Error Messages	202
9 Appendix	207
9.1 Manufacturer Declaration	207
9.2 Conditions of Business and Delivery	208
9.3 Index	209

ABBREVIATIONS

AC	Alternating current	PI	Parameter identification
ADR	Address byte	PIV	Parameter identification value
AI	Function module analog inputs	PN	Parameter no.
AM	Asynchronous motor	PS	Function module power supply
AO	Function module analog outputs	PV	Parameter value
BAPS	Baumüller parallel interface	PWM	Function module pulse width modulation
BASS	Baumüller serial interface	RFG	Function module ramp function generator
BCC	Block check character	SM	Synchronous motor
BOF	Begin of file	STX	Start of text
BSA	Reference potential analog	SV	Function module service interface
BSD	Reference potential digital	SVG	Function module set value generator
CE	Controller enabling	TM	Temperature motor
CPU	Central Processing Unit	USS®	Function module interface to USS® protocol
CT	Function module coordinate transformation	ZK	Intermediate circuit
DA	Digital analog		
DC	Direct current		
DI	Function module digital inputs		
DSM	Function module data set management		
EOF	End of file		
Ext	Function module current monitoring		
MC	Main conductor		
MCO	Main conductor on		
MOE	Enable main conductor		
I	Function module current control		
I2t	Function module overload monitoring		
Inc	Unit of position counter		
IND	Index		
Ink	No. of graduation marks		
J/RI	Job / reply identification		
LED	Leuchtdiode		
LGE	Telegram length		
LT	Function module power unit		
M	Function module drive manager		
MM	Function module motor model		
Mot	Function module field angle calculation		
MT	Function module motor temperature		
N	Function module speed controller		
OS	Function module operation system		
P	Parameter number		
P	Function module position controller		
Para.	Paragraph		
PD	Process data		
PD	Parameter description		

1 SAFETY INFORMATION

General Information

These operating instructions contain all the information necessary for correct operation of the products described. The document is intended for specially trained, technically qualified personnel who are well-versed in all warnings and commissioning activities. The equipment is manufactured using state-of-the-art technology and is safe in operation. It can safely be installed and commissioned and functions without problems if the safety information in these operating instructions is followed.



WARNING

When operating electrical equipment, some parts of the equipment always carry dangerous voltages. Ignoring these safety instructions and warnings may result in serious personal injury and/or damage to property.

Only qualified personnel who are familiar with the safety information, assembly, operation and maintenance instructions may carry out work on this equipment.

Danger Information

On the one hand, the information below is for your own personal safety and on the other to prevent damage to the described products or to other connected equipment.

In the context of the operating instructions and the information on the products themselves, the terms used have the following meanings:



DANGER

This means that death, severe personal injury, or damage to property will occur unless appropriate safety measures are taken.



WARNING

This means that death, severe personal injury, or damage to property may occur unless appropriate safety measures are taken.

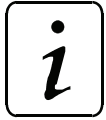

NOTE

This draws your attention to important information about the product, handling of the product or to a particular section of the documentation.

Qualified Personnel

In the context of the safety-specific information in this document or on the products themselves, qualified personnel are considered to be persons who are familiar with setting up, assembling, commissioning and operating the product and who have qualifications appropriate to their activities:

Trained or instructed or authorized to commission, ground and mark circuits and equipment in accordance with recognized safety standards.

Trained or instructed in accordance with recognized safety standards in the care and use of appropriate safety equipment.

Appropriate Use



WARNING

You may only use the equipment/system for the purposes specified in the operating instructions and in conjunction with the third-party equipment and components recommended or authorized by BAUMÜLLER NÜRNBERG GmbH.

For safety reasons, you must not change or add components on/to the equipment/system.

The machine minder must report immediately any changes that occur which adversely affect the safety of the equipment/system.

2 TECHNICAL DATA

2.1 General

The motor controller designated as the V controller is a favourably priced, fully digital solution for the Baumüller Modular System equipment range for closed-loop control of synchronous and asynchronous motors.

The V-controller covers the range of functions of the existing E-controller.

In addition, the two VeCon circuits increase the controller's computing power and storage capacity. This results in a significant improvement in the device's closed-loop control properties, quicker communications and increased open-loop control functionality in the closed-loop controller. Various option boards allow you to adapt the BUS 6 V-controller to a vast range of different requirements and applications.

Closed-Loop Control

- Field-oriented closed-loop control for synchronous motors with
 - Sinus encoder with 5 V synchronous-serial interface
 - Sinus encoder with 8V synchronous-serial interface
 - Sinus incremental encoder
 - Square wave incremental encoder
 - Resolver
- Field-oriented closed-loop control for asynchronous motors with
 - Sinus encoder with 5 V synchronous-serial interface
 - Sinus encoder with 8V synchronous-serial interface
 - Sinus incremental encoder
 - Square wave incremental encoder
 - Resolver

Closed-Loop Control Functions

- Speed control at 62.5 μ s
- Position control at 62.5 μ s
- Torque control at 62.5 μ s
- The digital closed-loop control offers
 - Drift-free operation
 - Exceptional concentricity properties
 - Highest levels of control dynamics and rigidity across the entire speed range
 - Control range above 1:3000
- Depending on the requirements, you can operate the controller by means of
 - analog set value setting and digital switching inputs
 - RS485 serial port for drive networking using a busable protocol (compatible with USS protocol)
 - RS232 serial port for PC operation, parameterization, commissioning and service as well as for archiving control parameter to floppy disk.

Inputs / Outputs

- Digital inputs (24 V):
 - Pulse enabling
 - Rapid halt
 - 4 programmable function inputs
- Analog inputs:
 - 2 analog inputs (0 ... ± 10 V), 12 bit resolution
- Serial interfaces:
 - RS232 with a transmission rate of 9600 baud, optical separated
 - RS485 with a transmission rate of 300 to 19200 baud, optical separated
- Digital outputs:
 - 1 relay contact message „ready for use“
 - 3 programmable function outputs
- Analog outputs
 - 2 analog outputs (0 ... ± 10 V), 12 bit resolution

Operation Software

- WinBASS
- Up-/Download with PCBASS
- PCBASS

Optional Boards

- Omega Drive-Line
- InterBus-S interface
- CAN interface
- I/O module MFM-01
- Sercos interface (in preparation)

2.2 Electrical Data

Accuracy of whole system	Calculation accuracy 16 bit
Sampling rate of whole system	62,5 μ s
2 analog inputs voltage range type input resistance resolution	-10 V ... +10 V differential input ca. 40 k Ω 12 bit
6 potential free inputs low level high level input resistance	0 V ... +7.5 V +13 V ... +30 V 2,5 mA
2 analog outputs voltage range maximum output current resolution	-10 V ... +10 V 1 mA 12 bit
1 relay output maximum contact load maximum potential against electronic ground	24 V DC / 1 A 50 V
3 potential free outputs joint supply voltage joint ground output current per output	+ 24 V / 150 mA ground of 24 V external 50 mA
Encoder emulation	no. of increments adjustable
Interfaces	2 encoder interfaces to get absolute position RS485 RS232 service interface

2.3 Type Code

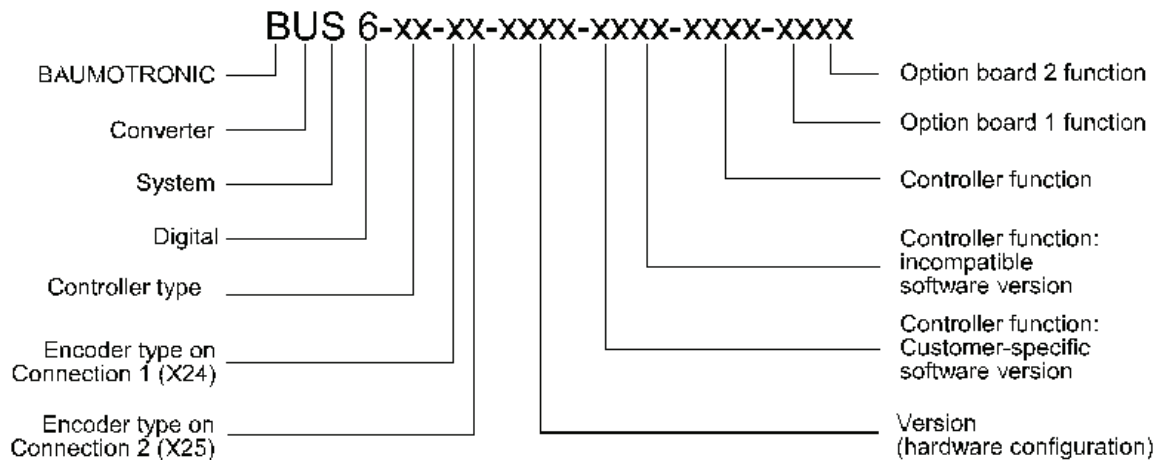

Type of Controller	VC	Vector Controller
Encoder type on connection 1: (X24)	0	No encoder
	A	Resolver
or	B	5 V sinus incremental encoder
Encoder type on connection 2: (X25)	C	Absolute value encoder with 8 V asynchronous serial interface
	D	Absolute value encoder with 5V asynchronous serial interface
	E	5 V square wave incremental encoder
Version:	0001	V-controller
	0002	V-controller with InterBus-S
	etc.	
Closed-Loop Control Function:		
Customer-specific software version	00	No customer-specific software version
Incompatible software version	02	Software version 02.xx
Open-Loop Control Function:	0000	No Omega installed
	Axxx	Run-time software for minimal Omega
	Bxxx	Run-time software for Omega + CAN (multi-axis application)
	Cxxx	Run-time software for minimal Omega + MEM-03
	Dxxx	Run-time software for Omega + CAN (multi-axis application) + MEM-03
	Exxx	Run-time software for Omega + CAN (single-axis application)
	Fxxx	Run-time software for Omega + CAN (single-axis application) + MEM-03
Option Board 1 Function	01	Incompatible software version 01.xx
Option Board 2 Function	00	Software specified by PCB version

Example:

BUS6 - VC - EC - 0008 - 0002 - D103 - 01 - 00

Controller Type:	VC	Vector Controller
Encoder type on connection 1:	E	Square wave incremental encoder
Encoder type on connection 2:	C	Absolute value encoder with asynchronous serial interface and 8 V supply
Version:	0008	V-controller; Omega with MEM-03; InterBus-S with expansion board; multifunction module
Closed-loop control function		
Customer-spec. software version	00	No customer-specific software version
Incompatible software version	02	Software version 02.xx
Open-Loop control function	D103	Run-time software for Omega + CAN (multi-axis application) + MEM-03
Option board 1 function:	01	Incompatible software version 01.xx
Option board 2 function:	00	Software specified via PCB version of option board



NOTE

Compared to the old type code, the positions for the encoder on connection 1 and connection 2 are interchanged.

3 TRANSPORTATION, UNPACKING

The units are packed at the factory in accordance with the order.

You should avoid jolting or dropping the package in transit, e.g. when putting the unit down.

You can start assembly after unpacking the equipment and checking that it is complete and undamaged .

The equipment is packed in cardboard, corrugated sheeting and/or wooden packaging that you should dispose of in accordance with local regulations.

Report any damage that has occurred in transit immediately.



DANGER

If the unit was damaged in transit, a qualified person must check, repair and test it before it may be connected.

Ignoring this information can result in death, serious personal injury or considerable damage to property.

4 ASSEMBLY

4.1 Dimensions

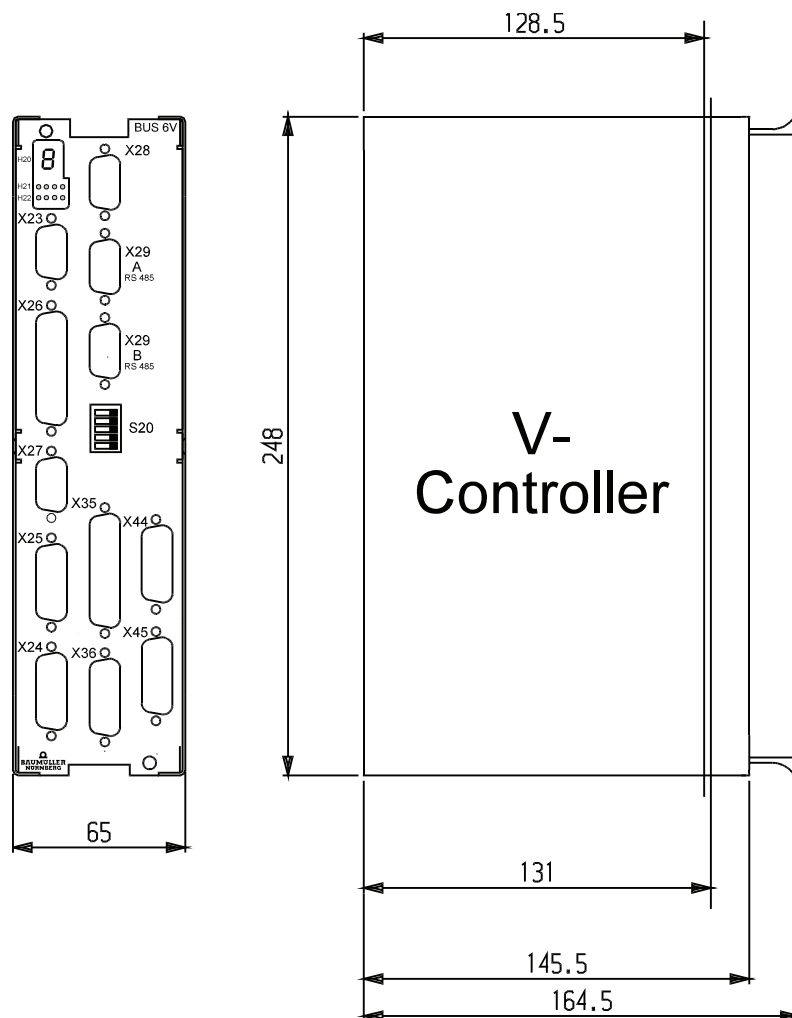

Plug-in depth of cassette

- BUS 6 and BUM 62: 128.5 mm
- BUM 63/64: 131.0 mm

The total depth can only be determined in conjunction with the basic unit. In addition, it is necessary to take into account the dimensions of the connector to be used (approx. 40 mm).

4.2 Assembly Note



WARNING

You are responsible for mounting the described equipment, the motor, the transformer and any other equipment in accordance with appropriate safety regulations (e.g. EN, DIN, VDE); equally you must ensure that all other relevant national or local regulations are met with regard to cable ratings and protection, grounding, disconnectors, overcurrent protection, etc.

During operation, the unit is protected from direct contact such that it is suitable for use in enclosed electrical premises (DIN VDE 0558 Part 1/07.87, Section 5.4.3.2, provisional standard EN 50178/VDE 0160/ 11.94, Sections 5.2.6, 5.2.7).

Plug the controller cassette into the appropriate recess in the basic unit and secure it with the two screws attached to it.



NOTE

Do not plug in the cassette under voltage!

The installation of the basic units is covered separately.

5 INSTALLATION

5.1 Danger Information



WARNING

This equipment carries a dangerously high voltage and has dangerous rotating parts (fans). Ignoring the safety and warning information may result in death, severe personal injury or damage to property.

You are responsible for mounting the power converter, the motor, the commutating reactor and any other equipment in accordance with appropriate safety regulations (e.g. DIN, VDE); equally, you must ensure that all other relevant national and local regulations are met with regard to cable ratings and protection, grounding, disconnectors, overcurrent protection, etc.

The power converter's power cables are energized!

During operation, the principles on which the power converter and the motor work lead to leakage currents to earth that are dissipated via the specified protective earths and may result in a current-operated e.l.c.b. on the input side blowing prematurely.

Speed monitoring systems in the equipment must not just be complemented by a stand-alone monitoring system on the motor in the case of speed-critical drives. You can implement this control of the RPM speed, which is independent of the controller, by means of inductive, optical or torque-dependent encoders. Refer to the appropriate motor's operating and maintenance instructions.

Be particularly careful before touching the drive shaft directly or indirectly with your hands. This is only allowed when the system is deenergized and the drive is stationary.

Safety devices must never be deactivated.

According to applicable regulations (EN 60204 Part 1 and VDE 0113 Part 1), stopping the drive using the enable inputs of the control electronics does not, on its own, represent a safe stop condition. A disturbance in the power converter's control electronics can lead to accidental starting of the motor.

5.2 Checks Prior to Installation

- Note down the type code of the unit and motor
- Check the connections by means of the terminal diagram
- Connection of the plugs:

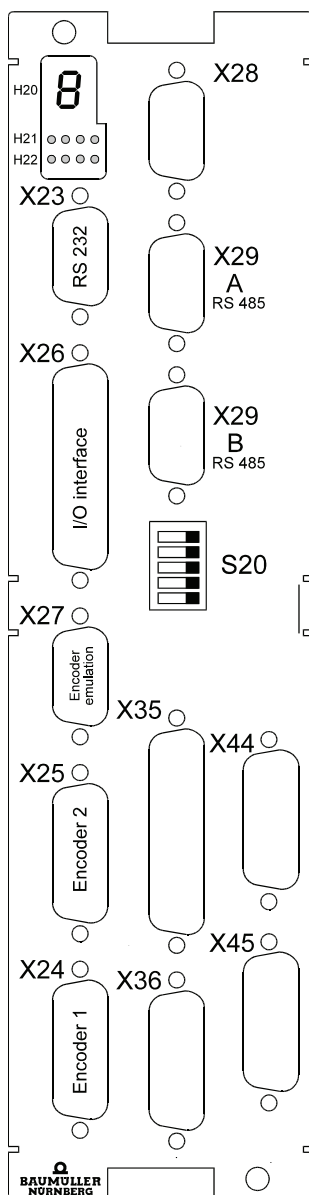

- PC connection via standard RS232
Drive address set in binary code via DIP switch S20
- The locations of the plugs change as a result of various expansions of the standard V-Controller, e.g. by InterBus-S interface or mega Drive-Line. Plug labelling and connector pin assignment, however, remains the same (see corresponding supplementary description).

5.3 Display

5.3.1 Seven-segment Display

A 7-segment display is attached to the front of the V-Controller, which shows the state in the drive manager's state machine (P120 - P133)..

Display	Meaning
0	NOT READY TO START
1	INHIBIT START
2	READY TO START
3	SWITCHED ON
4	OPERATION ENABLED
5	OPERATION ENABLED; command „operation disabled“ active
6	OPERATION ENABLED; command „shut down“ active
7	RAPID_HALT_ACTIVE
E	FAULT_REACTION_ACTIVE
F	FAULT

The following display mode is active **only** in the disturbance status:

Initially status identifier "F" is shown for three seconds to indicate the fault status. The "F" is followed by the four digits of the error code. The system outputs them with a decimal point, which clearly differentiates this status from the others in the device control. After the last digit, the system deactivates the display – apart from the decimal point – for one second. After this, the entire procedure is repeated.

If several errors are pending, the system, displays the entire list in this way.

If you acknowledge an error that is just being shown in display mode, the system still continues to display it until the end of this sequence. The next time the error list is processed, this error is no longer visible.

Example in the case of error codes 0801 and 0202:

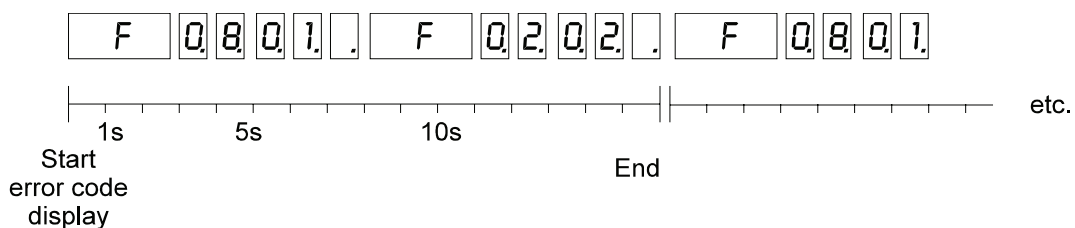

5.3.2 LED Display Element

An LED display, which gives additional information, is located below the 7-segment display.

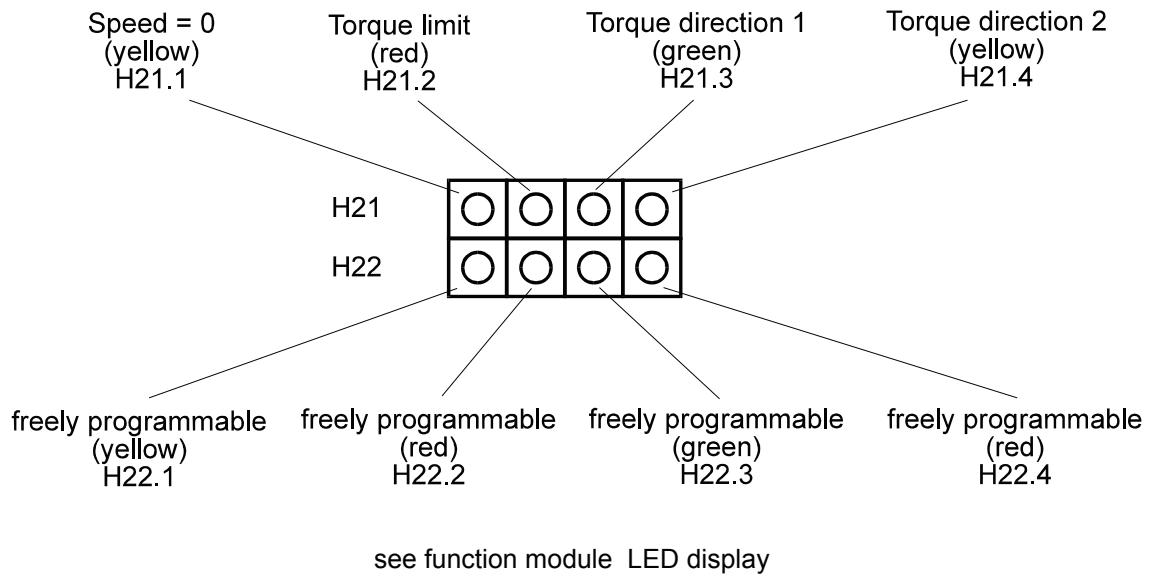

5.4 Terminal Diagram

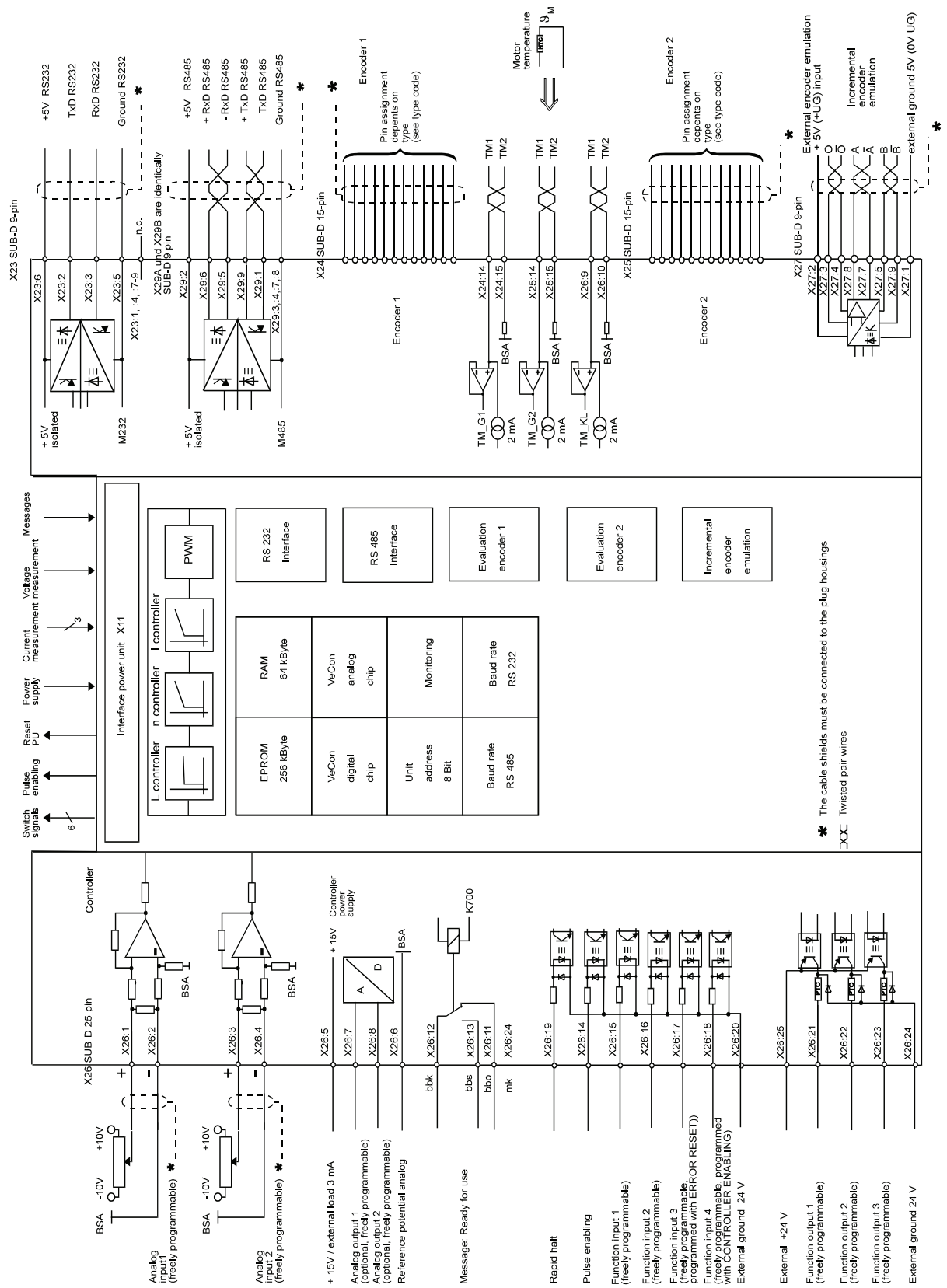

5.5 Connection of the Function Inputs

**M Mode P136 = 0 (Errors are acknowledged separately)
P136 = 1 (All errors are acknowledged together, default setting)**

The parameter of the module digital inputs must be programmed as follows:

Digital input 3 P378 = 120	Digital input 4 P342 = 120
P379 = 0080 _{hex}	P343 = 0008 _{hex}
P380 = 0000 _{hex}	P380 = 0000 _{hex}
P381 = 0080 _{hex}	P381 = 0008 _{hex}

Rapid halt
Pulse enabling
Function input 1 (freely programmable)
Function input 2 (freely programmable)
Function input 3 (freely programmable, programmed with **ERROR RESET**)
Function input 4 (freely programmable, programmed with **CONTROLLER ENABLING**)
External ground 24 V

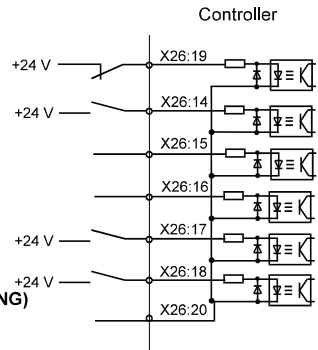

**M Mode P136 = 2 (Errors are acknowledged separately)
P136 = 3 (All errors are acknowledged together)**

The parameter of the module digital inputs must be programmed as follows:

Digital input 4
P342 = 120
P343 = 0008_{hex}
P380 = 0000_{hex}
P381 = 0008_{hex}

Rapid halt
Pulse enabling / ERROR RESET
Function input 1 (freely programmable)
Function input 2 (freely programmable)
Function input 3 (freely programmable)
Function input 4 (freely programmable, programmed with **CONTROLLER ENABLING**)
External ground 24 V

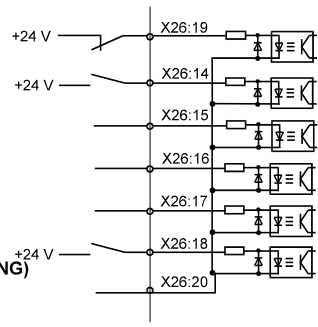

**M Mode P136 = 4 (Errors are acknowledged separately)
P136 = 5 (All errors are acknowledged together)**

The parameter of the module digital inputs must be programmed as follows:

Digital input 3
P378 = 120
P379 = 0080_{hex}
P380 = 0000_{hex}
P381 = 0080_{hex}

Rapid halt
Pulse enabling / CONTROLLER ENABLING
Function input 1 (freely programmable)
Function input 2 (freely programmable)
Function input 3 (freely programmable, programmed with **ERROR RESET**)
Function input 4 (freely programmable)
External ground 24 V

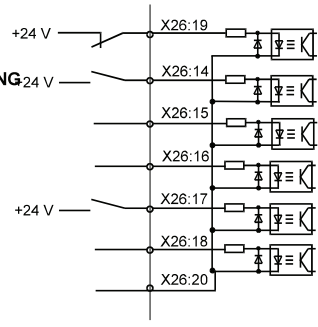

**M Mode P136 = 6 (Errors are acknowledged separately)
P136 = 7 (All errors are acknowledged together)**

Rapid halt
Pulse enabling / CONTROLLER ENABLING / ERROR RESET
Function input 1 (freely programmable)
Function input 2 (freely programmable)
Function input 3 (freely programmable)
Function input 4 (freely programmable)
External ground 24 V

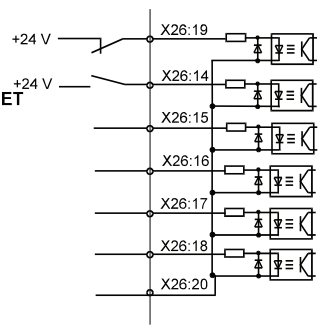

NOTE

All the enables are edge-triggered except for the emergency stop input. The emergency stop input must be active before the other hardware enables.

5.6 Connector Pin Assignment

RS232 Interface

X 23 SUB-D socket 9-pin

Socket

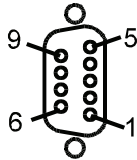

Pin no.	Assignment
1	not assigned
2	TxD RS232
3	RxD RS232
4	DTR, DSR
5	ground RS232
6	+5V RS232
7	RTS, CTS
8	RTS, CTS
9	not assigned

RS485 Interface

X 29 A SUB-D socket 9-pin

X 29 B SUB-D plug 9-pin

Socket

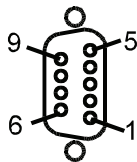

Plug

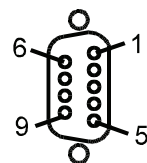

Pin no.	Assignment
1	-TxD RS485
2	+5V RS485
3	ground RS485
4	ground RS485
5	-RxD RS485
6	+RxD RS485
7	ground RS485
8	ground RS485
9	+TxD RS485

Installation

Incremental Encoder Emulation

X27 SUB-D plug 9-pin

Plug

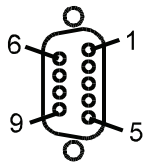

Pin no.	Assignment
1	ground incremental encoder emulation
2	external power supply +5V incremental encoder emulation
3	incremental encoder emulation 0
4	incremental encoder emulation -0
5	incremental encoder emulation B
6	not assigned
7	incremental encoder emulation -A
8	incremental encoder emulation A
9	incremental encoder emulation -B

Resolver

X24 / X25 SUB-D socket 15-pin (depends on type, X24 or X25)

Socket

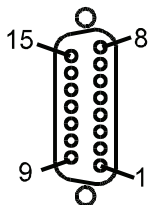

Pin no.	Assignment
1	resolver ref+
2	resolver ref-
3	not assigned
4	not assigned
5	resolver cos-
6	not assigned
7	resolver sin+
8	resolver sin-
9	resolver cos+
10	reserved*
11	reserved*
12	not assigned
13	not assigned
14	temperature motor TM1
15	temperature motor TM2

* do not assign

**Rectangle Incremental Encoder (e. g. Heidenhain ROD 426)
Sine Incremental Encoder 5V (e. g. Heidenhain ROD 486)**

X 24 / X 25 SUB-D socket 15-pin (depends on type, X 24 or X 25)

Socket

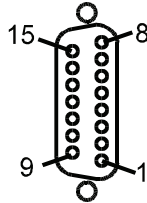

Pin no.	Assignment
1	ground
2	+5V encoder voltage
3	RS422 encoder +U0
4	RS422 encoder -U0
5	RS422 encoder +U2
6	not assigned
7	RS422 encoder -U1
8	RS422 encoder +U1
9	RS422 encoder -U2
10	not assigned
11	not assigned
12	reserved*
13	reserved*
14	temperature motor TM1
15	temperature motor TM2

* do not assign

Sine Encoder (e. g. Stegmann SCM70, asynchronous serial interface, 8V)

X24 / X25 SUB-D socket 15-pin (depends on type, X24 or X25)

Socket

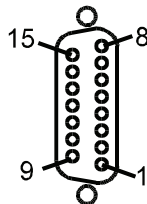

Pin no.	Assignment
1	ground
2	+8V encoder voltage
3	reserved*
4	reserved*
5	COS +
6	not assigned
7	SIN -
8	SIN +
9	COS -
10	not assigned
11	not assigned
12	RS485 +
13	reserved*
14	reserved*
15	RS485 -

* do not assign

Motor Temperature

Sockets X24, X25 and X26 provide three inputs for acquiring the motor temperature. Only one of these inputs may be connected. The other two inputs **must always** be open and cannot be used for additional external evaluation, since this can lead to corrupted measuring results or the destruction of the internal measuring circuit.

Controlling the Temperature Probe:

For this, you must remove the cable that is used to collect the motor temperature from the closed-loop control unit. While the motor is cold (coil temperature of less than 80° C), the resistance between the two connections in the cable must not exceed 1 kΩ.

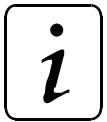
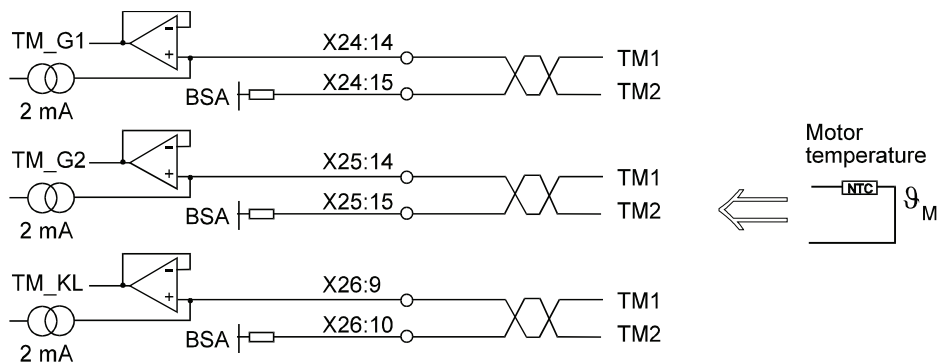

NOTE

The selection of the encoder input is set by parameter P125 MT mode.

Analog/Digital Interface

X26 SUB-D socket 25 pin

Socket

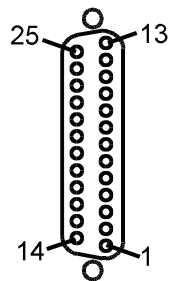

Pin no.	Assignment
1	analog input 1, differential signal +
2	analog input 1, differential signal -
3	analog input 2, differential signal +
4	analog input 2, differential signal -
5	analog power supply, + 15 V
6	analog power supply, reference potential
7	analog output 1
8	analog output 2
9	input motor temperature +
10	input motor temperature -
11	bbo relay break contact ready for use
12	bbk relay changeover contact ready for use
13	bbs relay make contact ready for use
14	pulse enabling (24 V)
15	digital input 1 (24 V)
16	digital input 2 (24 V)
17	digital input 3 (24 V), programmed with controller enabling
18	digital input 4 (24 V), programmed with reset errors
19	rapid halt (24 V)
20	ground for digital inputs 1 to 4 respectively pulse enabling and rapid halt
21	digital output 1 (24 V)
22	digital output 2 (24 V)
23	digital output 3 (24 V)
24	ground digital outputs 1 to 3
25	+24 V for digital inputs 1 to 4, pulse enabling, rapid halt and digital outputs 1 to 3

5.7 Connection cable

5.7.1 Connection Cable all Encoder Types

Cable sets are available for the connection of all encoder types.

BL encoder cable 12/15 pin, article no.: 1901 8001 (lengths on request).

Unit end

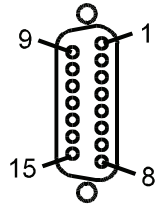

View of mating side
SUB-D plug, 15-pin

Motor end

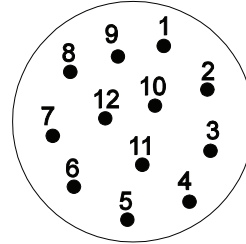

View of mating side
Metal round plug, 12-pin
socket contacts (manufacturer Interconnectron)

Cable: LiYCY 5x(2x0.14)+2x0.5mm² cores twisted in pairs, total shielding via copper.

The cable shield is connected to the round plug housing and the SUB-D plug connector shielding.

Pin no.	Connection	Pin no.
1	blue Ø0.5mm	10
2	red Ø0.5mm	12
3	violet	3
4	grey/pink	4
5	brown	8
6		
7	grey	6
8	yellow	5
9	green	1
10		
11		
12	pink	2
13	blue	11
14	red	9
15	black	7

5.7.2 Serial Connection Cable for PC



NOTE

Connect PC in control cabinet or via isolating transformer.
Refer to additional description WinBASS or Up-/Download for explanation of operating program.

- 9-pin PC connection (interface cable PC, part no. 1901 8006)

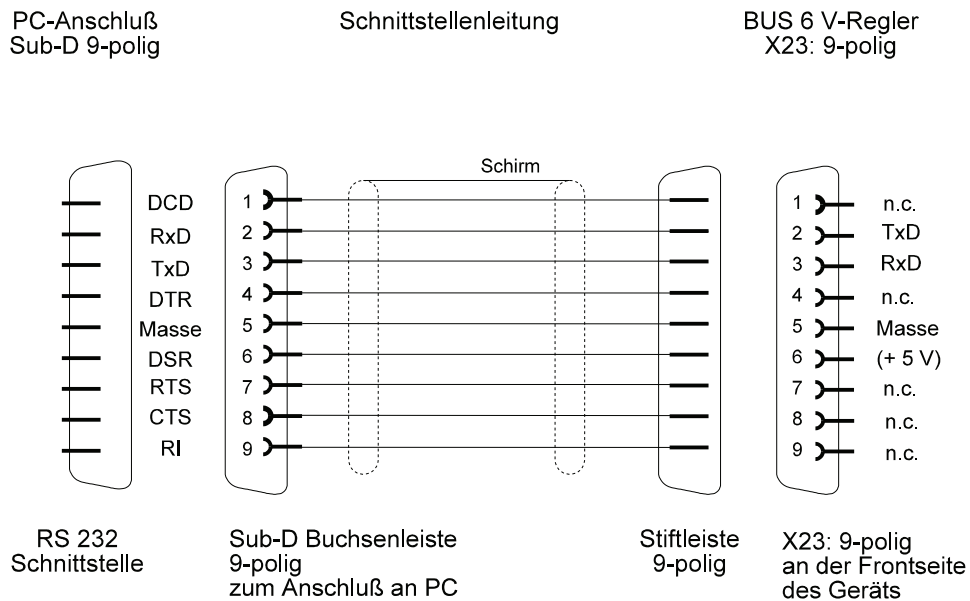

- 25-pin PC connection (not available)

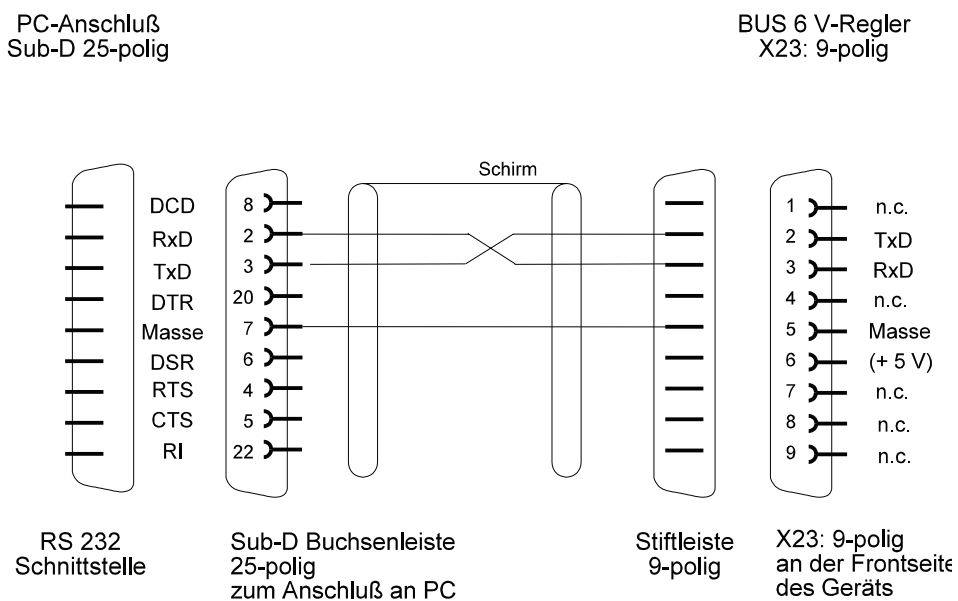

Installation

Connection Terminal Ring Circuit RS232

The units must be connected as follows, if more than one unit (up to 16) are connected in a ring circuit. :

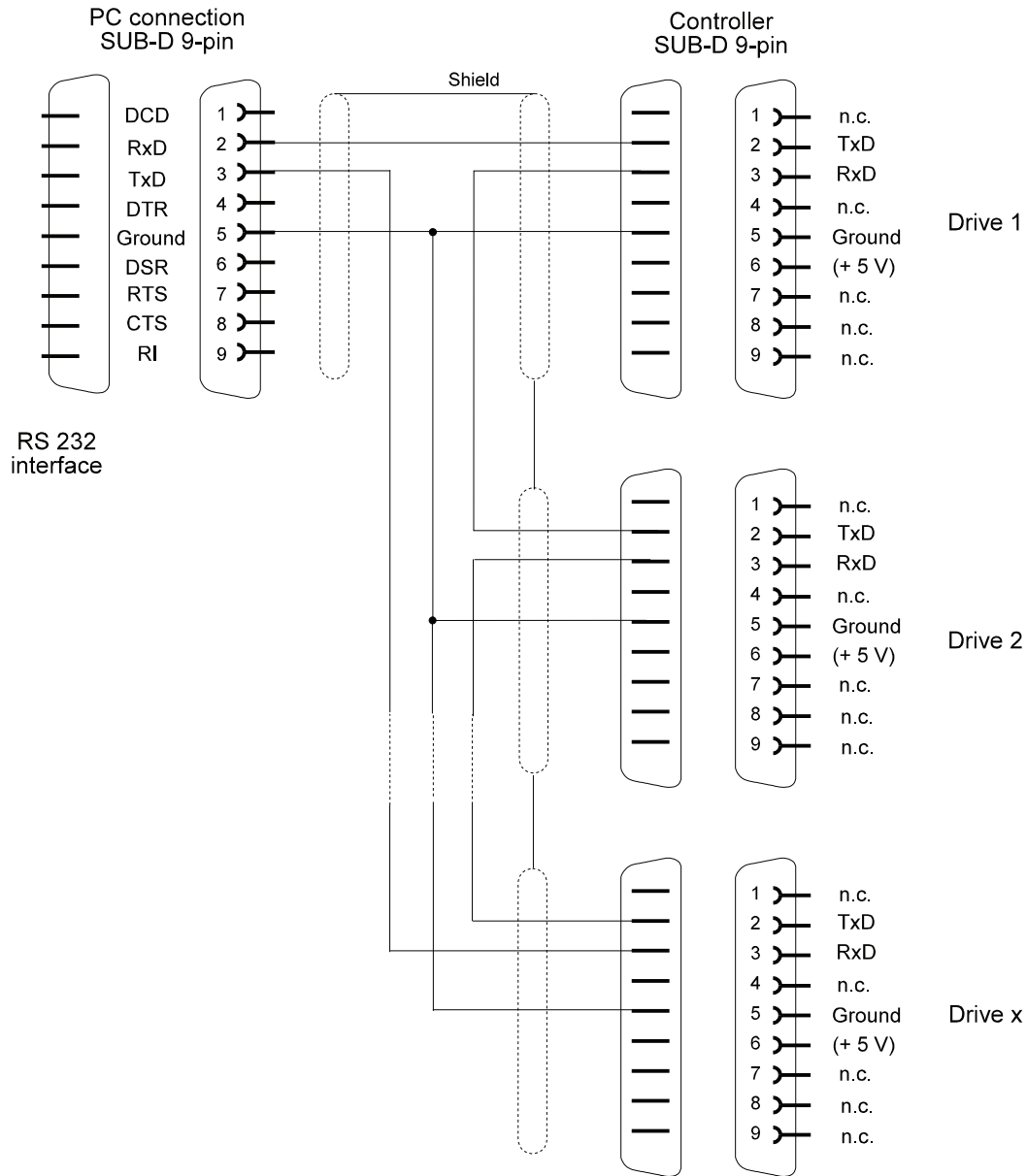

5.7.3 Connection Cable RS485

- 4 wire connection from master to 1. slave

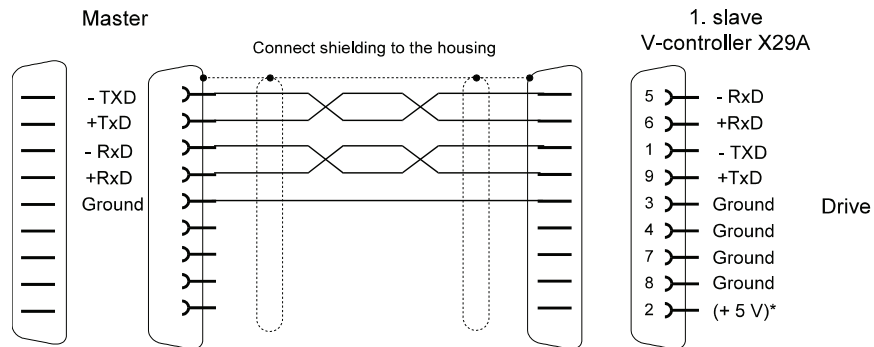

- 2 wire connection from master to 1. slave

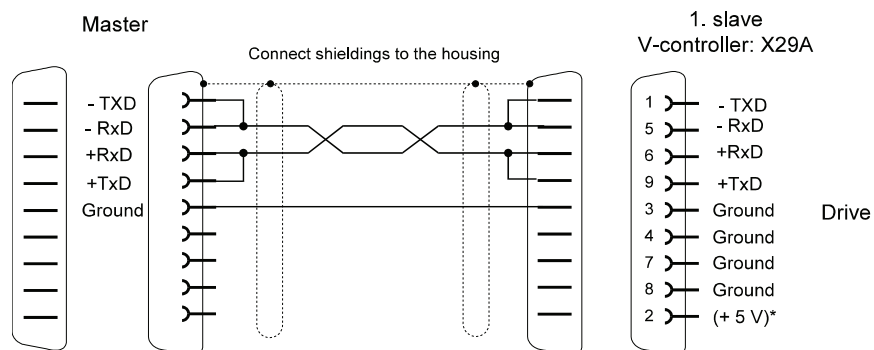

- Connection between 1. slave and 2. slave (and so on)

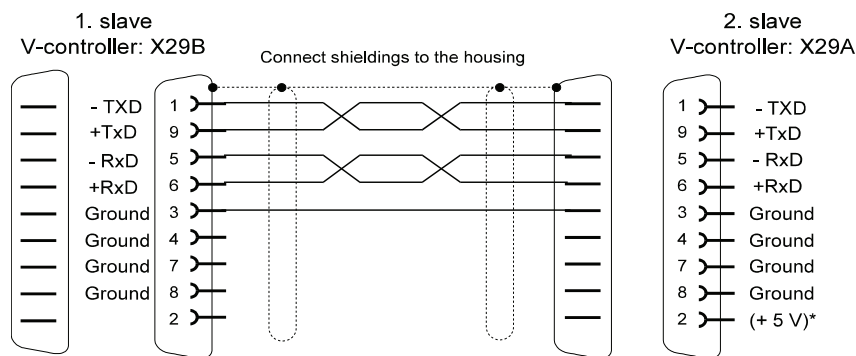

- Terminating socket for the last slave

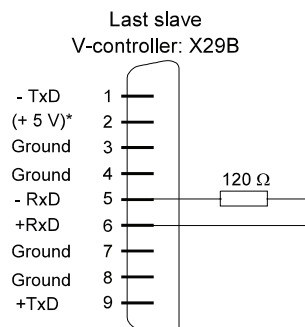

* The +5 V are reserved for the power supply of RS485/RS232 adapters and must be connected.

5.7.4 Interface Adapter

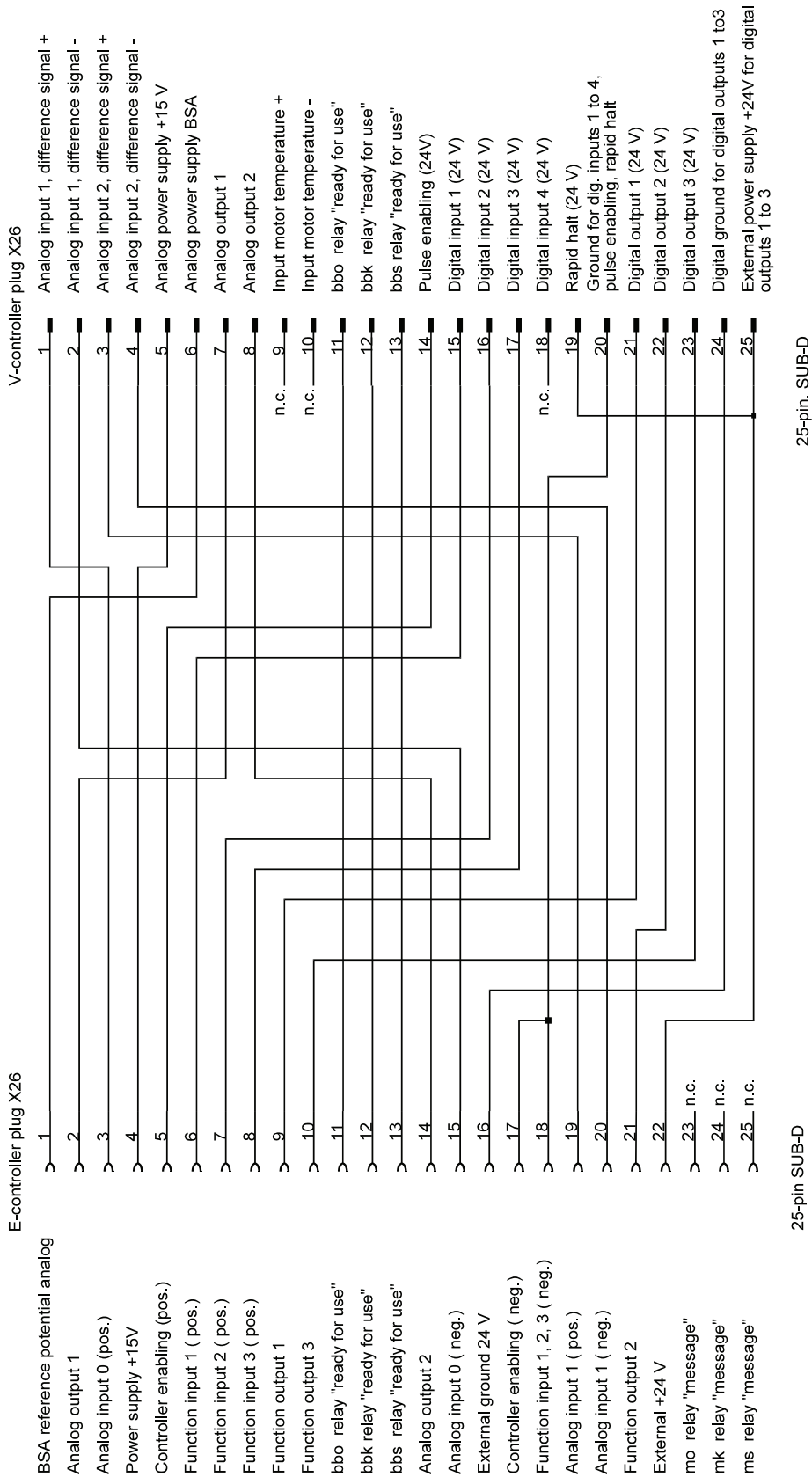

5.7.5 Connection of Leading Axis and Following Axis

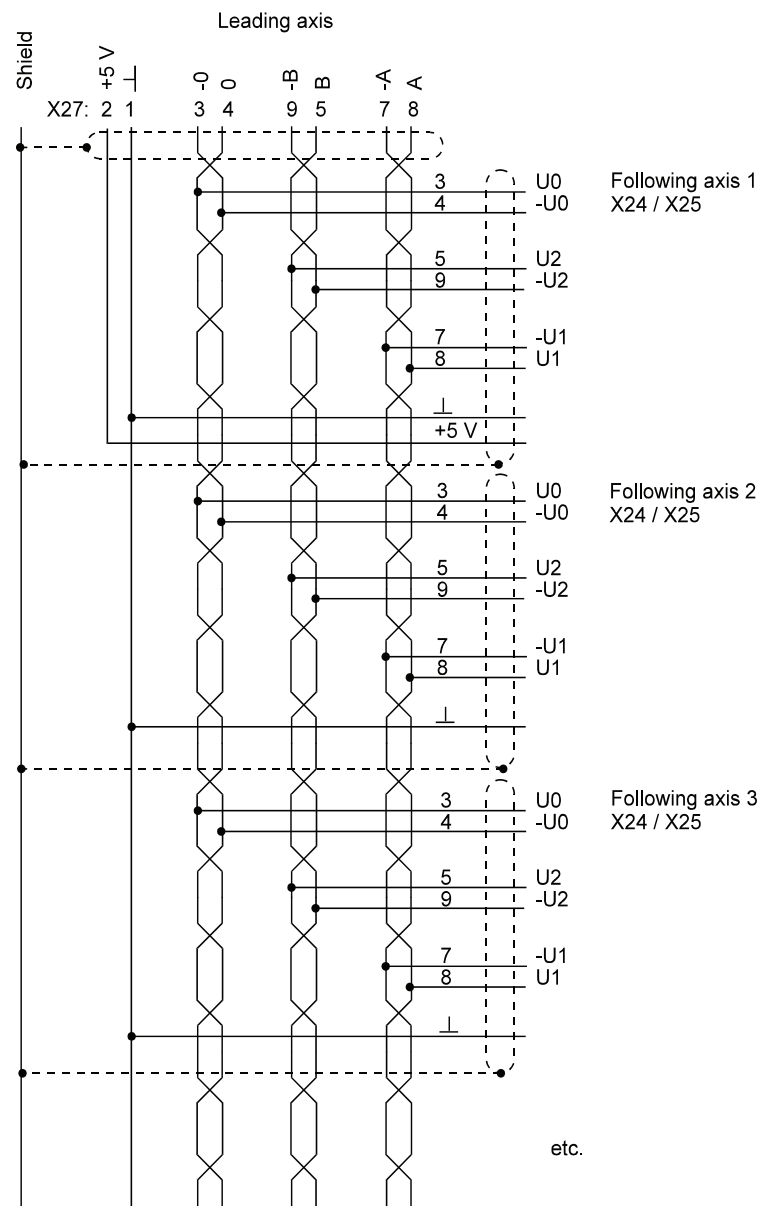

5.8 Accessories

	Part no.
• Bus cable X27 A/B RS485	1901 8026
• Interface cable PC (3 m) X23 RS232	1901 8006
• BL encoder cable 12/15 pin. (cable length on request) X24/X25 Encoder	1901 8026
• Sub-unit terminal Phönix X28 motor temperature recording 3-pin RM 5	1901 7596

6 COMMISSIONING

6.1 Danger Information



WARNING

This equipment carries a dangerously high voltage and, depending on the version, may have dangerous rotating parts (fans). Ignoring the safety and warning information may result in death, severe personal injury or damage to property.

You are responsible for mounting the power converter, the motor, the commutating reactor and any other equipment in accordance with appropriate safety regulations (e.g. DIN, VDE); equally, you must ensure that all other relevant national and local regulations are met with regard to cable ratings and protection, grounding, disconnecters, overcurrent protection, etc.

The most important factors for protecting people are the DIN/VDE protective measures and safety regulations. If there are no protective earth connections on the equipment, commutating reactor or the motor, personal injuries are inevitable, since the surfaces may carry dangerously high voltages.

The power converter's power cables are energized!

The mains unit and the field connector of the power converter carry a dangerous voltage even when the main contactor has dropped.

During operation, the principles on which the power converter and the motor work lead to leakage currents to earth that are dissipated via the specified protective earths and may result in a current-operated e.l.c.b on the input side blowing prematurely.

In the case of a short-circuit to frame or to ground, a direct proportion may arise in the leakage current that makes triggering a higher level current-operated e.l.c.b either more difficult or totally impossible.

Make the PE connection in accordance with DIN EN 60204/VDE 0113 Part 1/06.93; Section 8.2.2 taking into account provisional standard EN 50178/ VDE 0160/11.94, Sections 5.3.2.1 and 8.3.4.4.

Before carrying out commissioning, check whether the plastic covers over the power stage connections are in place.



WARNING

You must only reset the converter when the controller is inhibited and the motor is at a standstill.

If an error occurs, the drive is deenergized and then coasts unbraked to a standstill. You should consider this situation particularly with motion and lifting drives.

Faulty drive response

During initial commissioning, faulty or uncontrolled motion of the driven machine elements is always possible. At this stage, you should therefore proceed with particular care.

Before switching on the drive, you must carefully check the functions of all the higher level safety equipment to prevent injury to people.

Take particular care when directly or indirectly touching the drive shaft with your hand. This is only allowed when the shaft is stationary and the power converter is deenergized. Any exposed parts of the machine, such as the shafts, fans, etc., must be covered during operation.

Contact protection in accordance with paragraph 4 Section 4 VBG 4

Protection against direct contact comprises all the measures against danger that can result from touching the active parts of electrical equipment.

You must therefore protect the active parts from being touched by means of insulation, the construction and arrangement of the equipment or permanently mounted guards. The guards in question are standard covers, barriers and procedures that guarantee that people cannot touch active parts that are carrying power.

Switching cabinets must have an emergency off facility to switch off any voltages that could be dangerous. This does not include equipment which, if switched off, would cause an even more dangerous situation. The emergency off releasing element must be arranged in such a way that it can be reached quickly in case of danger. In the case of work that is considerably more dangerous than usual, another person must be present.

The machine minder must ensure that unauthorized people do not work at the machine.



WARNING

The machine minder must report immediately any changes that occur at the machine which adversely affect safety.

When dismantling safety equipment during commissioning, repair and maintenance work, you must ensure that the machine is taken out of commission in accordance with applicable regulations. You must remount and check safety equipment immediately after completing commissioning, repair and maintenance work.

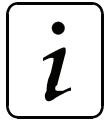

NOTE

Observe electrostatic discharge protection: Before touching the plug, discharge electrostatic energy from your body by touching a grounded conductive object, for example.



6.2 Initial Commissioning of V-Controller

Installation of Operator Programs (see also the respective additional description)

- **WinBASS (2 floppy disks)**

Requirements:

- Windows 3.1 or higher
- 4 MB of RAM (8 MB recommended)
- 10 MB of hard disk space
- 2 installation floppy disks

Procedure

- Boot the PC or laptop
(with a laptop, turn off power management)
- Start Windows
- Insert the installation floppy disk 1 in drive A:
- In the File menu, choose item Run
- Type in "a:\setup.exe" and click on OK
- Check the settings in the setup program and click on "Installieren"

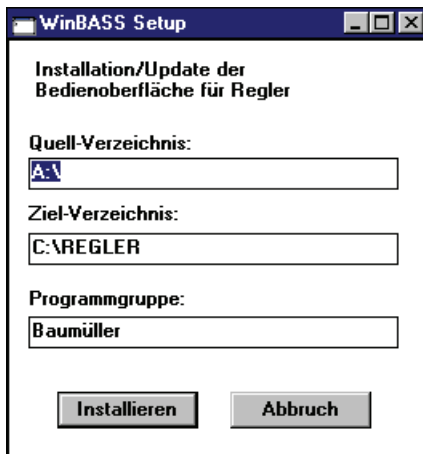

- With Windows 95 only
Close the DOS box when unpacking a file is completed
- Follow the instructions for changing disks
- All the files are copied to the target directory
- The system creates a program group containing Win-BASS
in the case of an update, leave the program group field blank
- Installation is completed
- Call the program using the icon in the Program Manager

- **UPDOWN/PCBASS (1 floppy disk)**

Requirements:

- MS-DOS 3.3 or higher
- 500 kB of DOS memory
- 1 MB
- 1 installation floppy disk

Procedure

- Boot the PC or laptop
- Insert the installation floppy disk in drive A:
- Make a target directory
(e.g. PCBASS)
- Copy all the files to the target directory
- Call the program under DOS
by means of \..\udl.bat

Conditions

- Make a note of the controller type code (refer to the controller rating plate) and the motor article number (refer to the motor rating plate)
- Install the power unit and the motors in accordance with the connection plans (see also the power unit description), e.g. BUG/BUS system

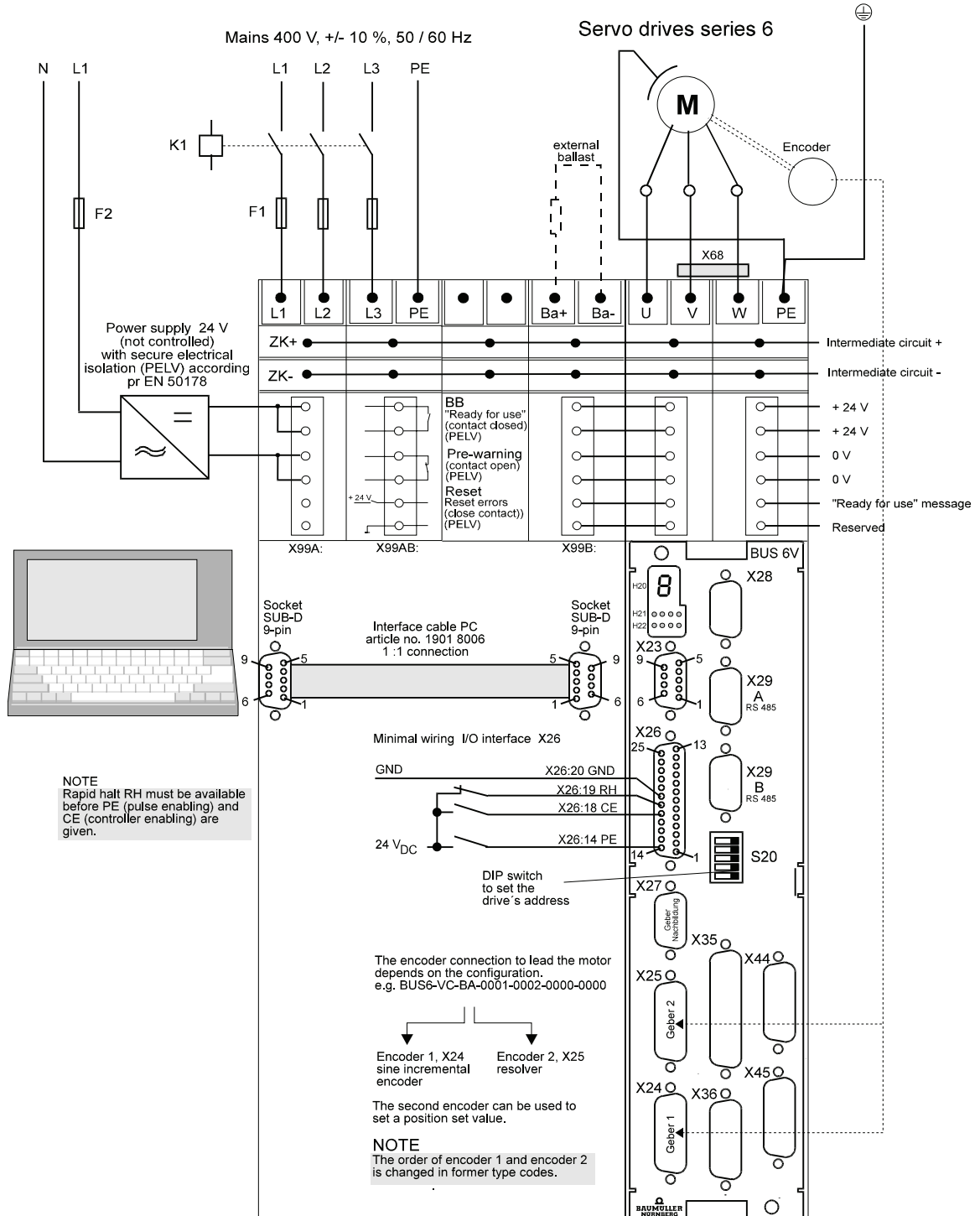

Commissioning

Basic Settings



NOTE

The settings are explained in prompted commissioning under WinBASS. For PCBASS refer to the appropriate inputs.

WinBASS

PCBASS

- **Preparation:**
 - Start WinBASS by means of the Program Manager Icon
 - In the Drive menu, choose item Commissioning
- **Preparation:**
 - Under DOS: in directory PCBASS type in "udl.exe" to start the UPDOWN program

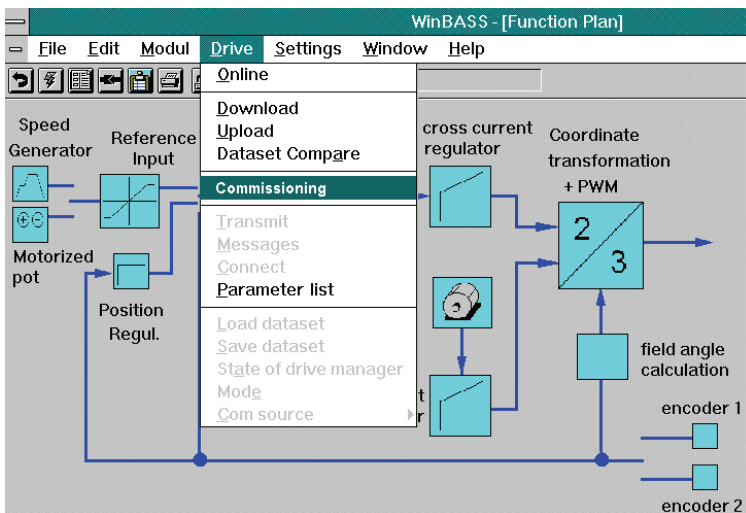

- A help window containing explanatory texts guides you through the commissioning process.
- You can go to the next input screen form or to the previous one by clicking on the respective pushbuttons.

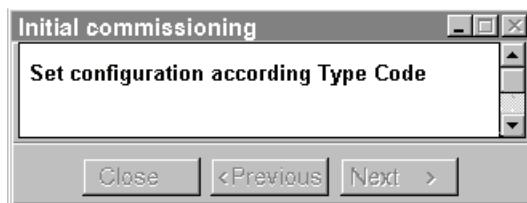

WinBASS

- **System Prompts you for Configuration:**

You can either enter the controller type code and the motor article number or choose them in the Set menu

Is only set if optimized controller parameters are available in addition to the motor data set

- Entering the configuration determines the values of the configuration-dependent parameters.

- **Setting the Operating Mode**

Choose the operating mode for basic setting

Write the settings to the controller's RAM

The system initializes the controller with default values. Do not choose this setting if there is already an executable data set in the controller

The system sets the configuration-dependent parameters. Do not choose this setting if there is already an executable data set in the controller

Go back to configuration setting

Go on to next input screen form

PCBASS

- **Load Default Values:**

Default setting (see parameter overview) means:

- All monitoring facilities are active
- No linkages of inputs and outputs
- Standard motor data
- Encoder modules are deactivated
- Standard values of controller parameters

Procedure:

- Choose Download
- Execute using file "liefer.udl"
- Click on PCBASS
- Choose data set **v_inbetr.dat**

- **Setting the Operating Mode**

- Set in PCBASS online mode by pressing \hat{o}
- Set parameter P126 M communications source to '1'
- Set parameter P122 M operating mode to '-3'
→ speed control

WinBASS

PCBASS

- The system checks the configuration

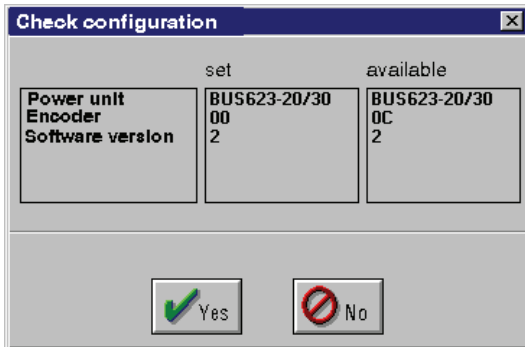

- The system loads parameter values
- Click on OK to acknowledge the messages that the system displays after initialization.
- The system displays the configuration

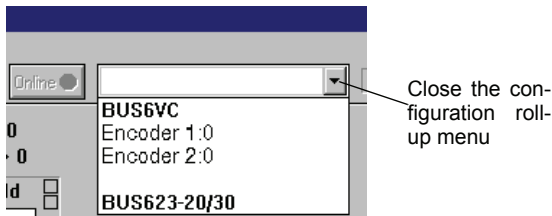

Display of the configuration-dependent motor and power unit parameters:

Overload monitoring with I²T model, e.g. 0 = monitoring off
 Default values: AM: 4 SM: 3
 Differentiation between motor models SM: 0 AM: refer to rating plate

BUG/BUM: 540 V
 BUC/BKH: 640 V

Values relevant with AM only
 Refer to rating plate

Entering motor and power unit parameters:

You must enter or check the values of the following parameters in PCBASS (page 2 of PCBASS: jump to the page number by pressing ¶|2)

For setting information, refer to the respective parameter descriptions

- P260 MM Magn. current ID
- P019 GM Maximum speed
- P261 MM Motor rated current
- P116 LT I lim
- P268 MM Ke factor
- P033 number of motor pole pairs
- P089 I²t time const. motor
- P007 ES rated UZK
- P262 MM rated speed
- P263 MM rated frequency
- Save motor and power unit parameters
- P190 = 0
- P190 = 5

WinBASS

PCBASS

- **Display of setting of encoder evaluation 1 and 2:**

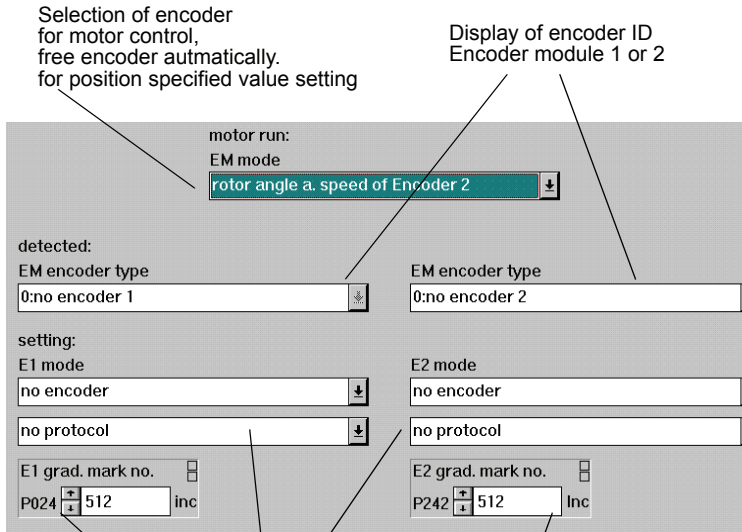

Selection of encoder for motor control, free encoder automatically for position specified value setting

Display of encoder ID Encoder module 1 or 2

Setting of encoder type for encoder 1 or 2

Number of encoder increments
 Resolver: 16,384 incs.
 SCS/SCM 70: 512 incs.
 Incr. encoder: encoder-dependent

- After you choose the encoder for motor control, the remaining encoder module is deactivated.

- **Display of locating angle**

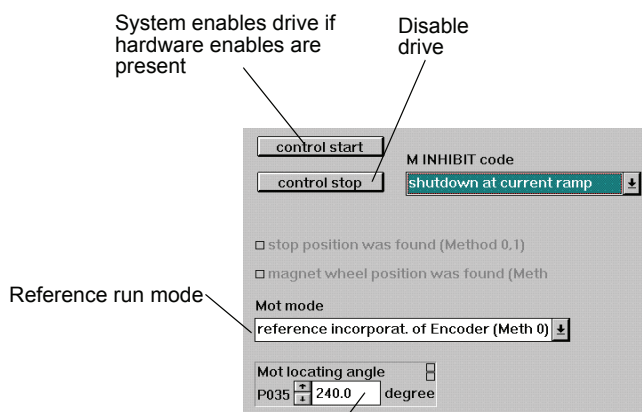

System enables drive if hardware enables are present

Disable drive

Reference run mode

Locating angle:
 240° with Sincos encoder
 150° with resolver

- **Entering encoder parameters**

You must enter or check the values of the following parameters in PCBASS (page 3 of PCBASS: jump to the page number by pressing ¶|3)

For setting information, refer to the respective parameter descriptions

- P040 G1 mode
- P024 G1 no. of increments
- P241 G2 mode
- P242 G2 no. of increments
- Save encoder parameters
 P190 = 0
 P190 = 5

WinBASS

- **Procedure**
Locating angle reference point setting
(see also 6.3 Locating angle reference point setting)
- Specifying the locating angle with resolvers (A) and absolute encoders (C)
 - Choosing the reference run mode
Method 0:
The drive must be mechanically decoupled, and rotate into the locating position.
Method 1:
The drive must not be decoupled but must be able to rotate approximately two degrees in both directions.
 - Enable the drive: issue the software "Enable" and then the hardware enables.
 - After the system displays "Locating angle found", disable the drive with a pulse enable and choose "Control stop" in the program.
- Specifying the rotor position with incremental encoders (B, E)
 - Choosing the reference run mode
Method 2:
The drive must not be decoupled but must be able to rotate approximately two degrees in both directions.
 - Enable the drive: issue the software "Enable" and then the hardware enables.
 - After the system displays "Rotor position found", disable the drive with a pulse enable and choose "Control stop" in the program.

PCBASS

- **Procedure**
Locating angle reference point setting
 - P120 = 0
(M control word, inhibit voltage)
 - P122 = -1
(M set mode, reference locating angle)
 - P031 = 0, 1, 2
(Mot Mode, choose method 0, 1, 2)
 - P120 = 6
(M control word, shutdown)
 - P120 = 7
(M control word, switch on)
 - P120 = 15
(M control word, enable operation)
 - Activate hardware enables
 - Display locating angle found
P036 = 001x,
Display rotor position found
P036 = 002x
 - Deactivate "Pulse enabling" and inhibit voltage with P120 = 0
 - Save locating angle
P190 = 0
P190 = 5

Speed Control:

WinBASS

PCBASS

- **Default speed control settings – without analog input –**

Drive enable:
Drive is enabled when the hardware enable is pending

Inhibit drive

Speed controller
Gain: 10
Int. action time: 25 ms

Current controller
Gain: 1
Int. action time: 2.5 ms

Specified value setting
100% = Motor rated speed

Display of various specified and actual values

The stated values for the speed and current controllers are default values, optimization is ignored here

If parameter P002 is logically operated (highlighted in colour), remove the logical operation first:

- Choose parameter P002 by double-clicking on it

Choose connection

Choose Disconnect

- **Speed control**

You must enter or check the values of the following parameters in PCBASS (page 4 of PCBASS: jump to the page number by pressing ¶|4)

- P002 = 30%, for example
Set a speed specified value
- P122 = -3
(M spec. mode speed control)
- P013 = 1 (input 1)
(ramp function generator mode, input 1)
- Software enable by entering one after the other
P120 = 0
P120 = 6
P120 = 7
P120 = 15
- Activate hardware enable, pulse enabling
- Drive rotates at specified speed: use P051 to check speed actual value
- You can use P002 to change the speed
- Inhibit the drive: first deactivate controller enabling and then pulse enabling (drive brakes to a standstill)
P120 = 0

Ending Commissioning

WinBASS

PCBASS

You should commission the motor speed-controlled by means of digital specified value setting via ramp function generator input 1:

- Define a speed specified value using P002, ramp function generator input 1
- First issue the software "Control start", then the hardware enables
- The drive turns at the specified speed, check the speed actual value using P051
- You can change the speed using the speed specification
- With inhibit drive, First deactivate the controller enable, then deactivate pulse enable (the drive brakes to a standstill) and choose "Inhibit" in the program.

• Saving the boot data set

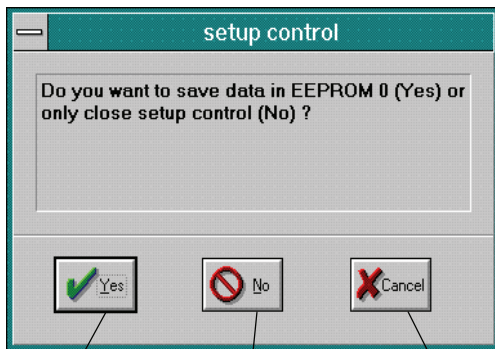

The system saves the determined parameters in the controller as the boot data set

The system doesn't save the determined parameters in the controller as the boot data set

Go back to last screen

• Saving the boot data set

You must enter the values of the following parameters in PCBASS P126

The communications source must be set to the active one.

- P190 = 0 (DSM command reset)
- P193 = 0 (DSM DS Name, boot data set)
- P190 = 5 (DSM command save DS)
- P191 = 3 (DSM status, DSs were saved without errors)

• Data set management

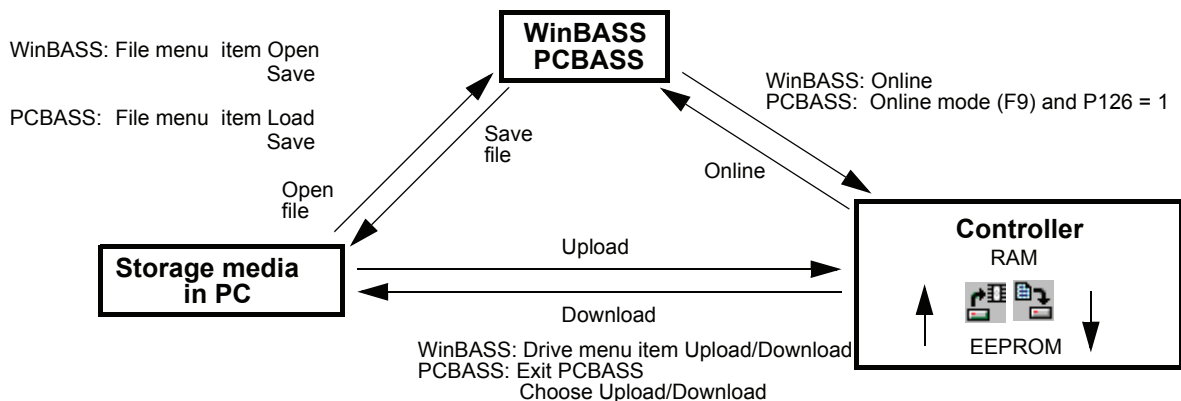

Speed control by means of analog input 1:



NOTE

Commissioning has been carried out and motor and encoder setting has been completed.

- **Extending the wiring of X26**

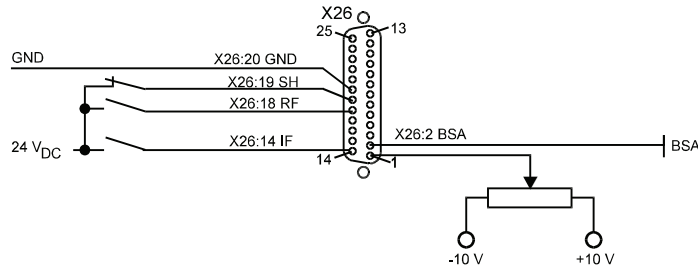

WinBASS

PCBASS

- Choose the Drive Manager from "Modules" via communications
 - Establish controller to PC communications by means of Comm. source: BASS protocol RS232

- Load BUS6VC02.dat

- Establish controller to PC communications as follows:

- press \hat{o} to start online operation
- P126 = 1
Comm-source: BASS protocol.

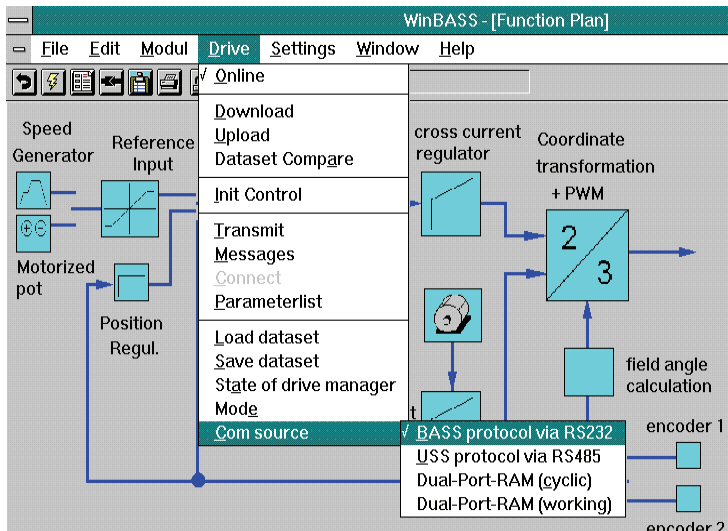

WinBASS

PCBASS

- Click on the ramp function generator in the control system flowchart or choose ramp function generator from "Modules" via controller

Set the speed control n operating mode

NOTE

The system doesn't accept the operating mode setting until you close the roll-up menu

Set the input selection to input 1:

- Input in ramp function generator mode = 1
- Click on switch and place it in desired setting

Open the links window

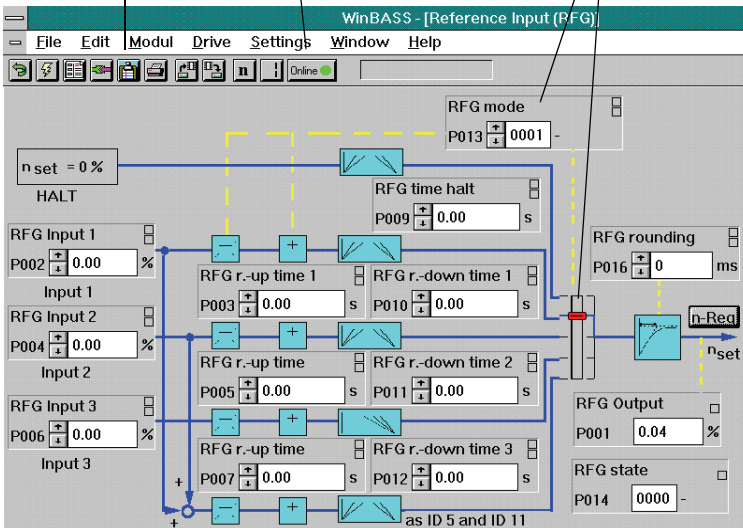

- P122 = -3
Mode
Speed control
- P013 = 1
Input selection of input 1 (P002)

- Open the links window

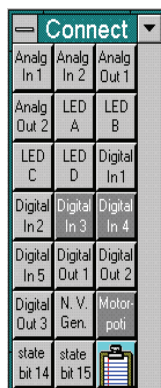

- P280 = 2
Link analog input 1 to the ramp function generator's input 1 (P002).

- Click on analog input 1 and link it to P002.
- The system displays the logical operation in the ramp function generator by highlighting parameter P002 in colour

WinBASS

PCBASS

- After logically operating a parameter, the system automatically opens the analog input 1 module (AE1)

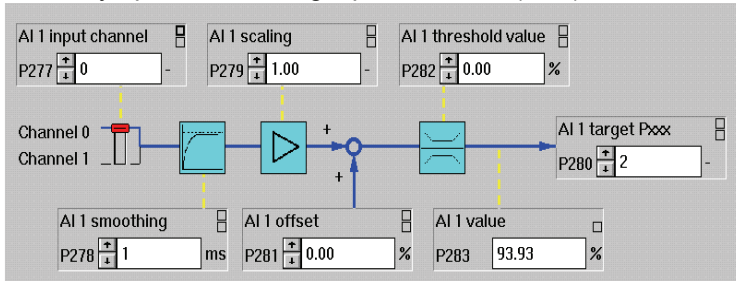

- The input channel must be set to 0; otherwise, you must change the wiring.
- Smoothing 1, scaling 1, offset 0 and threshold value 0 have the following meanings:
 - 10 V ↔ rated speed
 - 0 V ↔ standstill
 - 10 V ↔ negative rated speed
- Close the "Analog input 1" window
- Activate hardware enables
- Enable the controller in software

Save data set in the controller

Mark status 4 and accept it by closing the roll-up menu

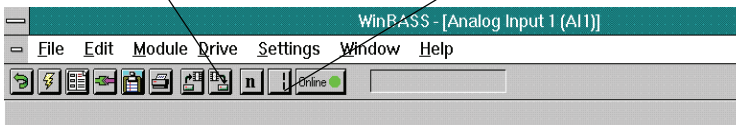

- Motor turns according to specification of potentiometers

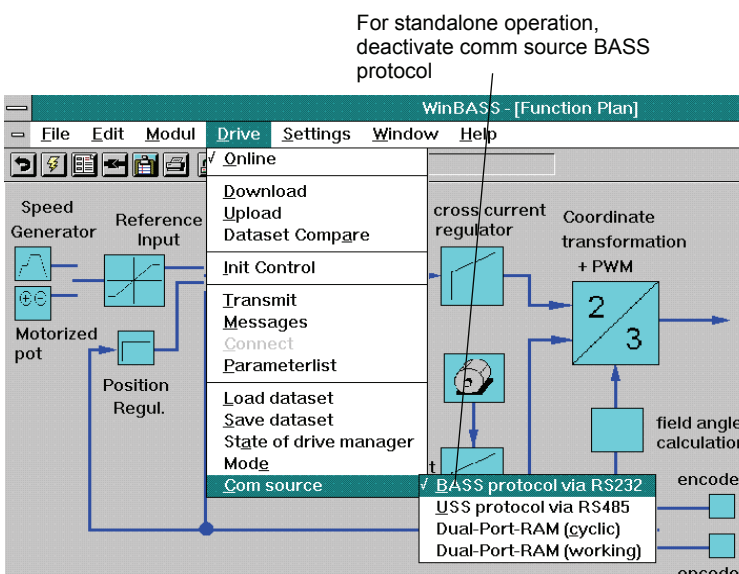

For standalone operation, deactivate comm source BASS protocol

- Check the additional settings of the analog input:
 - P278 = 1
AE 1 smoothing
 - P279 = 1
AE 1 scaling
 - P281 = 0
AE 1 offset
 - P282 = 0
AE1 threshold value
- 10 V ↔ rated speed
- 0 V ↔ standstill
- 10 V ↔ negative rated speed
- Software enable by entering one after the other
 - P120 = 0
 - P120 = 6
 - P120 = 7
 - P120 = 15
- Activate hardware enable, pulse enabling

- Motor turns according to specification of potentiometer

- P160 = 0
You can only choose standalone operation via hardware inputs
- P190 = 0
(DSM Reset command)
- P190 = 5
(DSM command Save DS)

6.3 Locating Position Reference Point Setting

If you do not know the encoder's installation position, you must carry out reference point setting

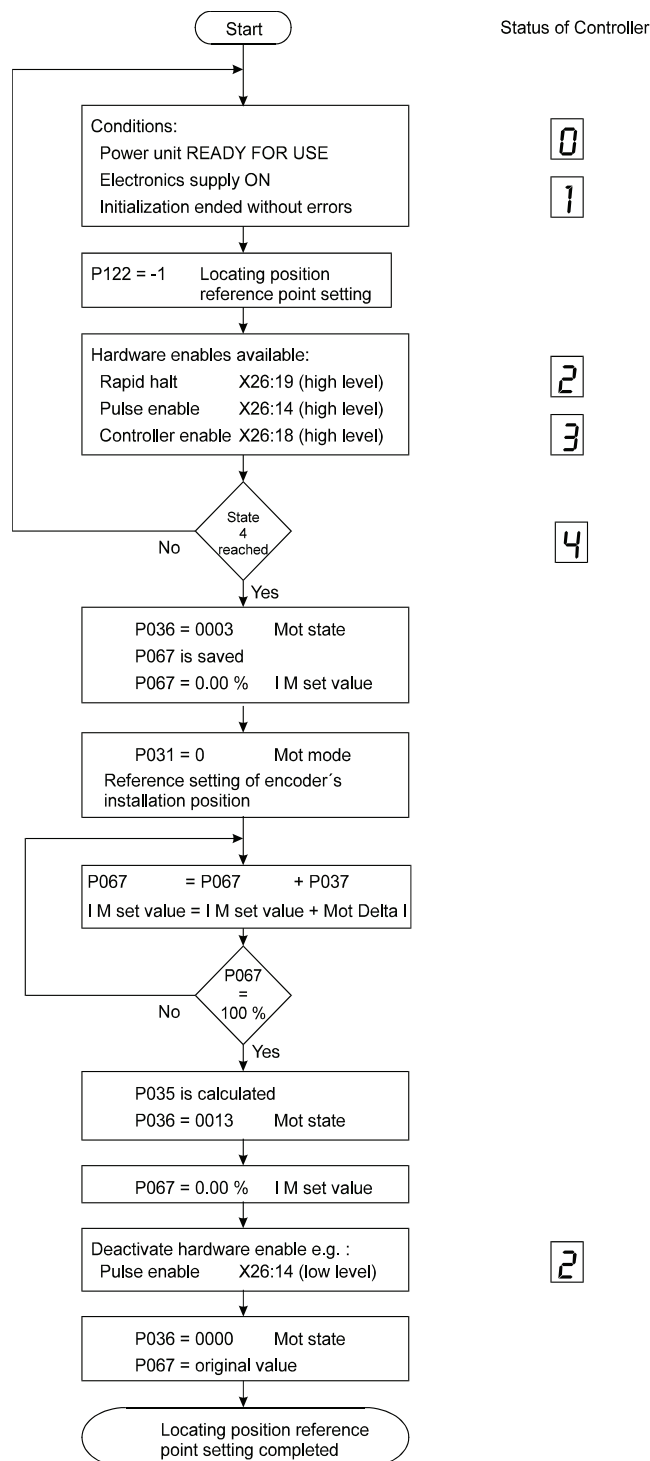

6.4 Commands to Start the Drive

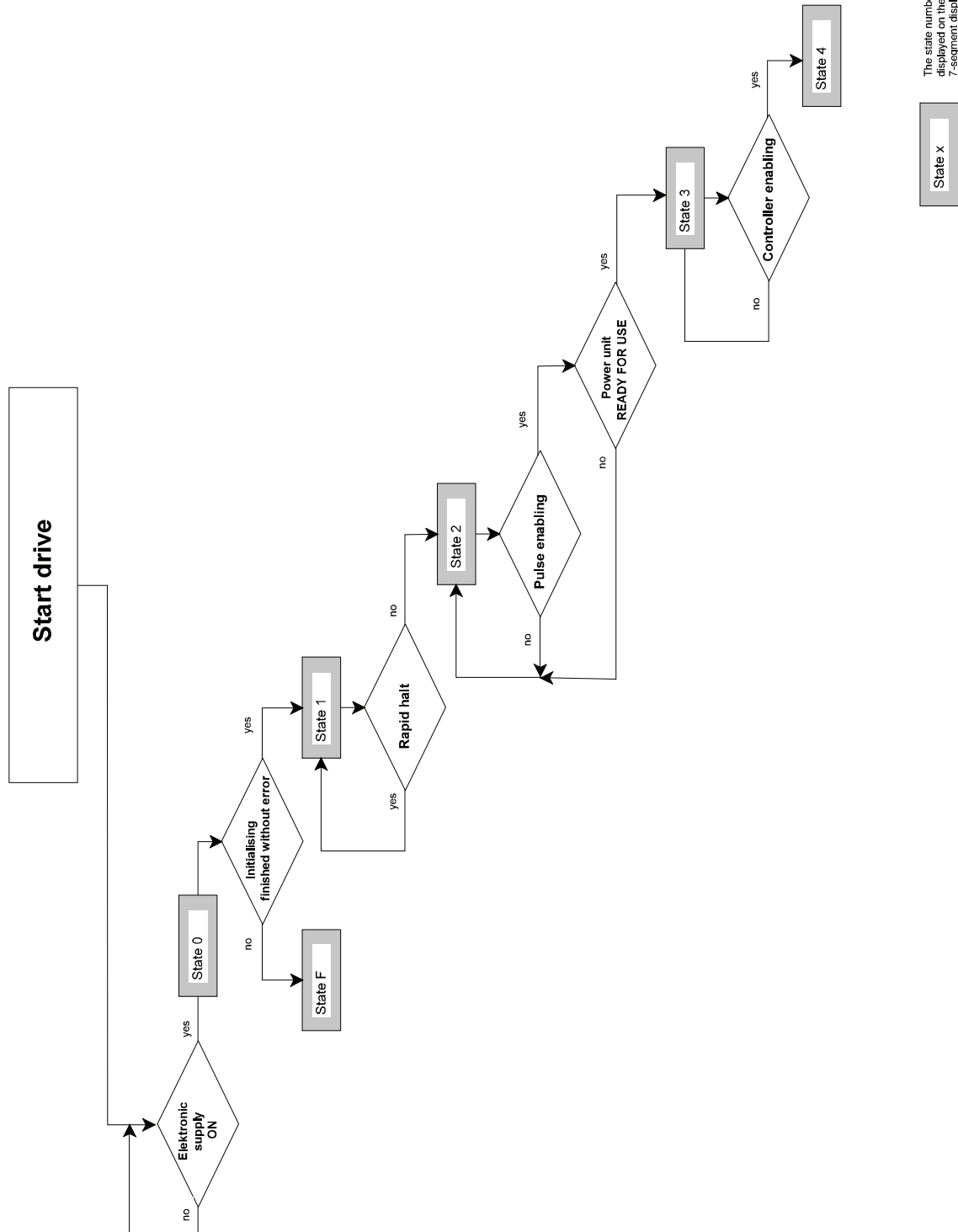

6.5 Commands to Stop the Drive

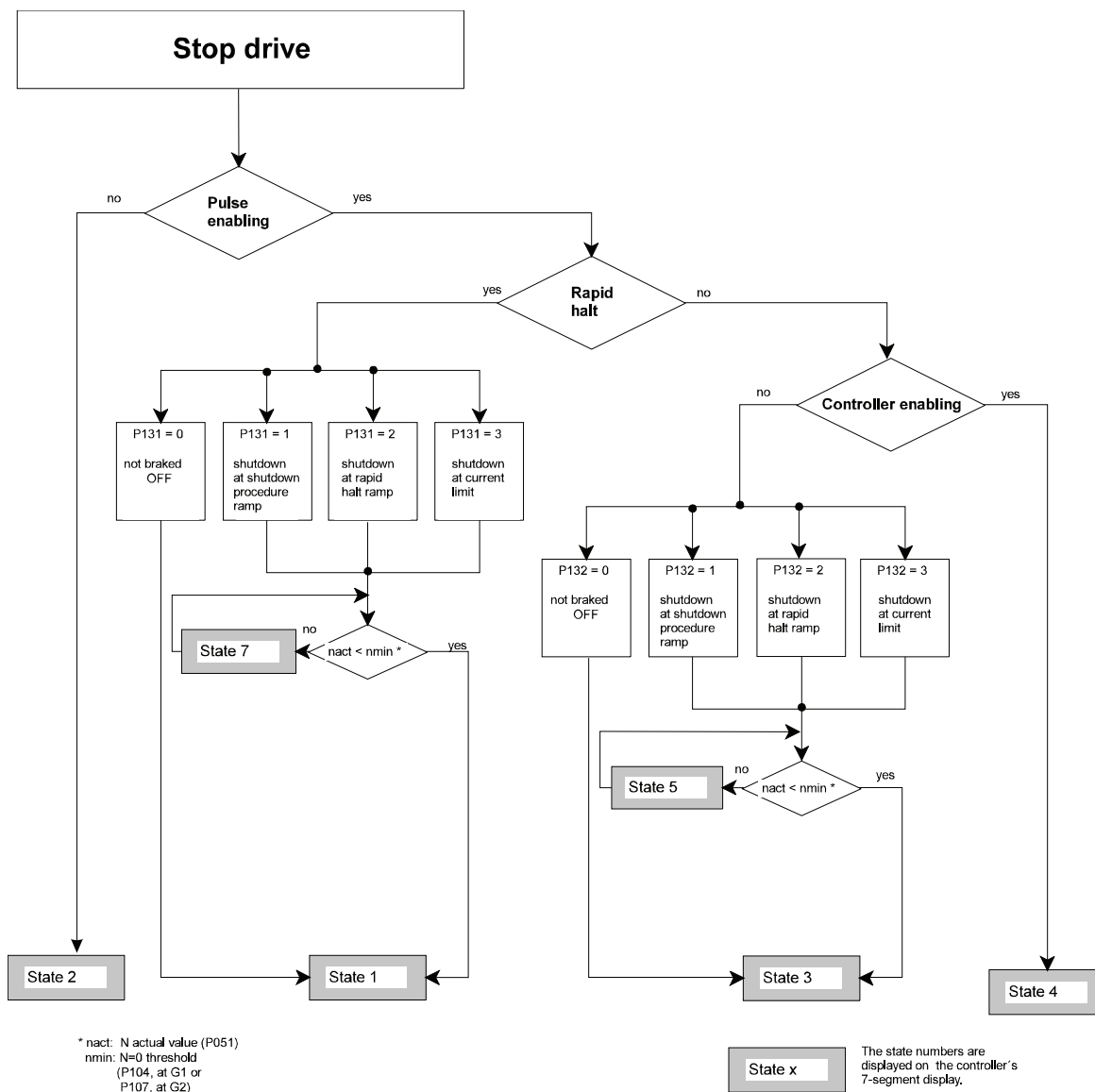

7 PARAMETER

7.1 Function Diagrams

Encoder Evaluation

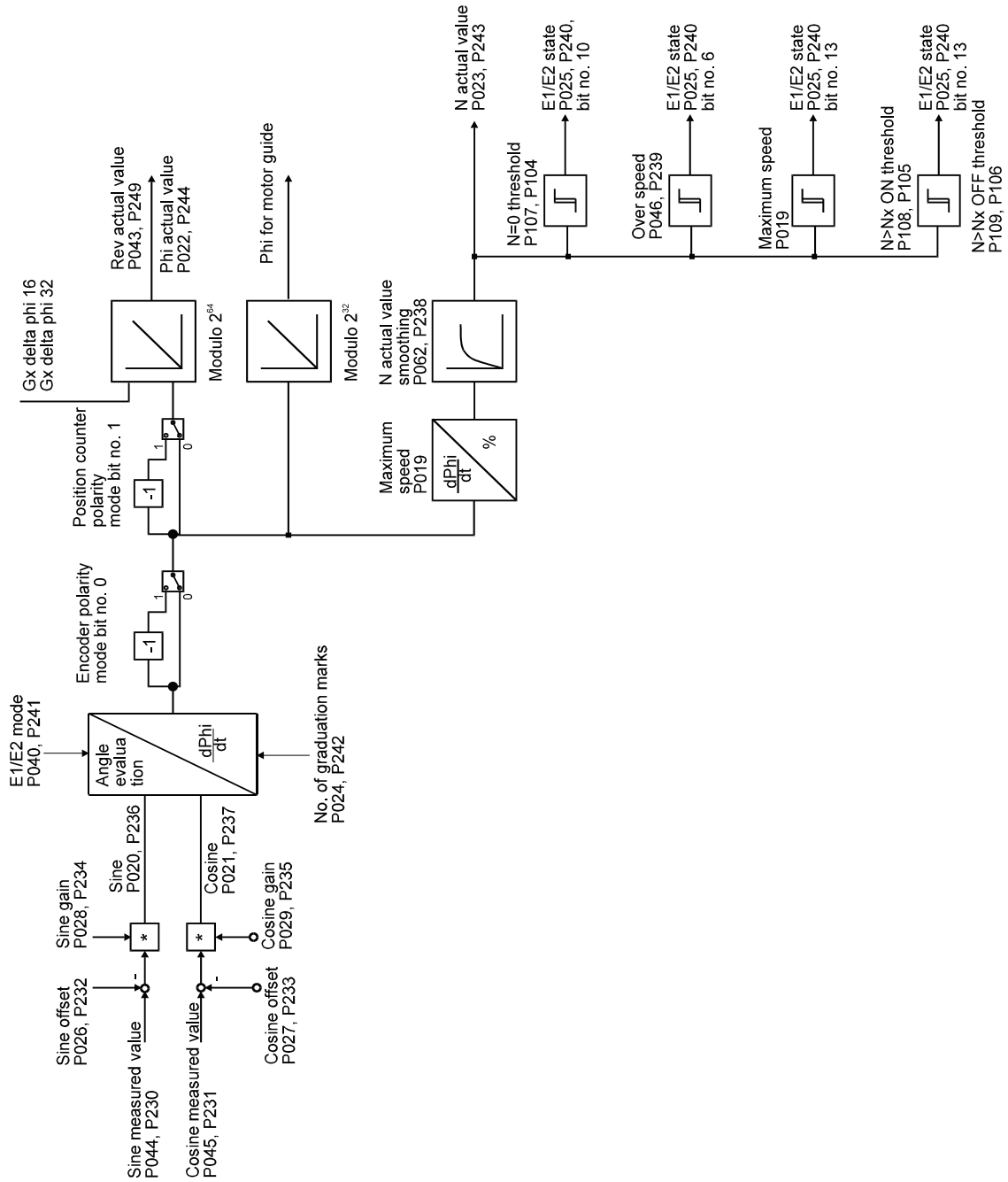

Overview V-Controller

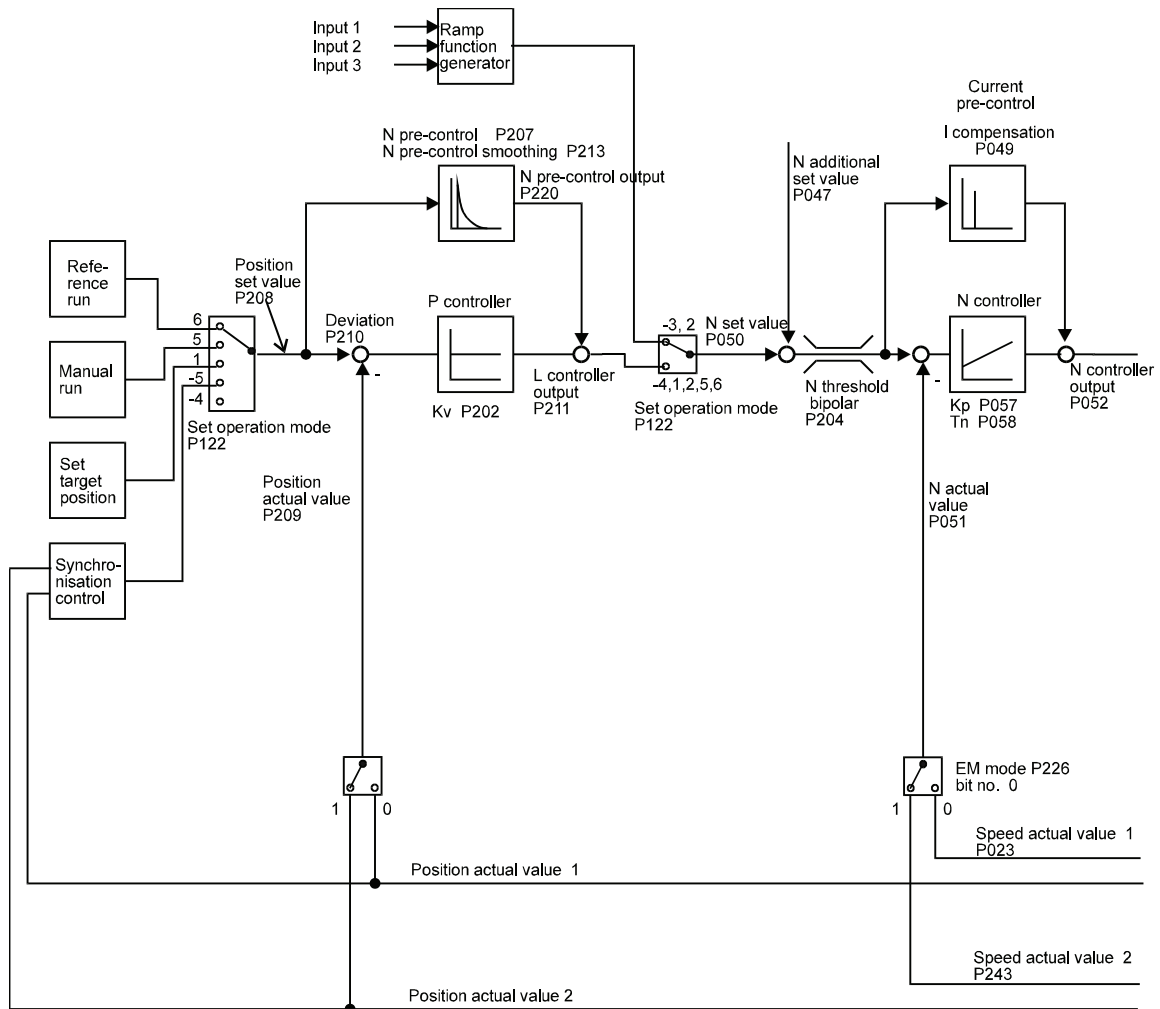

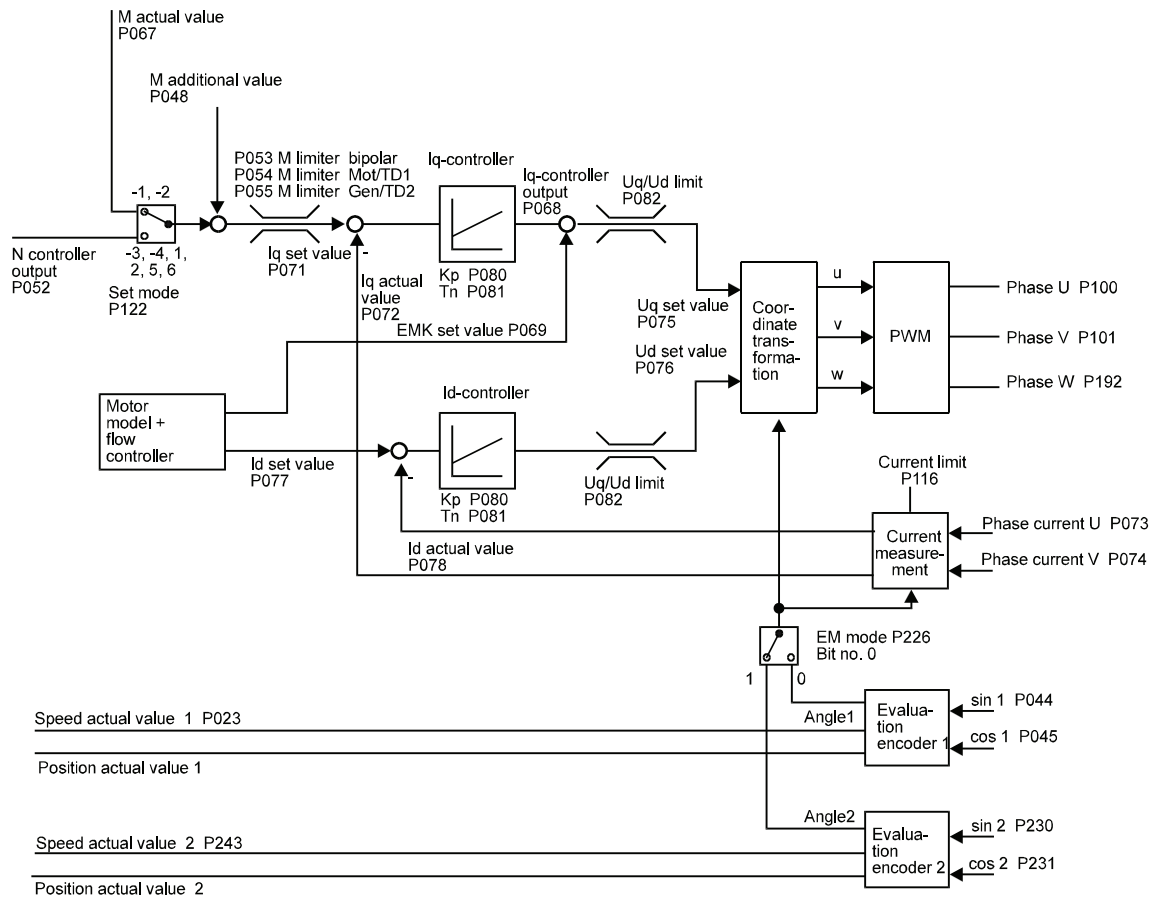

Current Measurement and Monitoring

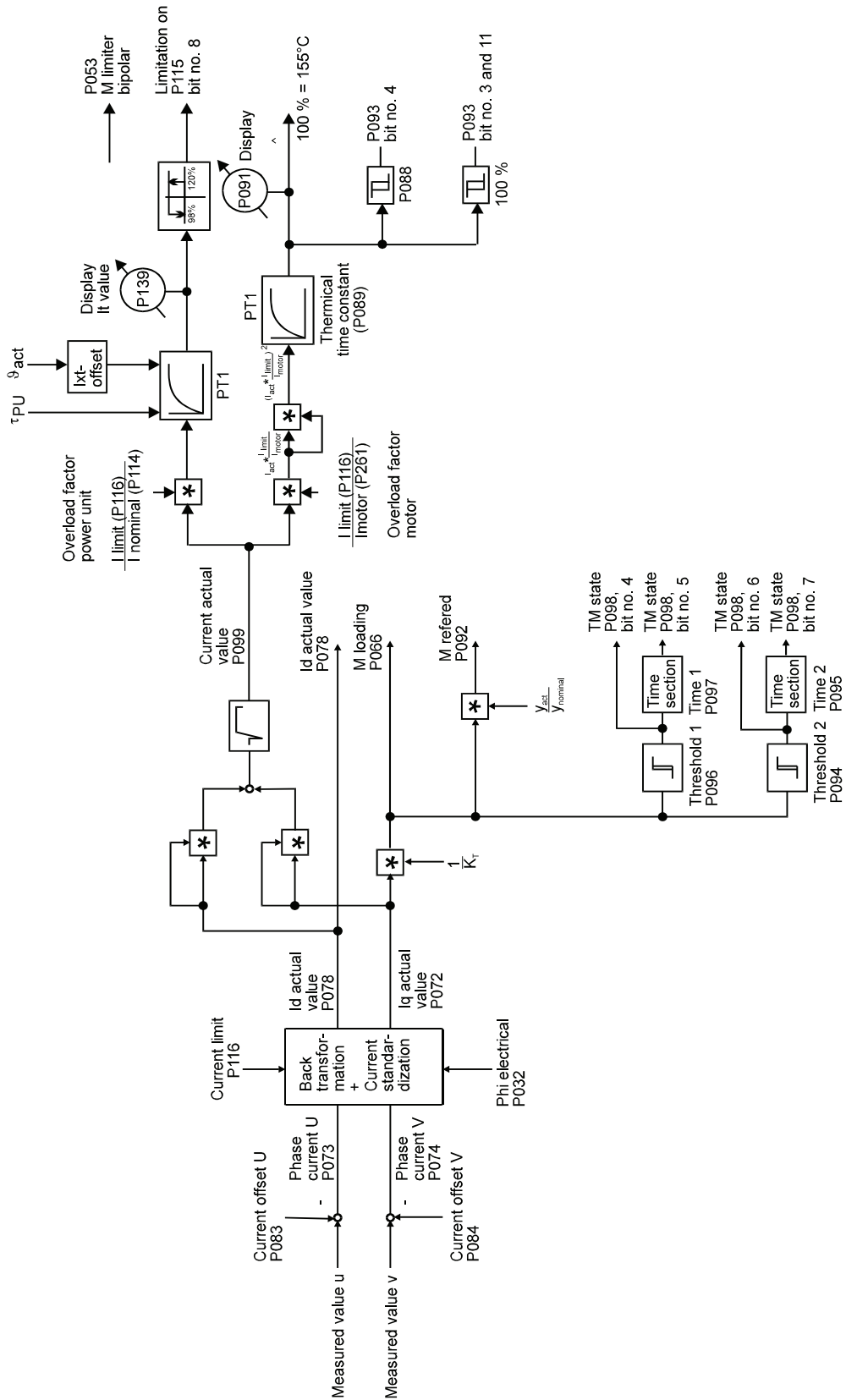

7.2 Power Supply

Function

The function module indicates the status of the power supply unit and the intermediate circuit. Moreover the function voltage failure compensation and intermediate circuit monitoring is implemented.

Parameter description

Parameter	Name	Range min. ... max.	Unit	Display only
P110	PS state	0000 ... FFFF		×
P087	PS U_{ZK} nominal	280 ... 1000	V	
P111	PS voltage U_{zk}	97 ... 1000	V	×
P112	PS voltage failure time	0 ... 6	s	

Parameter description

P 110 PS state

This parameter indicates the present power supply state.

Bit no.	Meaning
0 ... 2	0 : STOP Ready for use signal power supply is not monitored 1 : RUN Ready for use signal power supply is monitored 3: STAND BY State after status transition 3 in drive manager. The time to load the intermediate circuit is considered. After maximal 10 s the ready for use signal of the power supply must be available, otherwise the fault 0110 is created.
3	1 : Fault in function module, fault code see M fault code (P124)
4	1 : Main contactor is on
5	1 : Warning voltage failure
6	1 : Ready for use signal of power supply is available
7 ... 15	reserved

P 087 PS U_{zk} nominal

This parameter sets the nominal intermediate circuit voltage of the power unit.

$$U_{ZK} = U_{Mains} \cdot \sqrt{2}$$

U_{Mains} : voltage between lines

P 111 PS voltage U_{zk}

This parameter displays the actual intermediate voltage in V.

P 112 PS voltage failure time

Within this time an automatic restart of the drive after a voltage failure is possible.

Value	Meaning
= 0	automatic start not possible
> 0	automatic start possible

For a voltage failure the following sequence will arise:

The voltage failure is acknowledged by the power supply unit and its disabled status is relayed to the controller by means of the ready for use signal.

The function module power supply recognises this and relays it via bit no. 5 = 1 (warning voltage failure) to the drive manager, and starts a timer, set with the aforementioned time.

The drive manager changes from the status OPERATION ENABLED to the status SWITCHED ON, whereby the method by which this is achieved (see function module drive manager) is set via the parameter M INHIBIT code (P132).

The drive manager remains in the state READY TO START until:

either

the set voltage failure time has expired. After which the function module power supply registers a fault and the drive manager changes to the status FAULT.

or:

the main voltage returns before the end of the voltage failure time. If this occurs the power supply unit resets the signal ready for use (see documentation on power supply unit). The function module power supply acknowledges the new status and reacts by setting bit no. 5 to 0 (warning disabled). The drive manager returns again to the status OPERATION ENABLED and the drive ramps-up automatically.

It is assumed that the controller electronics are supplied with voltage during the voltage failure time!

7.3 Power Unit

Parameter description

Parameter	Name	Range min. ... max.	Unit	Display only
P115	PU state	0000 ... FFFF		×
P090	PU mode	0000 ... 0001		
P117	PU type	0.1 ... 2500.0		×
P114	PU I nominal	0.1 ... 2500.0	A	×
P113	PU I max	0.0 ... 2000.0	A	×
P119	PU overload time	0.00 ... 600.00	s	×
P116	PU I limit	The range depends on the PU. Permitted range: $\frac{LT \cdot I_{nom}}{4} \leq \text{PU I limit} \leq \text{PU I max}$	A	
P118	PU temperature	-80 ... 130	°C	×
P139	PU lxt value	0.00 ... 200.00	%	×

Parameter description

P115 PU state

This parameter displays the state of the power unit.

Bit no.	Meaning
0 ... 2	0 : STOP 1 : RUN
3	1 : Error in function module, error code see M error code (P124)
4	1 : Power unit reset is active
5	1 : Pulses are enabled, power unit is active
6	1 : Power unit temperature > 80 °C
7	1 : Power unit ready for use
8	1 : PU monitoring is active, current reduction to 100% I_{nom} power unit
9 ... 15	reserved

P090 PU mode

The parameters P114, P113 and P119 can only be changed, if PU Mode 0001_{hex} and the password is correct..

Bit no.	Meaning
0	0 : Read the power unit's characterisation, data is set according to the characterisation 1 : Characterization is not read, PU data is read from EPROM
1 ... 15	reserved

P 117 PU type

The parameter displays the type of the power unit. The value 0 characterizes an unknown power unit.

Version	Power unit	PWM frequency P103 = 8 kHz nominal/peak current effective	PWM frequency P103 = 4 kHz nominal/peak current effective	Overload time in s
6210	BUS621	5 A / 7.5 A	6.3 A / 7.5 A	1
6211	BUS621	10 A / 15 A	12.5 A / 15 A	1
6212	BUS621	2.5 A / 3.7 A	3.1 A / 3.7 A	1
622	BUS622	14.7 A / 22 A	18.3 A / 22 A	1
623	BUS623	20 A / 30 A	25 A / 30 A	1
6240	BUS624	38 A / 57 A	47.5 A / 57 A	1
6241	BUS624	45 A / 67.5 A	56.3 A / 67.5 A	1
600	BUM60	12 A / 24 A	15 A / 24 A	1
601	BUM60	6 A / 12 A	7.5 A / 12 A	1
602	BUM60	3 A / 6 A	3.7 A / 6 A	1
62	BUM62	57.7 A / 75 A	75 A / 97.5 A	120
6201	BKH62	75 A / 97.5 A	90 A / 97.5 A	1
63	BUM63	115 A / 150 A	150 A / 195 A	120
6301	BKH63	150 A / 195 A	180 A / 195 A	1
64	BUM64	231 A / 300 A	300 A / 390 A	120

How to change the power unit data, see below:

PU mode = 0001_{hex} P090

DSM command = 0 P190

DSM command = 8 P190

Enter password 1

Parameter P013, P114 and P119 can now be set and the PU characterization is not be read at booting.

Values for peak current (P115), nominal current (P114) and overload time (P119) see table above.

PU I max = set table value P113

PU I nominal = set table value P114

PU overload time = set table value P119

PU I limit = set value P116

DSM command = 0 P190

DSM command = 5 P190

→ Values are stored in the EEPROM

The data of the power unit is available now on every switch on.



NOTE

After each change of parameter P103 (PWM) the data must be saved, the controller switched off and booted new to set the new power unit parameters.

P 114 PU I nominal

This parameter displays the power unit's nominal current. This current can be supplied for an unlimited time.

P 113 PU I max

This Parameter shows the power unit's peak current. The peak current is greater or equal power unit nominal current.

P 119 PU overload time

During the overload time the power unit can supply the peak current. After that the nominal current (P114) is limited. The bit no. 8 in PU state (P115) displays the limitation.

P 116 PU I limit

This parameter sets the standardization of the current controlling.

Standardization

$$100 \% \leftrightarrow I \text{ limit}$$

The limits of this parameter depend on the power unit used.

Example: PU type = 6211 ↔ BUS 621 (10 A / 15 A)

P 118 PU temperature

This parameter displays the power unit's temperature.

A temperature over 80°C enables the bit no. 6 in PU state (P115). Exceeds the power unit's temperature 85°C the error 0205_{hex} appears.

P 139 PU Ixt value

This parameter displays the actual I*t value of the overload monitoring. At a value equal 100 % follows a current limitation to nominal current (P114). Drops the I*t value below 95% the current value is set to PU I limit (P116).

Function of the power unit's overload monitoring

This monitoring protects the power unit from thermic overload. The temperature of the power unit is imitated and monitored by a I*t model.

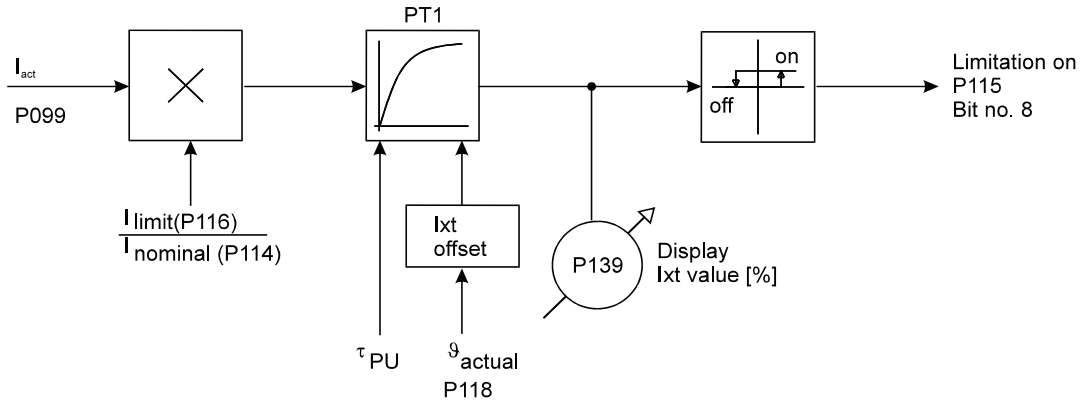

Current set value	(I _{act}) [A _{eff}]	P099
PU nominal current	(I _{nom}) [A _{eff}]	P114
PU maximum current	(I _{max}) [A _{eff}]	P113
PU limit current	(I _{limit}) [A _{eff}]	P116
PU overload time	(t _o) [s]	P119
PU temperature	(θ _{act}) [°C]	P118
PU Ixt value	(Ixt) [%]	P139
PU overload factor max	(u _{max}) [%]	
PU overload factor actual	(u) [%]	
PU thermic time constant	(τ _{PU}) [s]	
PU reaction time	(t _{rea}) [s] time till the limitation of I _{nom}	
PU Ixt offset	(Ixt offset) [%]	

$$u_{\max} = \frac{I_{\max}}{I_{\text{nom}}} \cdot 100 \quad [\%]$$

$$u = \frac{I_{\text{act}}}{I_{\text{nom}}} \cdot 100 \quad [\%]$$

$$\tau_{\text{PU}} = -\frac{t_o}{\ln\left(\frac{u_{\max} - 100}{u_{\max}}\right)} \quad [\text{s}]$$

- for power unit temperature > 45 °C

$$I_{xtoffset} = \frac{\vartheta_{act} - 45^{\circ}\text{C}}{85^{\circ}\text{C} - 45^{\circ}\text{C}} \cdot 100 \quad [\%]$$

- otherwise
Ixt offset = 0 %

$$t_{off} = \tau_{PU} \cdot \ln\left(\frac{u - 100}{u - I_{xtoffset}}\right)$$

Example:

$$I_{nom} = 10 A_{eff} \text{ (BUS 621)}$$

$$I_{max} = 15 A_{eff} \text{ (BUS 621)}$$

$$t_u = 1 \text{ [s] (BUS 621)}$$

$$I_{limit} = 12 A_{eff}$$

$$\vartheta_{ist} = 35^{\circ}\text{C}$$

$$u_{max} = \frac{15}{10} \cdot 100 = 150 \quad [\%]$$

$$u = \frac{12}{10} \cdot 100 = 120 \quad [\%]$$

$$\tau_{LT} = -\frac{1}{\ln\left(\frac{150-100}{150}\right)} = -(0,91) \quad [\text{s}]$$

$$t_{aus} = -(0,91) \cdot \ln\left(\frac{120-100}{120-0}\right) = 1,63 \text{ [s]}$$

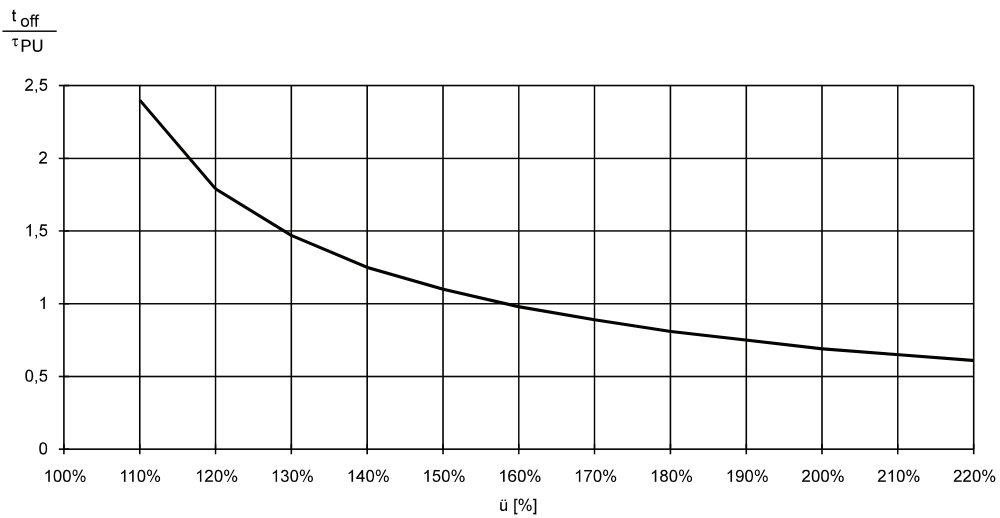
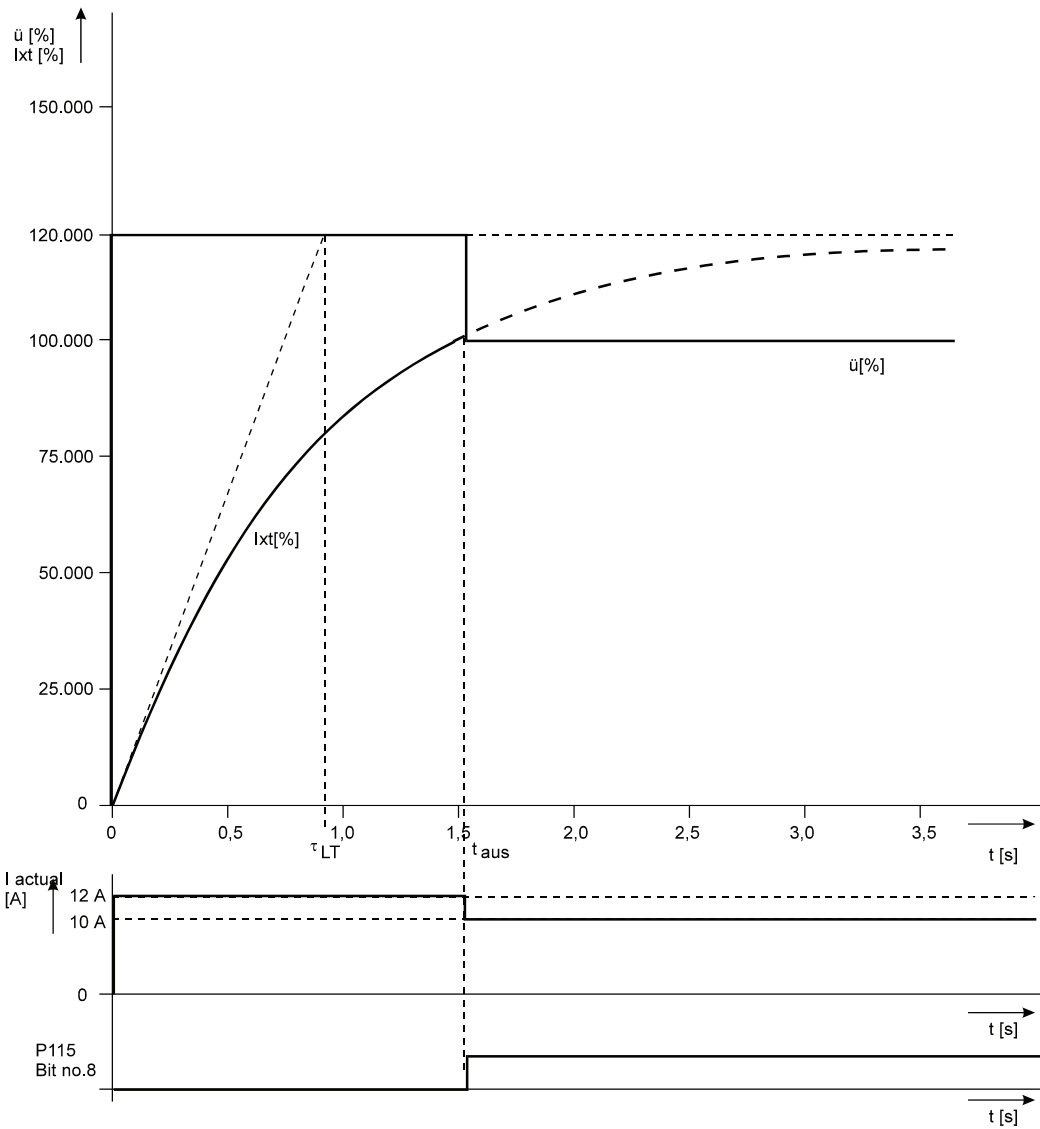

This characteristic curve refers to a „cold“ power unit (l_{xt} Offset = 0%; $\vartheta_{ist} < 45^\circ\text{C}$).

7.4 Pulse Width Modulation

Function

The parameters of the pulse width modulation module only serve to display the values supplied by the current controller.

Parameter overview

Parameter	Name	Range min. ... max.	Unit	Display only
P100	PWM phase U	-100.00 ... +100.00	%	×
P101	PWM phase V	-100.00 ... +100.00	%	×
P102	PWM phase W	-100.00 ... +100.00	%	×
P103	PWM frequency	4.0 ... 8.0	kHz	

Parameter description

P 100 PWM **phase U**

P 101 PWM **phase V**

P 102 PWM **phase W**

These parameters display the angle α of the relative power transistors for the individual phases. The sum of these 3 parameters is always 0.

This means: +100.00 % to a regulation angle of $\alpha = +100 \%$
 0 to a regulation angle of $\alpha = 0 \%$
 -100.00 % to a regulation angle of $\alpha = -100 \%$

The resultant voltage (middle values) at the power supply terminals can be calculated as follows:

$$\overline{U_{UV}} = U_{ZK} \cdot \frac{\text{PWM phase U} - \text{PWM phase V}}{\text{maximum total range}} = P111 \cdot \frac{P100 - P101}{200,00 \%}$$

$$\overline{U_{VW}} = U_{ZK} \cdot \frac{\text{PWM phase V} - \text{PWM phase W}}{\text{maximum total range}} = P111 \cdot \frac{P101 - P102}{200,00 \%}$$

$$\overline{U_{WU}} = U_{ZK} \cdot \frac{\text{PWM phase W} - \text{PWM phase U}}{\text{maximum total range}} = P111 \cdot \frac{P102 - P100}{200,00 \%}$$

Whereby U_{ZK} is the intermediate circuit voltage which is indicated via P111. Due to the underlying cycle frequency this voltage cannot be measured on universal devices.



DANGER

Even with an output voltage close to zero, the pulsed intermediate circuit voltage is detectable at the terminals. In addition a potential of > 300 V to earth may be detected at the terminals.

P 10 3 PWM frequency

The frequency of the power unit is normally 8.0 kHz and can be changed to 4.0 kHz (values between are not possible).

7.5 Motor Model

Function

This function module sets the parameters for synchronous and asynchronous machine.

Parameter overview synchronous machine

Parameter	Name	Range min. ... max.	Unit	Display only
P260	MM magnetizing current I_d	0.0 ... P116	A	
P261	MM motor nominal current	•	A	
P268	MM Ke factor	0 ... 400	V/1000	

Parameter overview asynchronous machine

Parameter	Name	Range min. ... max.	Unit	Display only
P260	MM magnetizing current I_d	0.0 ... P116	A	
P261	MM motor nominal current	•	A	
P268	MM Ke factor	0 ... 400	V/1000	
P264	MM Kp flux controller	0.2 ... 15.9		
P265	MM Tn flux controller	0.0 ... 1000.0	ms	
P293	MM Tr rotor actual value	0 ... 1000	ms	×
P266	MM flux set value	0 ... 100	%	×
P267	MM flux actual value	0 ... 100	%	×
P269	MM mode	0000 ... FFFF		
P262	MM nominal speed	1 ... 11500	rpm	
P294	MM frequency temperature 1	10 ... P263	Hz	
P295	MM temperature 1	-30 ... P296	°C	
P263	MM nominal frequency	P294 ... 600.0	Hz	
P296	MM temperature 2	P295 ... 230	°C	
P297	MM frequency = f (temp)	10.00 ... 600.00	Hz	×
P291	MM MGen1 Nnominal	0 ... 100	%	
P292	MM MGen2 12000 rpm	0 ... P291	%	

- Minimal value = $1/10 \cdot$ nominal current of the power unit
Maximum value = peak current of the power unit (see parameter P117 LT version)

Parameter description for synchronous and asynchronous machines

P 2 6 0 MM magnetizing current I_d

This parameter sets the difference between synchronous and asynchronous machine.

SM: $I_d = 0$

AM: See I_d from motor data sheet

If I_d is not known, it can be calculated approximately

$$I_d = |I_n| \cdot \sqrt{1 - (k \cdot \cos \varphi_n)^2}$$

It is: $|I_n|$ = motor nominal current (P261)

$\cos \varphi_n$ = $\cos \varphi$ motor in nominal load (see type code)

$k = 1.0 \dots 1.3$



NOTE

You must check that the locating angle (P035) is set correctly at switching of asynchronous and synchronous machines.

P 2 6 1 MM motor nominal current

This parameter sets the motor nominal current. Moreover it is used to calculate the overload factor of the motor I^2t monitoring.

$$\text{Overloadfactor} = \frac{\text{Motor nominal current (P261)}}{I_{\text{limit}}(\text{P116})}$$

P 2 6 8 MM Ke factor

Here, you set the motor EMF, relative to 1,000 RPM (voltage constant), of the synchronous or asynchronous machine.

If no value is available for the Ke factor, you can proceed as follows:

- Set a speed specified value that corresponds to the motor's rated speed (P262)
- Enable the drive and run it at no-load
- By changing Ke (P268), bring the I_q controller output (P068) down to approximately 0%

Parameter description for asynchronous machines

P 2 6 4 MM Kp flux controller

This parameter sets the gain (Kp) of the flux controller.
Kp = 3 ... 6.

P 2 6 5 MM Tn flux controller

This parameter sets the integral action time (Tn) of the flux controller.
Tn ≈ 1/2 * P293.

P 2 9 3 MM Tr rotor actual value

This parameter displays the rotor time constant (Tr) of the asynchronous machine.



NOTE

When there is a pulse and controller enable at the same time, the torque specified value does not become effective until 3 × Tr has expired. This ensures that torque build-up is based on an existing magnetic field.

P 2 6 6 MM flux set value

P 2 6 7 MM flux actual value

This parameter shows the flux actual and set value of the asynchronous machine.

P 2 6 9 MM mode

Bit no.	Meaning
0	0 : Follow-up of temperature is switched off 1 : Follow-up of temperature is active
1	0 : Generatoric torque limiting is switched off 1 : Generatoric torque limiting is active
2 ... 15	reserved

P 2 6 2 MM nominal speed

The nominal speed can be read on the type label / motor data sheet of the motor.

P 2 6 3 MM nominal frequency

The nominal frequency at nominal torque can be read on the type label / motor data sheet of the motor. This nominal frequency results in the thermic state of the machine - P296 MM temperature 2 (warm).

P 2 9 4 MM frequency temperature 1

P 2 9 5 MM temperature 1

P 2 9 6 MM temperature 2

P 2 9 7 MM frequency = f (temp)

The asynchronous motor's rated frequency is changed; this change is linear in dependence on the motor temperature (P153). As a result of this, there is constant torque across the motor temperature, assuming that the cross current is constantly regulated.

It is: 10.0 Hz ≤ P294 ≤ P263 ≤ 600.0 Hz
 -30°C ≤ P295 ≤ P296 ≤ 230°C

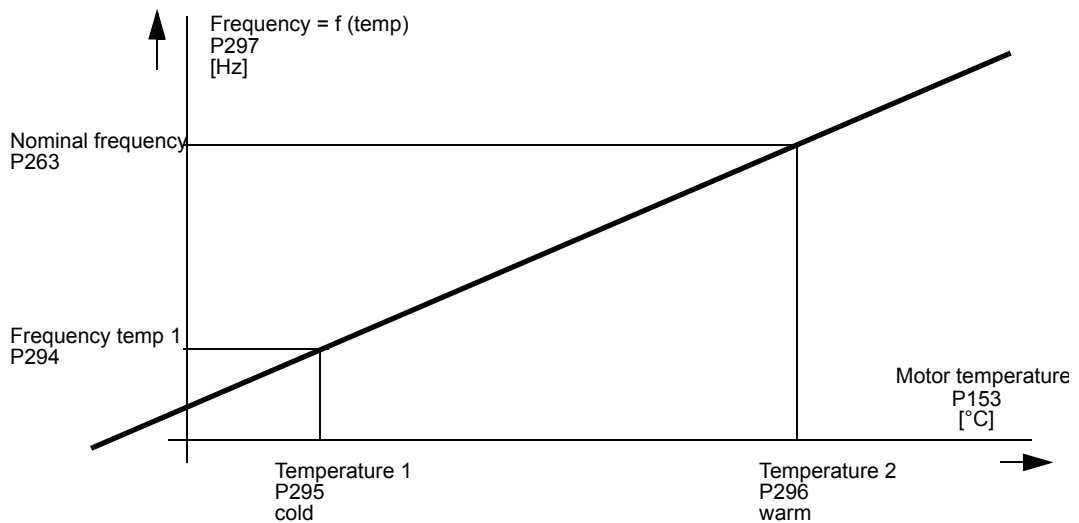

As a good approximation, you can expect for the slip while the machine – P295 MM temperature 1 – is cold, approximately 75% of the rated slip under thermic loading.

This results in the frequency that has to be set for temperature 1:

$$P294 \text{ MM frequency temp1} = \frac{P263 + \frac{P262}{60 \cdot \frac{s}{\text{min}}} \cdot P033 \cdot 0,3}{1,3}$$

Example:

P263 MM nominal frequency= 53,6 Hz
 P295 MM temperature 1 = 20 °C
 P296 MM temperature 2 = 80 °C
 P262 MM nominal speed = 1500 rpm
 P033 Mot no. of pole pairs = 2

$$P294 \text{ MM frequency temp1} = \frac{53,6 \text{ Hz} + \frac{1500 \text{ rpm}}{60 \cdot \frac{s}{\text{min}}} \cdot 2 \cdot 0,3}{1,3} = 52,8 \text{ Hz}$$

P 2 9 1 MM MGen1 Nnominal

P 2 9 2 MM MGen2 12000 rpm

This parameter sets the torque limiting at generator-operation of the asynchronous machine.

This results in identical torque in motor as well as generator terms.

It is $0 \% \leq P292 \leq P291 \leq 100 \%$

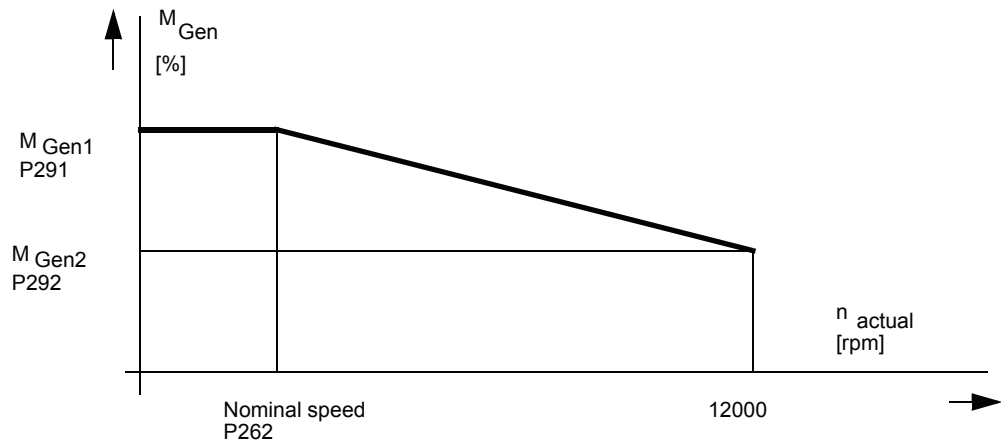

As a good approximation, you can expect around 95% for P291 M_{Gen1} N_{rate} and approximately 60% for P292 M_{Gen2} 12,000 RPM.

7.6 Overload Monitoring

Function

The overload monitor protects the power unit/motor from thermal overloading. The temperature of the power unit/motor is imitated and monitored by an I²t model.

Motor model:

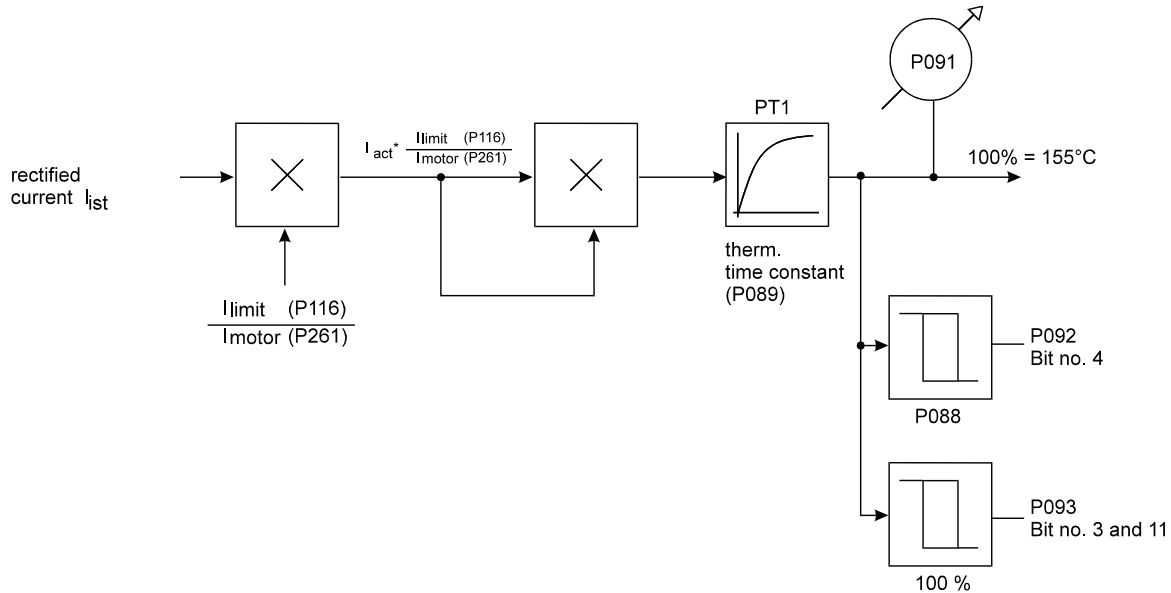

The motor temperature is measured in state NOT READY TO START (if motor temperature sensor is available).

The PT1 element is initialized on this motor temperature. Following calibration is valid 40°C ↔ 0 % and 155°C ↔ 100 % of P091. Because of that, the error „overload monitoring“ can appear in spite of low current or in the start phase.

Parameter overview

Parameter	Name	Range min. ... max.	Unit	Display only
P093	I ² t state	0000 ... FFFF		×
P089	I ² t time constant motor	0 ... 3600	s	
P088	I ² t warning limit motor	0.00 ... 100.00	%	
P091	I ² t value motor	0.00 ... 40000.00	%	×

Example

Power unit: BUS 621

$$I_{nom} = 10 A_{eff}$$

Motor: DS 56 L - 3000; (P065)

$$I_{nom} = 5.1 A_{eff}$$

$$T_t = 26 \text{ min.} = 1560 \text{ s}$$



NOTE

The motor nominal current is set in parameter MM motor nominal current (P261).

P116: Set current I_{limit} (maximum current e.g. at acceleration) e. g. $I_{limit} = 8 \text{ A}$

P088: 80 % (warning limit)

P089: 1560 s

P099: Level change from 0 % to 100 % I_{nom} of power unit

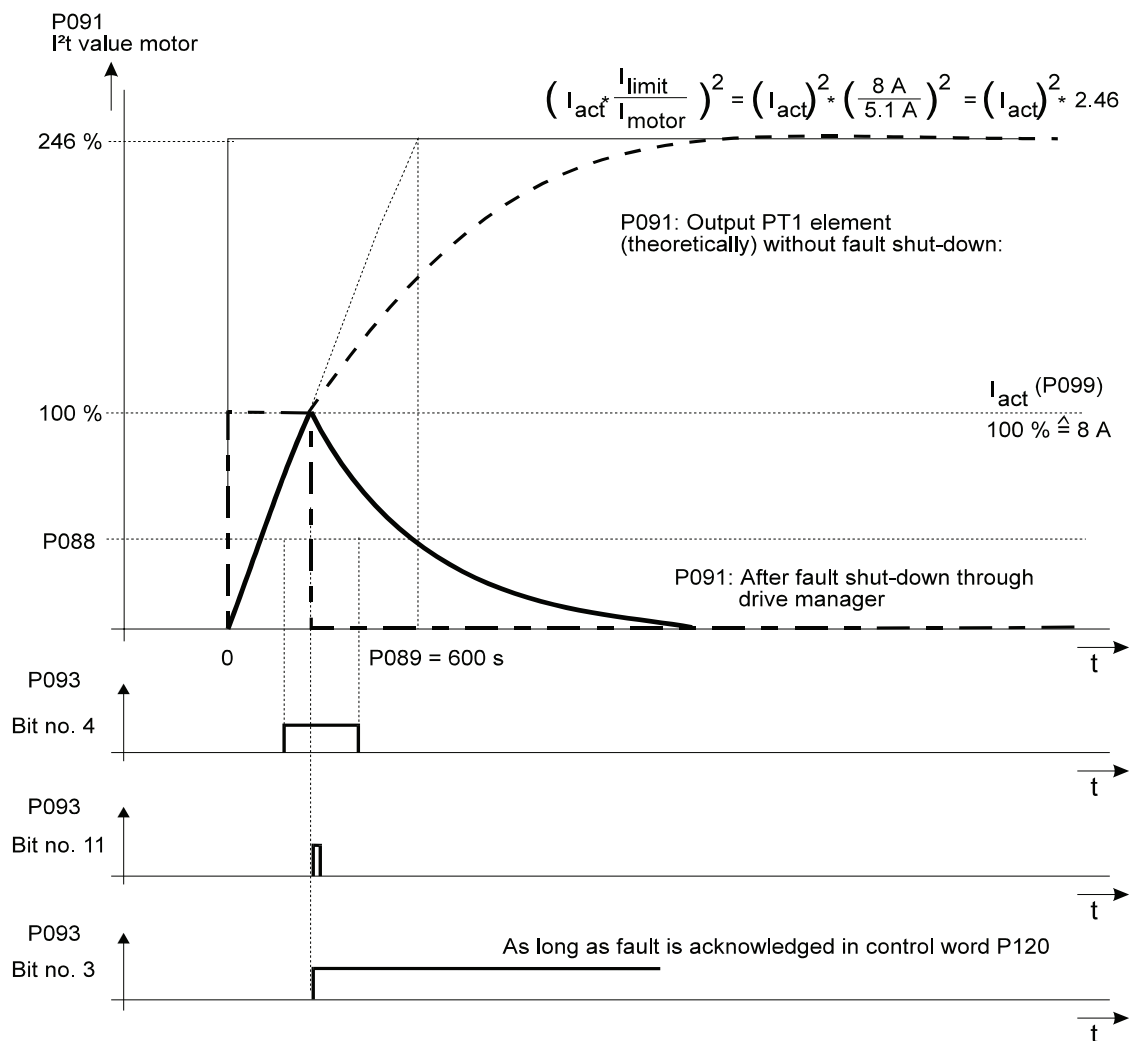

Parameter description

P093 I2t state

The state shows the function module state.

Bit no.	Meaning
0 ... 2	000: STOP 001: RUN 010: LINE 011: STAND_BY
3	1: Error in function module, error code see M error code (P124)
4	1: Warning: I ² t value motor > limit motor (P088)
5 ... 10	reserved
11	1: I ² t value motor > 100 %
12 ... 15	reserved

P089 I2t time constant motor

The thermal time constant of the motor Tt [s] (see technical data motor) must be entered in sec..

If motor time constant = 0 the overload monitoring is turned off.

P088 I2t warning limit motor

If this value is exceeded the bit „motor overload warning“ (bit no. 4, P093) is set.

Standardization

$$100 \% \leftrightarrow 155 \text{ }^{\circ}\text{C}$$

P091 I2t value motor

This parameter shows the output of the PT1 element.

Standardization

$$100 \% \leftrightarrow 155 \text{ }^{\circ}\text{C}$$

7.7 Motor Temperature Monitoring

Function

This module protects the motor from thermal overloading.

Parameter overview

Parameter	Name	Range min. ... max.	Unit	Display only
P151	MT state	0000 ... FFFF		×
P152	MT mode	0000 ... 0029		
P153	MT temperature	-40 ... 250	°C	×
P154	MT threshold 1	-40 ... 250	°C	
P155	MT threshold 2	-40 ... 250	°C	
P156	MT shutdown threshold	-40 ... 250	°C	
P157	MT hysteresis	0 ... 5	°C	

Parameter description

P 151 MT state

The module state is displayed here.

Bit no.	Meaning
0 ... 2	000: STOP Motor temperature monitoring is switched off 001: RUN Motor temperature monitoring is active
3	1: Error in function module, error code see M error code (P124)
4	1: Motor temperature has exceeded threshold 1
5	1: Motor temperature has exceeded threshold 2
6	1: Motor temperature has exceeded shutdown threshold
7	1: shutdown switch / PTC thermistor responses
8 ... 15	reserved

P 152 MT mode

This parameter sets the motor temperature recording type..

Bit no.	Meaning
0 ... 2	Sensor type 000: No sensor, temperature monitoring is switched off 001: Temperature sensor KTY 84 010: reserved 011: reserved 100: reserved 101: reserved 110: reserved 111: reserved
3	0: If the shutdown threshold P156 is exceeded, the error bit in MT state is enabled and a shutdown follows. 1: If the shutdown threshold P156 is exceeded, the warning bit no. 6 in MT state is enabled and no shutdown follows.
4 ... 5	Input mode 00: The temperature is monitored with connector X26, pin no. 9 and 10 01: The temperature is monitored with connector X24, pin no. 14 and 15 (interface encoder 1) 10: The temperature is monitored with connector X25, pin no. 14 and 15 (interface encoder 2) 11: reserved
6 ... 15	reserved

P 153 MT temperature

This parameter indicates the measured motor temperature if a temperature sensor is used.

P 154 MT threshold 1

P 155 MT threshold 2

P 156 MT shutdown threshold

The temperature ascertained by the temperature sensor is compared to these parameters and the relevant bits are set in the status word.

P 157 MT hysteresis

On exceeding a threshold the relevant set and it is reset only after falling below the threshold minus hysteresis.

Example:

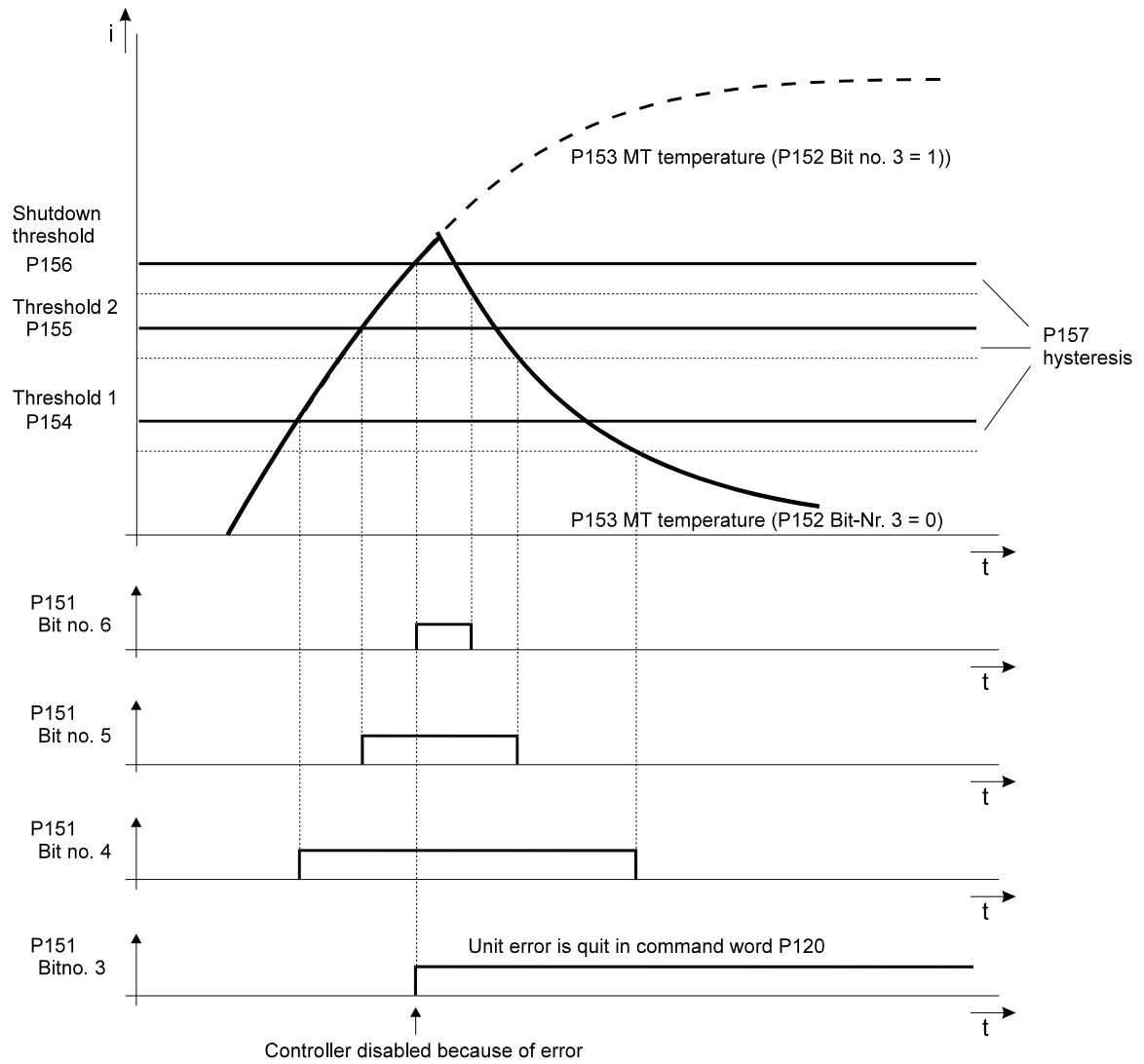

7.8 Field Angle Calculation

Function

In this function module, the electrical field angle is calculated from the number of pole pairs of the motor and the mechanical rotor angle. Apart from this, the module contains the algorithms for determining the locating position and the rotor position, which play a significant part in the operation of synchronous machines.

Parameter overview

Parameter	Name	Range min. ... max.	Unit	Display only
P036	Mot state	0000 ... FFFF		×
P031	Mot mode	0 ... 4		
P033	Mot no. of pole pairs	1 ... 120		
P034	Mot rotating field	0 ... 1		
P037	Mot delta l	1 ... 50		
P039	Mot delta Rho	1 ... 50		
P035	Mot locating angle	0.0 ... 360.0	degrees	
P030	Mot phi mechanical	0.0 ... 360.0	degrees	×
P032	Mot rho electrical	0.0 ... 360.0	degrees	×

Parameter description

P036 Mot state

This parameter shows the status of the function module.

Bit No.	Meaning
0 ... 2	0: STOP 1: RUN Normal operation 3: STAND_BY Optimization algorithms are running
3	1: Error in module; for error code, refer to P012
4	1: Locating point found (method 0, 1) 0: Locating point still unknown
5	1: Rotor position found (method 2, 3, 4) 0: Rotor position still unknown
6 ... 15	Reserve

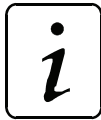

NOTE

Before the controller can be enabled, following parameters must be set:

- Motor model
- Limit current
- Encoder
- Current controller
- Operation mode
- Controller enabling

P031 Mot mode

Selection of the optimization method for Location Point Reference Setting mode.

With all the optimization methods, the controller sets its own current specified value using parameter P067 M specified value. This means that the system must not write to this parameter during optimization (e.g. via the communications interfaces, digital inputs, etc.).

Value	Meaning
0	Set reference to encoder's installation position (location point) (method 0)
1	Set reference to encoder's installation position (location point) (method 1)
2	Set reference to rotor position of synchronous machine (method 2)
3	Start up a clockwise-rotating synchronous machine (method 3)
4	Start up a counterclockwise-rotating synchronous machine (method 4)

To 0: Mode Set reference to encoder's installation position (location point) is intended for operation of a synchronous machine with an absolute value encoder or a resolver. You **must** dismount the motor when carrying out this optimization. The current specified value increases in a linear way from 0% to 100%; after this, the system determines the current values and sets bit number 4, Locating position found, in Mot Status.

To 1: Mode Set reference to encoder's installation position (location point) is intended for operation of a synchronous machine with an absolute value encoder or a resolver. You **must not necessarily** dismount the motor when carrying out this optimization. However, the motor shaft must be able to move load-free in both directions by about one or two degrees. After completing optimization, the system sets bit number 4, Locating position found, in Mot Status.

To 2: Mode Set reference to rotor position is intended for operation of a synchronous machine with an incremental encoder. This means that before commissioning a drive of this type, you must carry out this optimization function first. You **must not necessarily** dismount the motor when carrying out this optimization. However, the motor shaft must be able to move load-free in both directions by about one or two degrees. After completing optimization, the system sets bit number 5, Rotor found, in Mot Status.

To 3 and 4: These modes are intended for operation of a synchronous machine with an incremental encoder. The system keeps moving the synchronous machine with a clockwise- or counterclockwise-rotating electrical angle until the incremental encoder's zero pulse has been measured. After this, the system sets bit number 5, Rotor found, in Mot Status.

P 0 3 3 Mot no. of pole pairs

Pole pairs of the used motor.

P 0 3 4 Mot rotating field

This parameter matches the control to the rotating field of the motor.

Value	Meaning
0	motor with anti-clockwise rotating field (phase V and W changed)
1	motor with clockwise rotating field



NOTE

After making changes to Mot rotating field, you **must** save data set 0 (the boot data set) and reboot the controller!

P 0 3 7 Mot delta I

Using this parameter, you can specify the setting for the current rise per unit of time $\frac{di}{dt}$. This is only necessary for Mot Modes 1 and 2. The value 1 means that the current rise per second is 3.05% of the limit current (P166 LT I lim).

P 0 3 9 Mot delta rho

This parameter sets the angular velocity of the electrical angle $\frac{dRho}{dt}$. This is only necessary for Mot Modes 1 and 2. The value 1 means that the angular change per second is 2.75° electrical.

P 0 3 5 Mot locating angle

This parameter shows the locating angle that was determined in mode Set reference to locating point. This offset value is included in calculation of the electrical angle such that an angle of 90° electrical results in the location position.

P 0 3 0 Mot phi mechanical

This parameter displays the mechanical rotor angle.

P 0 3 2 Mot rho electrical

This parameter displays the calculated electrical field angle.

7.9 Encoder Manager

Function:

The module manages the classification of encoder 1 (X24) and 2 (X25) to motor control, speed controller and synchronisation control as well as incremental encoder emulation.

Parameter overview

Parameter	Name	Range min. ... max.	Unit	Display only
P225	EM state	0000 ... FFFF		×
P228	EM encoder types	000000FF		×
P226	EM mode	0000 ... 003F		
P227	EM no. of graduation marks	128 ... 32767	lnk	
P229	EM offset zero impulse	0000 ... FFFF	Inc	
P019	EM maximum speed	500 ... 120000	rpm	
P224	EM kp	0 ... 32767		

Parameter description

P225 EM state

Display of the internal module state

Bit no.	Meaning
0 ... 2	000: STOP 001: RUN
3	1: Error in function module, error code see M error code (P124)
4 ... 6	reserved
7	Absolute position of the encoder for motor control is not known
8, 9	reserved
10	Copy of N=0 message from state encoder 1 (P025), if EM mode, bit no. 0 = 0 or copy of N=0 message from state encoder 2 (P240) , if EM mode, bit no. 0 = 1
11 ... 15	reserved

P 2 2 8 EM encoder types

Shows the really quipped encoder modules (see type code).

Bit no.	Meaning
0 ... 3	Encoder type at connection 2 (X24) 0: no encoder A: resolver B: sinus incremental encoder 5 V C: absolute value encoder with asynchronous serial interface 8 V D: absolute value encoder with synchronous serial interface 5 V E: rectangle incremental encoder 5 V
4 ... 7	Encoder type at connection 2 (X25) 0: no encoder A: resolver B: sinus incremental encoder 5 V C: absolute value encoder with asynchronous serial interface 8 V D: absolute value encoder with synchronous serial interface 5 V E: rectangle incremental encoder 5 V
8 ... 15	reserved

P 2 2 6 EM mode

Bit no.	Meaning
0	0: Rotor angle and speed is measured by encoder 1 1: Rotor angle and speed is measured by encoder 2 This bit can only be changed if the position controller's state is STOP.
1	0: Incremental encoder emulation is connected with position actual value G1/G2. 1: Incremental encoder emulation is connected with position actual value.
2	0: Incremental encoder emulation is switched off 1: Incremental encoder emulation is active
3	0: Incremental encoder emulation is connected with encoder 1 1: Incremental encoder emulation is connected with encoder 2
4	Change polarity of incremental encoder emulation: 0: With a clockwise-rotating encoder (depending on bit number 3) the system outputs a clockwise-rotating signal pattern on connector X 27. 1: With a clockwise-rotating encoder (depending on bit number 3) the system outputs a counterclockwise-rotating signal pattern on connector X 27.
5	0: The no. of graduation marks is multiplied by 1 1: The no. of graduation marks is multiplied by 8
6	0: Smoothing of incremental encoder emulation is inactive 1: Smoothing of incremental encoder emulation is active
7 ... 15	reserved

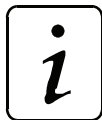

NOTE

After setting the mode parameter the data set 0 (boot data set) should be saved and the controller should be booted new.

The incremental encoder emulation can be used in combination with following encoders (see type code, too):

Incremental encoder emulation	Encoder 1 X24	Encoder 2 X25
not active bit no. 2 = 0	SCM 70, SCS 70 rectangle inc. 5 V sine inc. 5 V resolver	SCM 70, SCS 70 rectangle inc. 5 V sine inc. 5 V resolver
active bit no. 2 = 1	resolver 2 pole pairs or no encoder	SCM 70, SCS 70 rectangle inc. 5 V sine inc. 5 V resolver

The internal delay time between getting the encoder signals (encoder 1 (X24) and encoder 2 (X25)) and the output through the incremental encoder emulation X27 is maximal 90 µs.

P 2 2 7 EM no. of graduation marks

This parameter sets the no. of graduation marks of the incremental encoder emulation. The no. of graduation marks refers to 1 revolution of encoder chosen with P226 EM mode bit no. 3. Bit no. 5 of EM mode selects the multiplicands for the number of graduation marks. The limit frequency is 2,4 MHz.

P 2 2 9 EM offset zero impulse

This parameter sets the angle offset between the zero angle of encoder chosen with P226 and zero impulse of incremental encoder emulation.

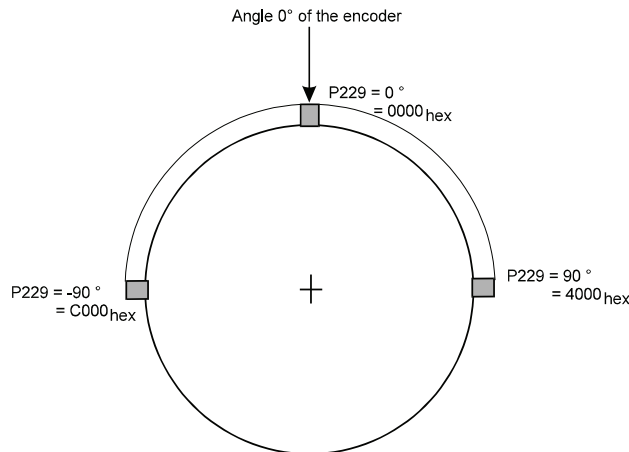

P 0 1 9 EM maximum speed

This parameter sets the maximum speed. This speed corresponds to 100 % in all other speed specifications e.g. speed set values, speed actual values and monitoring thresholds of both encoders.
e.g.: 100 % n_{set} ↔ 2800 rpm, if maximum speed is set to 2800 rpm.

P 2 2 4 EM kp

This parameter sets the P gain of the incremental encoder emulation.

7.10 Evaluation Encoder 1 and Encoder 2

Parameter overview encoder 1

Parameter	Name	Range min. ... max.	Unit	Display only
P025	G1 state	0000 ... FFFF		×
P040	G1 mode	0000 ... 1133		
P024	G1 no. of graduation marks	1 ... 32767	Inc	
P062	G1 N smoothing actual value	0.0 ... 50.0	ms	
P023	G1 N actual value	-199.99 ... +199.99	%	×
P043	G1 rev actual value	00000000 ... FFFFFFFF		×
P022	G1 phi actual value	00000000 ... FFFFFFFF		×
P041	G1 delta Phi 16	8001 ... 7FFF		×
P042	G1 delta Phi 32	80000001 ... 7FFFFFFF		×
P044	G1 sine measured value	-1.0000 ... +1.000		×
P045	G1 cosine measured value	-1.0000 ... +1.000		×
P026	G1 sine offset	-0.2500 ... +0.2500		
P027	G1 cosine offset	-0.2500 ... +0.2500		
P028	G1 sine gain	0.500 ... 2.000		
P029	G1 cosine gain	0.500 ... 2.000		
P020	G1 sine	-1.0000 ... +1.000		
P021	G1 cosine	-1.0000 ... +1.000		
P107	G1 N=0 threshold	0.01 ... 25.00	%	
P108	G1 N>Nx ON threshold	0.00 ... 150.00	%	
P109	G1 N>Nx OFF threshold	0.00 ... 150.00	%	
P046	G1 over speed	0.00 ... 199.99	%	

Parameter overview encoder 2

Parameter	Name	Range min. ... max.	Unit	Display only
P240	G2 state	0000 ... FFFF		×
P241	G2 mode	0000 ... 1133		
P242	G2 no. of graduation marks	1 ... 32767	Inc	
P238	G2 N smoothing actual value	0.0 ... 50.0	ms	
P243	G2 N actual value	-199.99 ... +199.99	%	×
P249	G2 rev actual value	00000000 ... FFFFFFFF		×
P244	G2 phi actual value	00000000 ... FFFFFFFF		×
P247	G2 delta Phi 16	8001 ... 7FFF		×
P248	G2 delta Phi 32	80000001 ... 7FFFFFFF		×
P230	G2 sine measured value	-1.0000 ... +1.000		×
P231	G2 cosine measured value	-1.0000 ... +1.000		×
P232	G2 sine offset	-0.2500 ... +0.2500		
P233	G2 cosine offset	-0.2500 ... +0.2500		
P234	G2 sine gain	0.500 ... 2.000		
P235	G2 cosine gain	0.500 ... 2.000		
P236	G2 sine	-1.0000 ... +1.000		
P237	G2 cosine	-1.0000 ... +1.000		
P104	G2 N=0 threshold	0.01 ... 25.00	%	
P105	G2 N>Nx ON threshold	0.00 ... 150.00	%	
P106	G2 N>Nx OFF threshold	0.00 ... 150.00	%	
P239	G2 over speed	0.00 ... 199.99	%	

Parameter description

P025 G1 state

P240 G2 state.

Bit no.	Meaning
0 ... 2	000: STOP 001: RUN 101: INIT
3	1: Error in function module, error code see M error code (P124)
4	logic level or zero trace
5	toggle bit for zero trace: changes at every zero impulse
6	1: $ N \text{ actual value} > \text{overspeed threshold (P046 or P239)}$ If this encoder controls the motor, the exceeding leads to a error message and disables the controller.
7	1: Absolute position of encoder is not known.
8 ... 9	Reserve
10	0: $ N \text{ actual value} \neq 0$ 1: $ N \text{ actual value} = 0$ (below $N = 0$ threshold)
11	0 \rightarrow 1: $ N \text{ actual value} > N_x \text{ ON (P108, P105)}$ 1 \rightarrow 0: $ N \text{ actual value} > N_x \text{ OFF (P109, P106)}$
12	reserved
13	1: limit value reached; $ N \text{ actual value} > \text{maximum speed P019}$
14 ... 15	reserved



NOTE

The bit no. 4 and 5 are specially destined for the adjustment of encoders. Incremental encoders with high no. of graduation marks can be fast adjusted, if this bits are connected with the free programmable LEDs.

P040 G1 mode

P241 G2 mode

This parameter sets the encoder evaluation.



NOTE

After setting the mode parameter the data set 0 (boot data set) should be saved and the controller should be new booted.

Bit no.	Meaning
0	Encoder polarity: 0: No sign reversal, turning clockwise encoder supplies positive speed actual value. 1: Sign reversal, turning clockwise encoder supplies negative speed actual value.
1	Polarity position counting: 0: Positive speed actual value effects positive position change 1: Positive speed actual value effects negative position change .
2	0: The multiplier for no. of graduation marks is 1. 1: The multiplier for no. of graduation marks is 8.
3	reserved
4 ... 7	Encoder type: 0000: no encoder 0001: resolver 0010: rectangle encoder 0011: sine encoder
8 ... 11	Communication protocol: 0000: no protocol 0001: Protocol for SinCos encoder from Fa. Stegmann (SCM70 or SCS70)
12	1: Standardization algorithm for offset and gain is active.
13 ... 15	reserved

Permitted setting for encoder mode and no. of graduation marks:

Letter for encoder in type code	Mode	No. of graduation marks	Comment
0	0000 _{hex}	×	no encoder evaluation
A	0010 _{hex}	16384	resolver
B	0030 _{hex}	number of sine periods	incremental encoder sine with 5 V supply
C	0130 _{hex}	512	sine absolute value encoder with asynchronous serial interface and 8 V supply SCS 70 and SCM 70 from Fa. Stegmann
D	-	-	sine absolute value encoder with synchronous serial interface and 5 V supply
E	0020 _{hex}	no. of graduation marks	rectangle incremental encoder with 5 V supply

P024 G1 no. of graduation marks

P242 G2 no. of graduation marks

No. of graduation marks or number of periods of connected encoder.



NOTE

The no. of graduation marks of 2 pole resolvers must be set to 16384.

The multiplier for the no. of graduation marks is set by bit no. 5 in G1/G2 mode. The no. of graduation marks and the maximum really speed must not be greater than 2,4 MHz.

$$f = \frac{\text{No. of graduation marks} * \text{Multiplier} * \text{Speed}}{60} < 2,4\text{MHz}$$

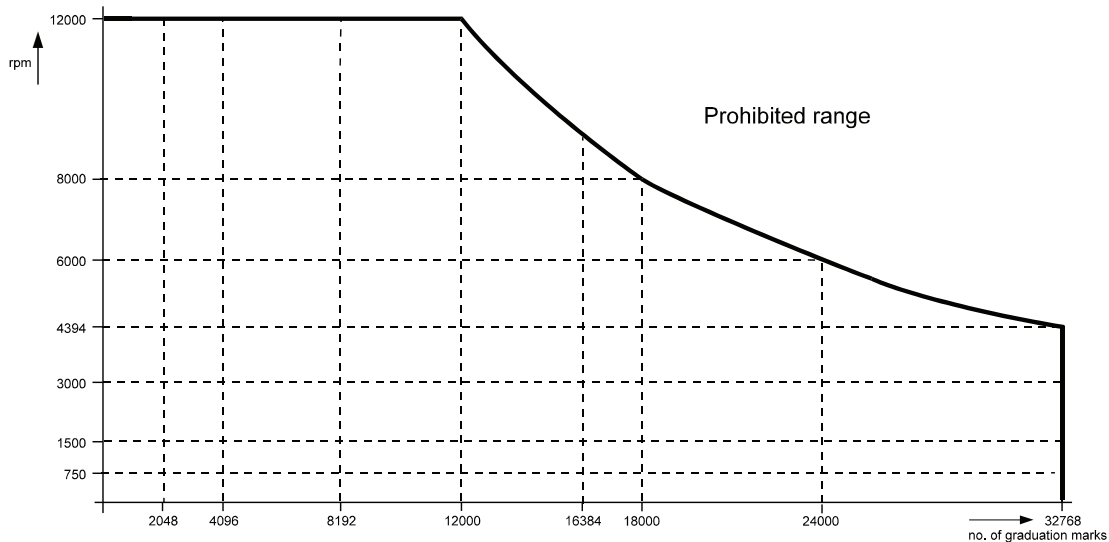

P062 G1 N smoothing actual value

P238 G2 N smoothing actual value

This parameter sets the time constant to smooth the speed actual value.

P023 G1 N actual value

P243 G2 N actual value

N actual value at encoder 1 or encoder 2, referring to maximum speed (P019).
100 % correspond with set maximum speed in P019.

P043 G1 Rev actual value

P249 G2 Rev actual value

Part of the position actual value: number of whole revolutions.

P022 G1 phi actual value

P244 G2 phi actual value

Part of the position actual value: the angle within one rotation, left-justified with encoder-dependent resolution.

The entire position actual value is 64-bits-long and consists of the following:

63		32		31		0
31	Rev actual value	0	31	Phi actual value	0	0

The system zeroes the entire position actual value after you switch on the power to the electronics. If an absolute value encoder is connected, the system reads it out and enters the information in accordance with the format shown above. The position actual value can be overwritten at any time.

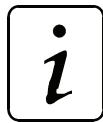

NOTE

Every error that occurs in the encoder module (error code 08xx/0Axx) results in the absolute position of the encoder evaluation being lost. This means that if you use this encoder to acquire the rotor position of a synchronous machine, this position information is also lost and it is no longer possible to safely control the motor. Every time an encoder error occurs, you must therefore reinitialize the controller electronics (by turning the power off and on again).

P041 G1 delta phi 16

P247 G2 delta phi 16

P042 G1 delta phi 32

P248 G2 delta phi 32

When writing this parameter the system adds once the specified angular differences with 16- or 32-bit resolution onto the position actual value (relative angular change).

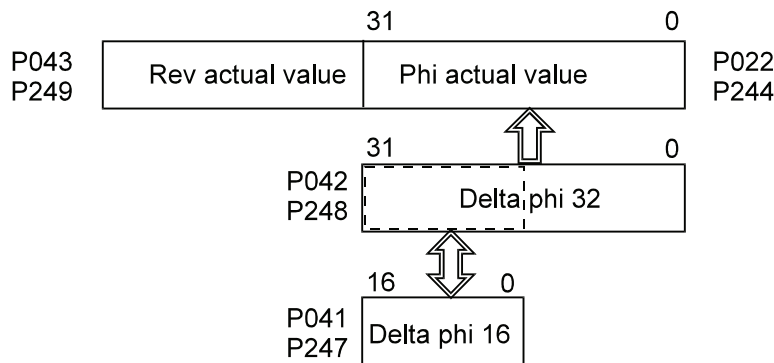

Parameter

Positive and negative carries to whole revolutions (Rev actual value) are taken into account.

$$8001_{\text{hex}} = -180^\circ$$

$$0000_{\text{hex}} = 0^\circ$$

$$7FFF_{\text{hex}} = +180^\circ$$

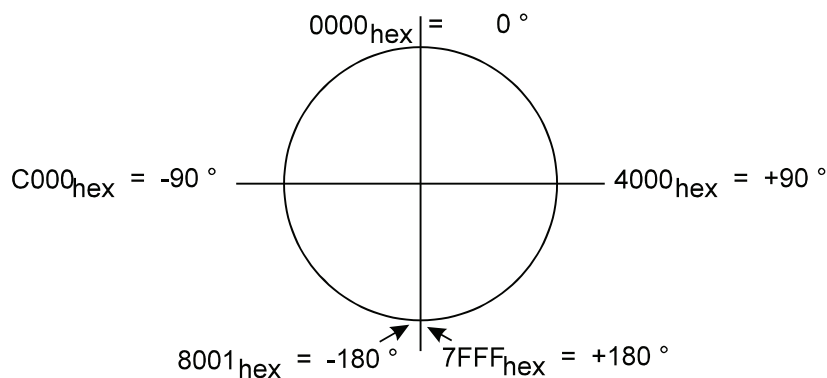

P044 G1 sine measured value

P045 G1 cosine measured value

P230 G2 sine measured value

P231 G2 cosine measured value

Measured values of connected encoder. M

P026 G1 sine offset

P027 G1 cosine offset

P028 G1 sine gain

P029 G1 cosine gain

P232 G2 sine offset

P233 G2 cosine offset

P234 G2 sine gain

P235 G2 cosine gain

This parameter can compensate offset and gain faults of the analog actual value measurement.

P020 G1 sine

P021 G1 cosine

P236 G2 sine

P237 G2 cosine

Corrected measured values.

P 107 G1 N=0 threshold

P 104 G2 N=0 threshold

Bit no. 10 in function module state is enabled, if the absolute value of N actual value is below the threshold N=0 (P107 encoder 1 or P104 encoder 2).

The input value is related to P019 maximum speed..

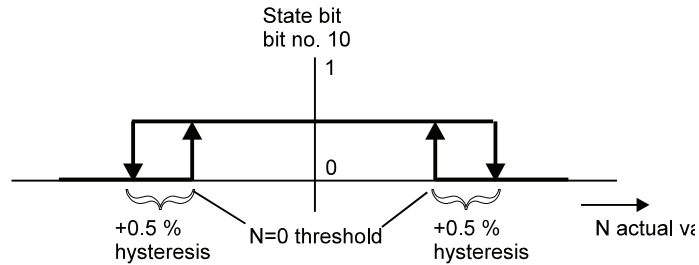

P 108 G1 N>Nx ON threshold

P 109 G1 N>Nx OFF threshold

P 105 G2 N>Nx ON threshold

P 106 G2 N>Nx OFF threshold

Freely programmable speed thresholds to set the corresponding bits in G1 or G2 state. If $|N \text{ actual value}|$ (P051) is greater than N>Nx ON threshold, then bit no. 11 is enabled and disabled if $|N \text{ actual value}|$ falls below N>Nx OFF threshold.

The input value is related to P019 maximum speed.

P 046 G1 overspeed

P 239 G2 overspeed

Threshold value for overspeed monitoring.

The input value is related to P019 maximum speed..

If the set value is exceeded the bit no. 6 is enabled in G1 or G2 state. The bit is disabled if the speed drops below the threshold (no hysteresis).

7.11 Current Controller

Parameter overview

Parameter	Name	Range min. ... max.	Unit	Display only
P079	I state	0000 ... FFFF		×
P080	I P gain	0.1 ... 15.9		
P081	I integral action time	0.0 ... 1000.0	ms	
P082	I U_q/U_d - limit	0.00 ... 100.00	%	
P067	I M set value	-100.00 ... 100.00	%	
P048	I M additional set value	-100.00 ... 100.00	%	
P071	I I_q set value	-100.00 ... 100.00	%	
P072	I I_q actual value	-199.99 ... 199.99	%	×
P068	I I_q controller output	-100.00 ... 100.00	%	×
P069	I EMC set value	-100.00 ... 100.00	%	×
P075	I U_q set value	-100.00 ... 100.00	%	×
P077	I I_d set value	-100.00 ... 100.00	%	
P078	I I_d actual value	-199.99 ... 199.99	%	×
P076	I U_d set value	-100.00 ... 100.00	%	×
P070	I phase voltage U	-100.00 ... 100.00	%	×
P086	I phase voltage V	-100.00 ... 100.00	%	×
P073	I phase voltage U	-100.00 ... 100.00	%	×
P074	I phase current V	-100.00 ... 100.00	%	×
P083	I current offset U	-25.00 ... 25.00	%	×
P084	I current offset V	-25.00 ... 25.00	%	×
P099	I current actual value	0.00 ... 100.00	%	×

Parameter description

P079 | state

This parameter indicates the status of the internal function module.

Bit No.	Meaning
0 ... 2	000: STOP (controller inhibited) 001: RUN (controller enabled) 011: STAND_BY (direct-axis current controller inhibited, field has been set-up) 101: INIT (direct-axis current controller enabled, field is being set-up)
3	Error in module
4	0: Current control on synchronous machine 1: Current control on asynchronous machine
5	0: No field available 1: Field is available In the case of the asynchronous machine, after $3 \times P293$ (rotor time constant T_v) has expired, the direct-axis current, P078, must be at least 80% of the direct-axis current P077. After this, the system does not continuously monitor the in-phase regulator.
6 ... 15	Reserve

P080 | P gain

This parameter sets P gain (k_p) for the direct axis current controller and the wattless current controller.

P081 | integral action time

This parameter sets the integral action time (T_N) of the direct-axis current controller and the wattless current controller.

P082 | U_q/U_d limit

This parameter sets the limit of the direct-axis current controller and the wattless current controller..

$$\text{Standardization:} \quad 100 \% \leftrightarrow \frac{U_{ZKnom}(P087)}{\sqrt{2}}$$

P067 | M set value

Set value input for current control mode (P122 = -2)

$$\text{Standardization:} \quad 100 \% \leftrightarrow \text{PU I limit (P116)}$$

P048 | **M additional set value**

Additional set value for all modes. .

Standardization: 100 % ↔ PU I limit (P116)

The effective torque set value is the sum of M set value and M additional set value.



NOTE

When there is a pulse and controller enable at the same time, the torque specified value does not become effective until $3 \times T_r$ has expired. This ensures that torque build-up is based on an existing magnetic field.

P071 | **I_d set value**

P072 | **I_d actual value**

Standardization: 100 % ↔ PU I limit (P116)

P068 | **I_q controller output**

Manipulated variable of wattless current controller.

Standardization: 100 % ↔ $\frac{U_{ZKnom}(P087)}{\sqrt{2}}$

P069 | **EMC set value**

Voltage set value from motor model, corresponds with machine's EMC. .

Standardization: 100 % ↔ $\frac{U_{ZKnom}(P087)}{\sqrt{2}}$

P075 | U_q set value

Sum of P068 I_q controller output and P069 EMC set value..

Standardization: 100 % $\leftrightarrow \frac{U_{ZKnom}(P087)}{\sqrt{2}}$

P077 | I_d set value

P078 | I_d actual value

The direct-axis current set value / actual value is displayed here.

Standardization: 100 % \leftrightarrow PU I limit (P116)

P076 | U_d set value

Manipulated variable of direct-axis controller..

Standardization: 100 % $\leftrightarrow \frac{U_{ZKnom}(P087)}{\sqrt{2}}$

P070 | phase voltage U

P086 | phase voltage V

This parameter displays the voltage set value of phase U or V. .

Standardization: 100 % $\leftrightarrow \frac{U_{ZKnom}(P087)}{\sqrt{2}}$

P073 | phase current U

P074 | phase current V

Standardization: 100 % \leftrightarrow PU I limit (P116)

P083 | current offset U

P084 | current offset V

To compensate the offset of the current transformer, the current transformer is set to 0 at every pulse enabling. This parameter shows the offset value.

Standardization: 100 % $\leftrightarrow 2^{11}$

P099 | current actual value

Standardization: 100 % \leftrightarrow PU I limit (P116)

7.12 Speed Controller

Parameter overview

Parameter	Name	Range min. ... max.	Unit	Display only
P059	N state	0000 ... FFFF		×
P057	N P gain	0.1 ... 1000.0		
P058	N integral action time	1.0 ... 2000.0	ms	
P049	N J compensation	0 ... 30000		
P050	N set value	-100.00 ... 100.00	%	
P047	N additional set value	-100.00 ... 100.00	%	
P051	N actual value	-199.99 ... 199.99	%	×
P052	N controller output	-100.00 ... 100.00	%	
P038	N M limiter mode	0 ... 1		
P053	N M limiter bipolar	0.00 ... 100.00	%	
P054	N M limiter Mot/TD1	0.00 ... 100.00	%	
P055	N M limiter Gen/TD2	0.00 ... 100.00	%	
P060	N deviation	-199.99 ... 199.99	%	×
P061	N limiter deviation	0.00 ... 199.99	%	
P056	N block time	0.0 ... 360.0	s	

Parameter description

P059 N state

This parameter shows the speed controller's state.

Bit no.	Meaning
0 ... 2	000: STOP, N controller disabled 001: RUN, N controller enabled 011: STAND_BY, N disabled, block monitoring enabled
3	1: Error in module. error code see P124
4	1: Drive is blocked (block monitoring time P056 active)
5 ... 9	reserved
10	0: motor-operated mode 1: generator-operated mode
11	0: torque direction 1 active 1: torque direction 2 active
12	1: set value reached (Deviation P060 < limiter deviation (P061))
13	1: limiter set value reached (current limiter)
14 ... 15	reserved

P057 N P gain

P gain (K_p) of speed controller.

P058 N integral action time

Integral action time (T_N) of speed controller.

P049 N J compensation

Moment of inertia compensation.

P047 N additional set value

P050 N set value

Set value inputs for speed controller. The effective set value is the limited sum from P047 and P050.

Standardization: 100 % ↔ GM maximum speed (P019)

P051 N actual value

Speed actual value of encoder 1 or encoder 2 (depends on P226 EM mode bit no. 1).

Standardization: 100 % ↔ EM maximum speed (P019)

P052 N controller output

This parameter shows the set value of speed controller..

Standardization: 100 % ↔ PU I limiter (P116)

P038 N M limiter mode

This parameter switches between torque limiter motor-operated/generator-operated and torque direction TD1/TD2..

Value	Meaning
0	torque limiter Mot/Gen
1	torque limiter TD1/TD2

Torque limiter Mot/Gen

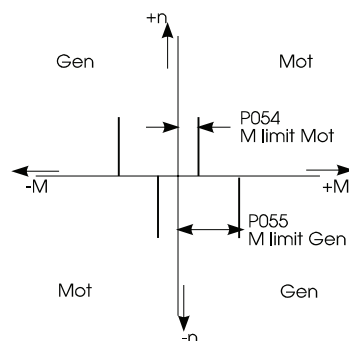

Torque limiter TD1/TD2

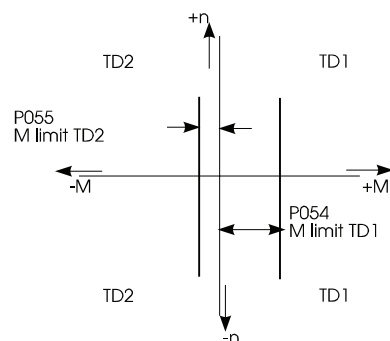

P053 N M limiter bipolar

P054 N M limiter Mot/TD1

P055 N M limiter Gen/TD2

The control value is symmetrically limited with the bipolar limiter. From the bipolar, Mot/TD2 and Gen/TD2 limiter, the respective smaller value is valid. If the I²t power unit monitoring operates, the torque limiter are internally restricted to 100 %. During the limitation bit no. 15 in N state is set.

Standardization: 100 % ↔ PU I limit (P116)

P060 N deviation

This parameter displays the actual speed controller deviation. .

Standardization: 100 % ↔ EM maximum speed (P019)

P061 N limiter deviation

If the value falls below the maximum deviation set by this parameter, the function module transmits the message set value reached (bit no. 12 in N state P059 is set). .

Standardization: 100 % ↔ EM maximum speed (P019)

P056 N block time

This parameter sets the time of the block monitoring.

The block monitoring is active, if the speed controller is on the current limit (N state, bit no. 13 = 1) and simultaneously the N = 0 message (EM state, bit no. 10 = 1) is active. During this state is active, the bit no. 4 in N state is set.

After the block monitoring time is over, the controller is disabled with error message 0702_{hex}.

7.13 Torque Monitoring

Function

This function module compares the current actual value with different limits.

Parameter overview

Parameter	Name	Range min. ... max.	Unit	Display only
P098	TM state	0000 ... FFFF		×
P096	TM M > Mx1	0.00 ... 100.00	%	
P097	TM time 1	0.000 ... 60.000	s	
P094	TM M > Mx2	0.00 ... 100.00	%	
P095	TM time 2	0.000 ... 60.000	s	
P066	TM M loading	0.00 ... 100.00	%	×
P092	TM Mact / Mn	0.00 ... 100.0	%	

Parameter description

P098 TM state

This parameter shows the function module's state.

Bit no.	Meaning
0 ... 2	001: RUN, monitoring active
3	reserved
4	M loading (P066) > threshold 1 (P096)
5	time 1 is expired
6	M loading (P066) > threshold 2 (P096)
7	time 2 is expired
8 ... 15	reserved

P096 TM M > M1

P097 TM time 1

P094 TM M > M2

P095 TM time 2

This parameters define the function

The hysteresis is each time -3 % of set threshold.

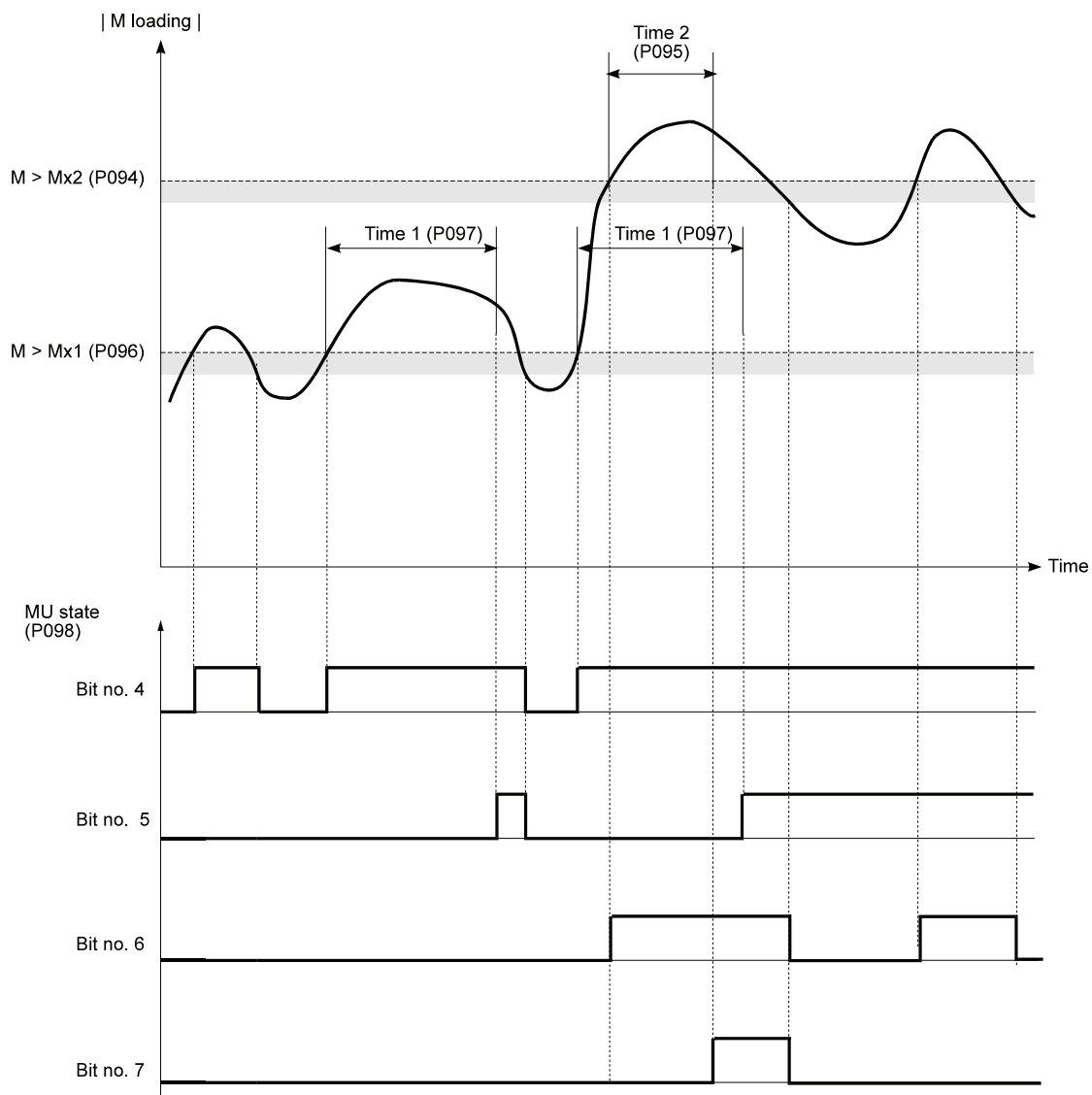

P066 TM M loading

P092 TM Mact / Mn

7.14 Position Controller

Function

The position controller module is a P-Controller for position control of the unit. The module contains multi-turn evaluation of the motor position encoder, the set value interpolator, speed precontrol as well as control variable limiting and the dynamic and static deviation.



NOTE

The efficiency of the position control is directly dependent upon the efficiency of the speed control.

Parameter overview

Parameter	Name	Range min. ... max.	Unit	Display only
P200	P state	0000 ... FFFF		×
P201	P mode	0000 ... 0007		
P202	P Kv factor	0 ... 32000	1/s	
P207	P N precontrol	0.00 ... 125.00	%	
P213	P N precontrol smoothing	0.0 ... 50.0	ms	
P220	P N precontrol output	-100.00 ... 100.00	%	
P211	P controller output	-100.00 ... 100.00	%	×
P208	P set value	00000000 ... FFFFFFFF	Inc	
P209	P actual value	00000000 ... FFFFFFFF	Inc	
P210	P deviation	80000001 ... 7FFFFFFF	Inc	×
P205	P rev set value	00000000 ... FFFFFFFF		
P206	P phi set value	00000000 ... FFFFFFFF		
P218	P rev actual value	00000000 ... FFFFFFFF		
P219	P phi actual value	00000000 ... FFFFFFFF		
P204	P N limit bipolar	0.00 ... 100.00	%	
P212	P deviation limit static	00000000 ... 7FFFFFFF	Inc	
P203	P deviation limit dynamic	00000000 ... 7FFFFFFF	Inc	
P214	P deviation time	0.000 ... 65.000	s	
P215	P active	0.01 ... 25.00	%	
P216	P time	0.000 ... 65.000	s	
P217	P threshold	0.01 ... 25.00	%	

Parameter description

P 200 P state

This parameter shows the actual position controller's mode.

Bit no.	Meaning
0 ... 2	000 : STOP, Position controller disabled 001 : RUN, Position controller enabled
3	1 : Error in position controller, error code see P124
4	1 : Dynamic deviation limiter exceeded
5	1 : Static deviation limiter exceeded
6	1 : Timeout dynamic deviation limiter
7	1 : Timeout static deviation limiter
8	1 : Actual value monitoring expects positive change
9	1 : Actual value monitoring expects negative change
10	1 : Missing actual value
11	1 : Wrong polarity of actual value change
12	1 : Set value reached (bit no. 4 and 5 are not set)
13	1 : Position controller on limit
14 ... 15	reserved

P 201 P mode

This parameter sets the position controller's operational mode.

Bit no.	Meaning
0	1 : Enabling error dynamic deviation
1	1 : Enabling error static deviation
2	1 : Position measurement on load 0 : Position measurement on motor The bit can only be changed, if the position controller's state is STOP
3 ... 15	reserved

See P deviation limiter dynamic (P203) and P deviation limiter static (P212).

The change of position actual value monitoring (bit no. 2) is only possible if controller is disabled. For further notes see function module encoder 1 and encoder 2 as well as encoder manager.

P 202 P Kv factor

The position controller is implemented as P controller. The k_V factor is the gain of the position controller. If $k_V = 0$ the position controller is inactive, because each controller deviation is multiplied with the k_V factor.

P 207 P N precontrol**P 213 P N precontrol smoothing**

The speed precontrol is implemented as DT1 element. Each changes of position set value are differentiated with respect to time, multiplied by parameter N precontrol and then smoothed with the time constant in P213. If N precontrol = 0% the speed precontrol has no effect in the speed set value (P050).

If N precontrol = 100 % and position set value change is constant per time unit, the speed precontrol supplies the exact needed speed set value. The position controller supplies in this case only the correcting set value to follow the angle.

P 220 P N precontrol output

Output value of N precontrol..

Standardization: 100 % ↔ Maximum speed P019

P 211 P controller output

Output value of position controller.

Standardization: 100 % ↔ Maximum speed P019

The speed set value P050 is put together from controller output P211 and the speed precontrol P220.

It is limited to the value in P204. As long as the set value is limited, the bit no. 13 in state P200 is set.

P 208 P set value

The position set value is initialized to the angle of chosen encoder system at first pulse enabling. At further pulse enabling the position actual value (P209) is set.

P 209 P actual value

This parameter displays the position actual value.

Past the first pulse enabling of the controller the position set value is initialized on the resolver or incremental encoder angle after that independent from the actual M desired operation mode (P122) and independent from the status of the state machine (P121) the actual value is permanent actualized

It is possible to write to the position actual value in every operation mode.

Calibration of position set and actual value:

One motor revolution corresponds with internal **65536** increments. The low word represents the motor angle the high word counts the whole revolutions.

P 210 P deviation

The difference between position set value (P208) and actual value (P209) is termed deviation. Reasons for large deviations could be: blocked motor, not achievable set speed or wrong inputs of controller parameters (e.g. speed controller).

The calibration corresponds to the position set/actual value standardization.

P 205 P rev set value

P 206 P phi set value

64 bit position set value. 32 bit for whole revolutions (P205) and 32 bit for angle (P206).

P 218 P rev actual value

P 219 P phi actual value

Copy of 64 bit position actual value from encoder 1 respectively encoder 2 (select P Mode P201 bit no. 2)

P 204 P N limiter bipolar

This parameter limits symmetrically the position control set value (speed set value) . As long as the set value limitation is active, the bit no. 13 in state (P200) is set.

Deviation monitoring

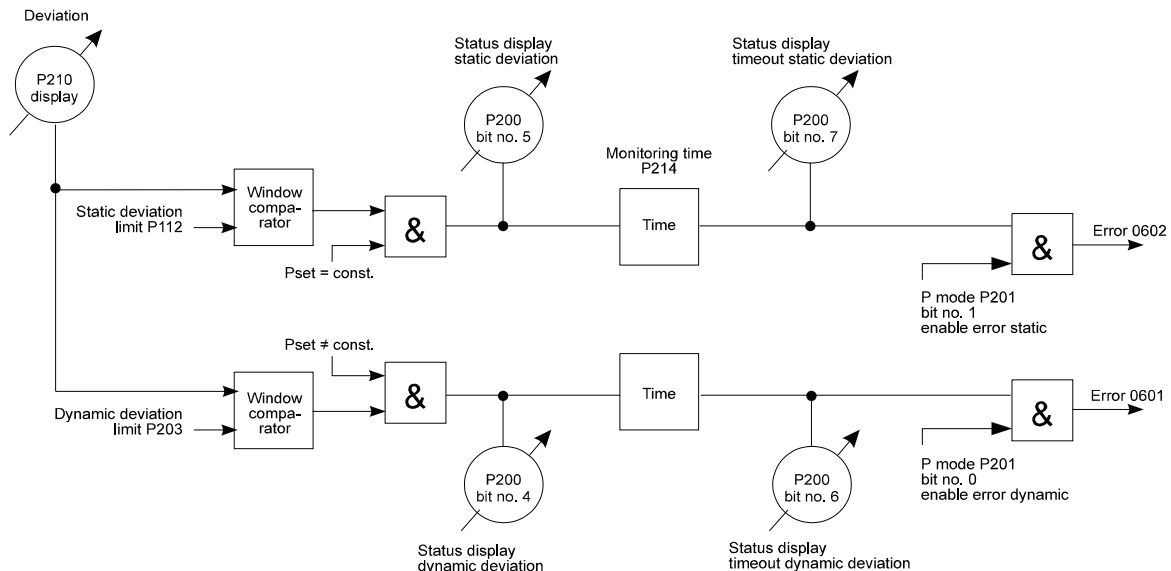

P 212 P deviation limiter static

The static deviation limiter is active, if the position controller no position set value received or the position set value doesn't change (see diagram P203).

The static deviation limiter symmetrically limits the set position value.

If the actual deviation is greater than the entered dynamic deviation limiter, bit no. 5 is set in P state (P200).

After the monitoring time (P time, P214) the bit no. 7 is additionally set and the error code 0602_{hex} (see P124 M error code) is generated. The drive changes to the state inhibit start if in parameter P mode (P201) the error dynamic deviation is enabled (Bit no. 1 = 1).

P 203 P deviation limiter dynamic

The dynamic deviation limiter symmetrically limits the set position value. If the actual deviation greater than the entered dynamic deviation limiter, bit no. 4 is set in P state P200). After the monitoring time (P time, P214) the bit no. 6 is additionally set and the error code 0601_{hex} (see P124 M error code) is generated. The drive changes to the state inhibit start if in parameter P mode (P201) the error dynamic deviation is enabled (bit no. 0 = 1).

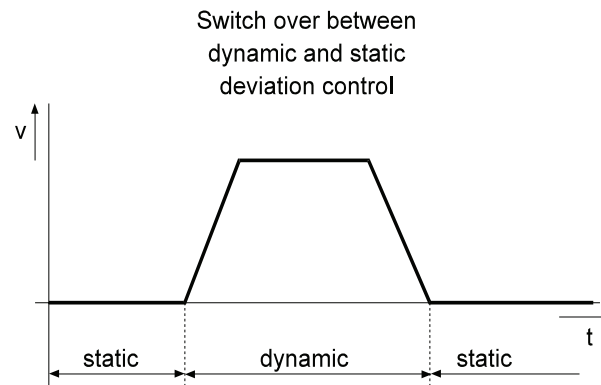
**P 214 P time**

This parameter sets the time window of the deviation monitoring. The delay time is only active, if bit no. 6 and 7 in P state is set.

.Position data formats overview

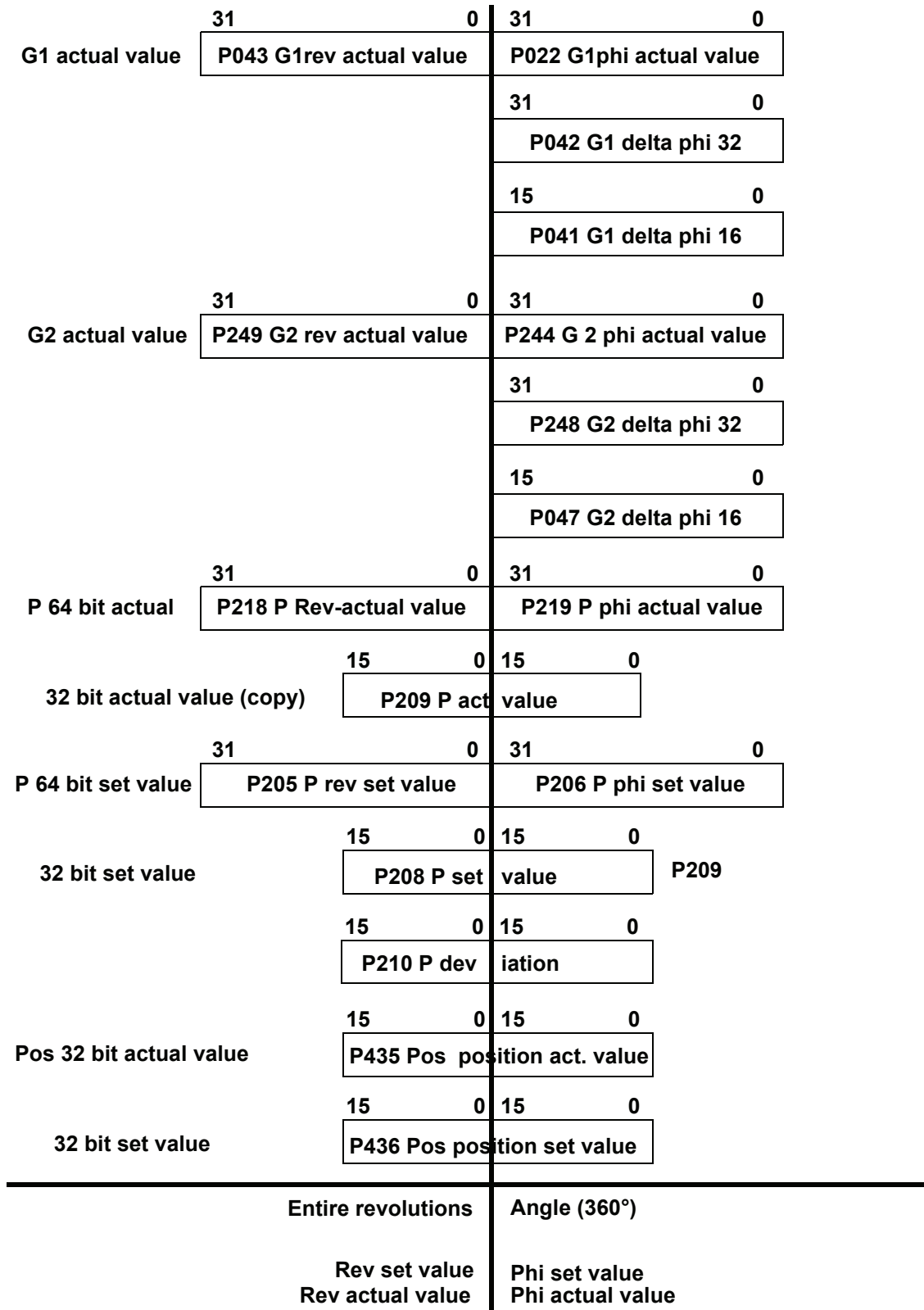

7.15 Drive Manager

Function

The drive manager administrates the essential system resources of the drive. These include among others complete unit control in various modes, switching between the different modes, the management of all communication interfaces, error treatment etc.

Parameter overview

Parameter	Name	Range min. ... max.	Unit	Display only
P120	M control word	0000 ... FFFF		
P121	M state word	0000 ... FFFF		×
P122	M desired operation mode	-5 ... 6		
P123	M actual operation mode	-5 ... 6		×
P124	M error code	0000 ... FFFF		×
P125	M error index	0 ... 31		×
P136	M mode	0000 ... 0001		
P126	M communication source	0000 ... 000F		
P127	M communication monitoring	0000 ... 000F		
P128	M monitoring time	0 ... 60 000	ms	
P129	M monitoring code	-2 ... 3		
P130	M HALT code	0 ... 4		
P131	M RAPID HALT code	0 ... 4		
P132	M INHIBIT no. code	0 ... 4		
P133	M SHUTDOWN code	0 ... 4		
P134	M state bit no. 14	0000 ... FFFF		×
P135	M state bit no. 15	0000 ... FFFF		×
P137	M state 1	0000 ... FFFF		×

- Introduction to the representation of unit control

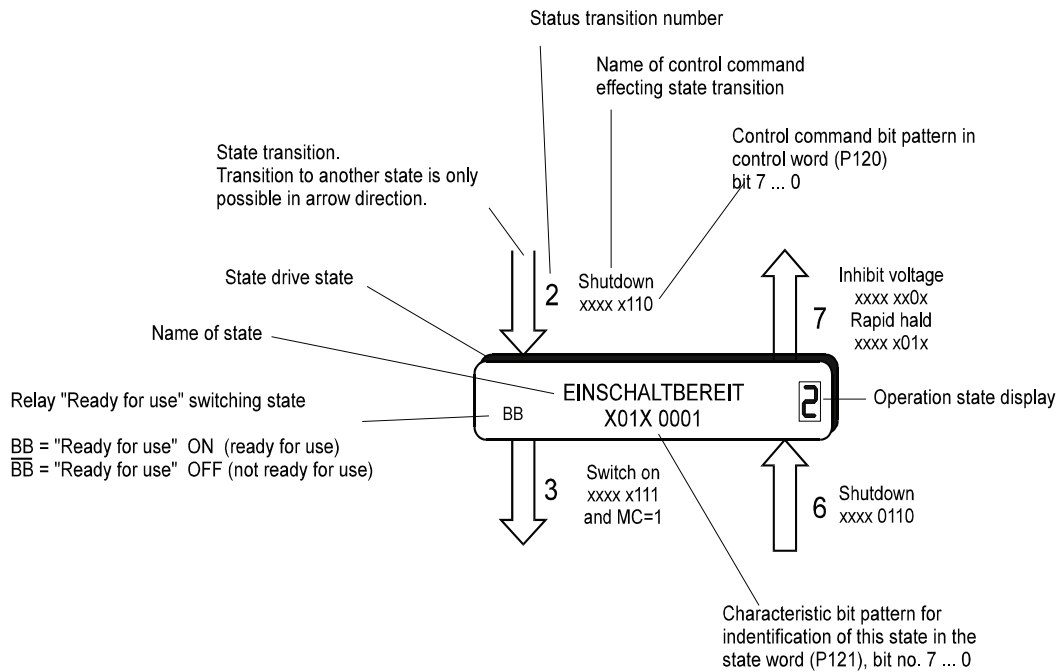

The binary bits 7 ... 0 of the static drive state (P121) are figured XXXX XXXX. The state transition bit pattern of the control word (P120) is figured xxxx xxxx (bit no. 7 ... 0).

The bits designated with X or x have no effect on the unit state.

• Unit control state machine

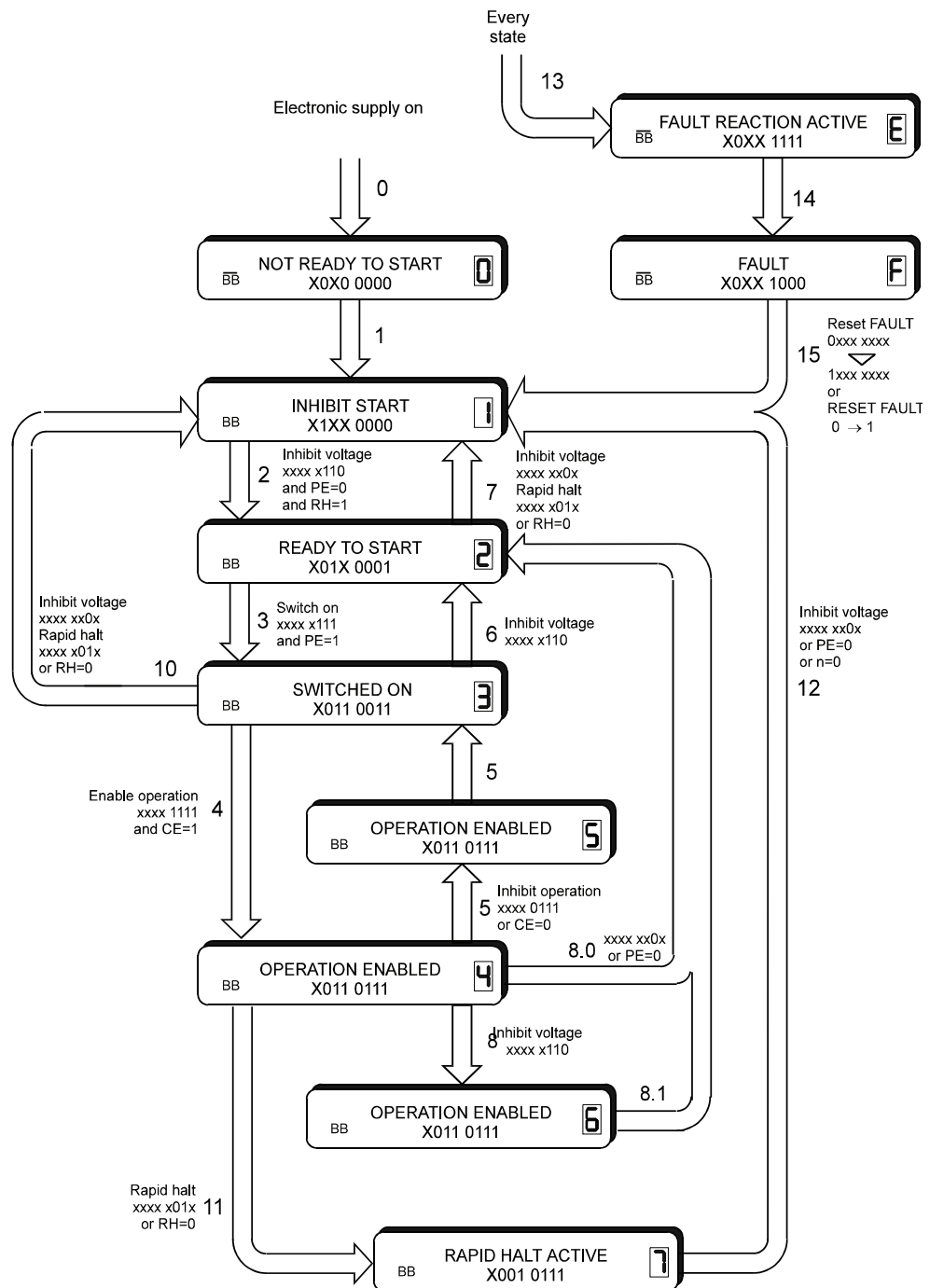

PE = 1: Pulse enabling (X26:14 = High)
 PE = 0: Pulse enabling (X26:14 = Low)

RH = 1: Rapid halt inactive (X26:19 = High)
 RH = 0: Rapid halt active (X26:19 = Low)

CE = 1: CONTROLLER ENABLING high
 CE = 0: CONTROLLER ENABLING low

- **Unit control states**

0 NOT READY TO START

- electronics supplied with voltage
- self-test running
- initialisation running
- drive function inhibited
- relay „ready for use“ is off (drive not ready for use)

1 INHIBIT START

- software/hardware initialisation completed
- parameter assignment completed
- drive function inhibited
- switch-on inhibited
- relay „ready for use“ is on (drive ready for use)

2 READY TO START

- application parameters can be redefined
- drive function inhibited
- switch-on enabled
- relay „ready for use“ is on (drive ready for use)

3 SWITCHED ON

- application parameters can be redefined
- drive function inhibited
- power unit ready for use
- relay „ready for use“ is on (drive ready for use)

4 ENABLE OPERATION

- application parameters can be redefined
- drive function enabled
- relay „ready for use“ is on (drive ready for use)

5 OPERATION ENABLED

- application parameters can be redefined
- drive function enabled
- command „Inhibit operation“ is active (can be set in M shutdown code P132)
- relay „ready for use“ is on (drive ready for use)

6 OPERATION ENABLED

- application parameters can be redefined
- drive function enabled
- command „Shutdown“ is active (can be set in M shutdown code P132)
- relay „ready for use“ is on (drive ready for use)

7 RAPID HALT ACTIVE

- application parameters can be redefined
- rapid halt function is carried out (parameter assignment via M rapid halt code, P131)
- drive function enabled
- relay „ready for use“ is on (drive ready for use)

E FAULT REACTION ACTIVE

- application parameters can be redefined
- an fault-dependant action is carried out
- drive function may be enabled

F FAULT

- application parameters can be redefined
- drive function inhibited
- relay „ready for use“ is off (drive not ready for use)

- **Unit control state transitions**

<p>0 State machine input</p> <p>event:</p> <p style="text-align: center;">or</p> <p style="text-align: center;">or</p> <p>action:</p>	<p>→ NOT READY TO START 0</p>	<ul style="list-style-type: none"> - hardware reset - software reset - switch on operating voltage - switch off relay „ready for use“ - start self-test
<p>1 NOT READY TO START</p> <p>event:</p> <p>action:</p>	<p>0</p>	<p>→ INHIBIT START 1</p> <ul style="list-style-type: none"> - error-free completion of initialisation and self-test - activate communication and process data monitoring - switch on relay „ready for use“
<p>2 INHIBIT START</p> <p>event:</p> <p>condition:</p> <p>action:</p>	<p>1</p>	<p>→ READY TO START 2</p> <ul style="list-style-type: none"> - command „shutdown“ - rapid halt input X26:13 = high - none
<p>3 READY TO START</p> <p>event:</p> <p>condition:</p> <p>action:</p>	<p>2</p>	<p>→ SWITCHED ON 3</p> <ul style="list-style-type: none"> - command „switch on“ - rapid halt input X26:13 = high - switch on power unit, if not on yet - monitoring „ready for use“ signal of power supply
<p>4 SWITCHED ON</p> <p>event:</p> <p>condition:</p> <p>action:</p>	<p>3</p>	<p>→ OPERATION ENABLED 4</p> <ul style="list-style-type: none"> - command „enable function“ - CONTROLLER ENABLING input = high - enable drive function
<p>5 OPERATION ENABLED</p> <p>event:</p> <p style="text-align: center;">or</p> <p>action:</p>	<p>4</p>	<p>→ SWITCHED ON 3</p> <ul style="list-style-type: none"> - command „inhibit operation“ - CONTROLLER ENABLING input = low - inhibit drive function
<p>6 SWITCHED ON</p> <p>event:</p> <p>action:</p>	<p>3</p>	<p>→ READY TO START 2</p> <ul style="list-style-type: none"> - command „shutdown“ - pulse enabling input X26:14 = low - the power unit can be switched off - monitoring „ready for use“ signal of power supply is switched off
<p>7 READY TO START</p> <p>event:</p> <p style="text-align: center;">or</p> <p style="text-align: center;">or</p> <p>action:</p>	<p>2</p>	<p>→ INHIBIT START 1</p> <ul style="list-style-type: none"> - command „rapid halt“ - command „inhibit voltage“ - rapid halt input X26:19=low - none

8.1 OPERATION ENABLED	4	→ READY TO START 2
event:		- command „shutdown“
action:		- inhibit drive function (parameter assignment via M shutdown code P133)
		- the power unit can be switched off
		- monitoring „ready for use“ signal of power supply is switched off
8.2 OPERATION ENABLED	4	→ READY TO START 2
event:		- command „inhibit voltage“
	or	- pulse enabling input X26:14 = low
action:		- shutdown drive function
		- the power unit can be switched off
		- monitoring „ready for use“ signal of power supply is switched off
10 SWITCHED ON	3	→ INHIBIT START 1
event:		- command „inhibit voltage“
	or	- command „rapid halt“
	or	- rapid halt input X26:19=low
action:		- power unit can be switched off
11 OPERATION ENABLED	4	→ RAPID HALT ACTIVE 7
event:		- command „rapid halt“
	or	- rapid halt input X26:19=low
action:		- trigger rapid halt function
12 RAPID HALT ACTIVE	7	→ INHIBIT START 1
event:		- command „inhibit voltage“
	or	- rapid halt completed (n=0)
	or	- pulse enabling input X26:14 = low
action:		- inhibit drive function
		- power unit can be switched off
		- monitoring „ready for use“ signal of power supply is switched off
13 all state types		→ FAULT REACTION ACTIVE E
event:		- drive fault detected
action:		- „ready for use“ relay is switched off
		- trigger error-dependant fault reaction
14 FAULT REACTION ACTIVE	E	→ FAULT F
event:		- fault reaction completed
action:		- inhibit drive function
		- monitoring „ready for use“ signal of power supply is switched off
		- power unit can be switched off
15 FAULT	F	→ INHIBIT START 1
event:		- command „reset fault“
	or	- RESET ERROR input = low → high
condition:		- error no longer present
action:		- fault reset is carried out
		- switch on „ready for use“ relay

The status only changes if all the actions have been carried out. The sequence of actions corresponds to the sequence of processing during status change. After carrying out all the actions the next status is reached, and new commands are accepted.

- **„Ready for use“ relay**

The state of the relay „ready for use“ changes on the following control transitions:

Transition	Action „ready for use“ relay	Comment
0	switch off	start of drive initialisation
1	switch on	end of drive initialisation
13	switch off	error occurred
15	switch on	all errors are acknowledged, drive without faults

State	„Ready for use“ relay
NOT READY TO START	OFF
INHIBIT START	ON
READY TO START	ON
SWITCHED ON	ON
OPERATION ENABLED	ON
RAPID HALT ACTIVE	ON
FAULT REACTION ACTIVE	OFF
FAULT	OFF

- **Monitoring „ready for use“ signal power supply**

The monitoring state is changed only at following states.

Transition	Action	Comment
3	switch on	The time to load the intermediate circuit is considered internally
6 8 9 10 12, 13	switch off	

State	„Ready for use“ relay
NOT READY TO START	OFF
INHIBIT START	OFF
READY TO START	OFF
SWITCHED ON	ON
OPERATION ENABLED	ON
RAPID HALT ACTIVE	ON
FAULT REACTION ACTIVE	OFF
FAULT	OFF

P 120 M control word

This parameter corresponds to DRIVECOM object 6040_{hex} and is the input word of the control unit state machine.

Bit no.	Name	Comment
0	switch on	unit control state machine
1	inhibit voltage	unit control state machine
2	rapid halt	unit control state machine
3	enable operation	unit control state machine
4, 5, 6	mode-dependant	see table „total overview of control words“
7	reset fault	unit control state machine
8, 9, 10	reserved	must always be set = 0
11, 12, 13, 14	mode-dependant	see table „total overview of control words“
15	write protection	

The drive managers control word is write protected if the write protection bit (bit no. 15) is set in the control word. After the processing of the write protected control word the drive manager resets the write protection bit to 0.



NOTE

The controller can reach the state „operation enabled“ immediately after the switch on of the electronic power supply, if the control word (see function module drive manager) is manipulated by digital inputs (see function module digital inputs) and the hardware enable is active. During the programming of digital inputs this option must be considered and protective measures have to be ensured on machine-side.

The write protection must be used if the control word is manipulated by digital inputs and a communication source writes simultaneously on the control word.

The unit control commands are defined in the control word via the following bit combinations:

Command	Bit no. 15 write protection	Bit no. 7 reset fault	Bit no. 3 operation enabled	Bit no. 2 * rapid halt	Bit no. 1 * inhibit voltage	Bit no. 0 switch on	Transitions
Shutdown	×	×	×	1	1	0	2,6,8
Switch on	×	×	×	1	1	1	3
Inhibit voltage	×	×	×	×	0	×	7,9,10,12
Rapid halt	1	×	×	0	1	×	7,10,11
Inhibit operation	×	×	0	1	1	1	5
Enable operation	×	×	1	1	1	1	4
Reset fault	×	0 → 1	×	×	×	×	15
Enable operation straight	1	×	1	1	1	1	2

The bits designated with × have no effect on the unit control state.

* low active

Control word: total overview for all modes

Bit no.	Locating position -1	Current control -2	Speed control -3	Speed specification 1 2	Position control -4	Manual mode 5	Synchronisation control -5	Reference run mode 6	Target position specification 1
0	SWITCH ON (state machine)								
1	INHIBIT VOLTAGE (state machine) *								
2	RAPID HALT (state machine) *								
3	ENABLE OPERATION (state machine)								
4	×	×	RFG inhibit	RFG- * inhibit	×	×	×	starting reference run	new set value
5	×	×	RFG stop	RFG * stop	×	×	×	×	×
6	×	×	RFG-zero	RFG * zero	×	×	×	×	×
7	reset fault (state machine)								
8	×	×	×	×	×	×	×	×	×
9	×	×	×	×	×	×	×	×	×
10	×	×	×	×	×	×	×	×	×
11	×	×	×	×	×	inching forward	×	×	start of positioning
12	×	×	×	×	×	inching backwards	×	×	×
13	×	×	×	×	×	×	×	×	×
14	×	×	×	×	×	×	×	×	×
15	write protection								

The bits designated with × have no effect on the unit control state.

 * low active

P 121 M state word

This parameter corresponds to DRIVECOM object 6041_{hex} and is the output word of the unit control state machine.

Bit no.	Name	Comment
0	READY TO START	state machine
1	SWITCHED ON	state machine
2	OPERATION ENABLED	state machine
3	FAULT	state machine
4	INHIBIT VOLTAGE	bit no. 4 = 0: The „inhibit voltage“ requirement is present (command or main contactor contact)
5	RAPID HALT	state machine
6	INHIBIT START	state machine
7, 8	reserved	reserved
9	remote	bit no. 9 = 1: Parameter can be assigned via the selected communication source
10	set value reached	bit no. 10 = 1: Depending on the active mode it is indicated whether the present set value is reached.
11	reserved	reserved
12, 13	mode dependant	see table „total overview for all modes“
14, 15	state bits	see P134, P135

The unit state is represented by the following bit combinations in the state word:

	Bit in state word						
	State of the unit control	Bit no. 6 INHIBIT START	Bit no.5 * RAPID HALT	Bit no. 3 FAULT	Bit no. 2 OPERA- TION ENA- BLED	Bit no. 1 SWITCHE D ON	Bit no. 0 READY TO START
0	NOT READY TO START	0	×	0	0	0	0
1	INHIBIT START	1	×	0	0	0	0
2	READY TO START	0	1	0	0	0	1
3	SWITCHED ON	0	1	0	0	1	1
4	OPERATION ENABLED	0	1	0	1	1	1
F	FAULT	0	×	1	0	0	0
E	FAULT REACTION ACTIVE	0	×	1	1	1	1
7	RAPID HALT ACTIVE	0	0	0	1	1	1

The bits designated with × have no effect on the unit control state.

 * low active

Parameter

State word: total overview for all modes

Bit no.	Locating position -1	Current control -2	Speed control -3	Speed specification 1 2	Position control -4	Manual mode 5	Synchronisation control -5	Reference run mode 6	Target position specification 1 1
0	READY TO START (state machine)								
1	SWITCHED ON (state machine)								
2	ENABLE OPERATION (state machine)								
3	FAULT (state machine)								
4	VOLTAGE INHIBITED (state machine) *								
5	RAPID HALT (state machine) *								
6	INHIBIT START (state machine)								
7	×	×	×	×	×	×	×	×	×
8	×	×	×	×	×	×	×	×	×
9	remote								
10	×	×	set value speed set value	reached speed set value	position set value	×	position set value	reference speed	position reached
11	×	×	×	×	×	×	×	×	×
12	×	×	×	×	×	×	×	reference run fin- ished	set value acknowl- edgement
13	×	×	×	×	×	×	×	reference run error	×
14	state bit see P134, M state bit 14								
15	state bit see P135, M state bit 15								

The bits designed with × are reserved and have to be set 0.

 * low active

Bit no. 10: „set value reached“ is actualised only in state OPERATION ENABLED.

P 122 M desired operation mode

This parameter corresponds to DRIVECOM object 6060_{hex} and specifies the mode for the drive.

Selection code	Mode	Comment
-5	Synchronisation control	optional
-4	Position control	standard
-3	Speed control	standard
-2	Current control	standard
-1	Locating position reference point setting	standard
1	Target position specification	optional
2	Speed specification 1	standard
5	Manual mode	optional
6	Reference run mode	optional

The operation modes can be changed with controller disabled (off-line), but partly with enabled controller (on-line).

See table M actual mode (P123), too.

P 123 M actual operation mode

This parameter corresponds to DRIVECOM object 6061_{hex} and indicates the currently active drive mode (see also set mode table).

For switching from the current mode to the desired actual mode the following schematic diagram applies:

Mode switching

Mode switching	-5	-4	-3	-2	from -1	2	6	5	1
to	Syn-chroni-sation control	Posi-tion control	Speed control	Current control	Locat-ing position	speed speci-fication 1	Refer-ence run mode	Manual mode	Target position speci-fication
Synchronisa-tion control	×	2	2	2	1	2	2	2	2
Position con-trol	2	×	2	2	1	2	2	2	2
Speed con-trol	2	2	×	2	1	2	2	2	2
Current con-trol	2	2	2	×	1	2	2	2	2
Locating position	1	1	1	2	×	1	1	1	1
speed speci-fication 1	2	2	2	2	1	×	2	2	2
Reference run mode	2	2	2	2	1	2	×	2	2
Manual mode	2	2	2	2	1	2	2	×	2
Target posi-tion speci-fication	2	2	2	2	1	2	2	2	×

When 1

mode switching is only possible off-line in the INHIBIT START, READY TO START and SWITCHED ON state types.

When 2

mode switching is possible off-line in the INHIBIT START, READY TO START and SWITCHED ON state type as well as on-line in the OPERATION ENABLED state.



NOTE

Switching to possibly non-implemented optional modes is not prevented.

P 124 M error code

In case of a fault, the corresponding error code can be found here. This error is acknowledged if the bit „reset fault“ in the control word (P120) is set from 0 to 1 or the input "error reset" is enabled (see P136 M mode).

If several errors are present, the next error is displayed immediately after acknowledgement. Error codes see chapter maintenance, error messages.

P 125 M error index

This parameter indicates the number of errors which are present. On acknowledgement of each error the displayed value is decreased. The parameter contains the number 0 after acknowledging all errors.

P 136 M mode

This parameter chooses the different options to acknowledge an error message (see connection of function inputs in chapter installation).

P 126 M communication source

The access rights of the various sources of communication are managed via this parameter. Sources of communication are all program modules which exchange data with a master control via a communication protocol. As several of these program modules can be implemented in the drive, but not all modules can have simultaneous access to all parameters (particularly the drive manager's status word P120), write-access must be managed correspondingly.

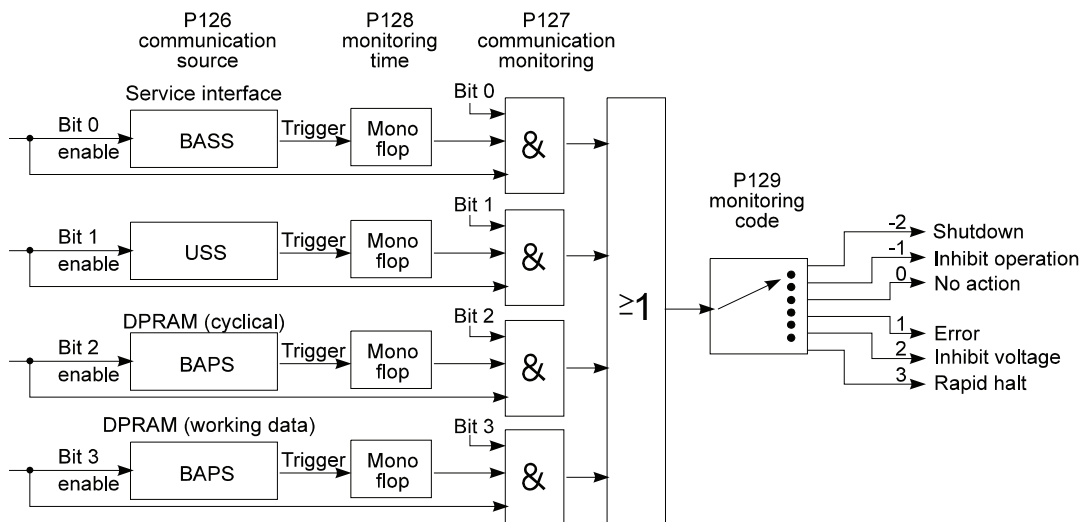

Depending on the parameter „communication source“ the drive manager activates and deactivates the various communication modules. Each communication module has a state parameter where the current state (RUN/STOP) is displayed.

A communication module is only allowed to write-access drive parameters when in the RUN status. In the STOP status no write-access is allowed. Reading the drive parameters is possible in any state.

The parameters M communication source (P126) and DSM command (P190) can be changed always with service interface and dual port RAM interface (BASS protocol, operation program).

According to the unit configuration, the following sources of communication are possible:

Bit no.	Meaning
0	1: BASS protocol via RS 232 enabled
1	1: USS protocol via RS 485 enabled
2	1: dual port RAM (cyclic data)
3	1: dual port RAM (working data)
4 ... 15	reserved

If the parameter „communication source“ is set to 0, the drive can only be controlled via pulse enabling (PE), rapid halt (RH) and CONTROLLER ENABLING. As no master control is available, the drive manager itself can set the corresponding control commands.

P 127 M communication monitoring

Monitoring of the sources of communication can be activated via this parameter.

Bit no.	Meaning
0	1: BASS protocol via RS 232 enabled
1	1: USS protocol via RS 485 is enabled
2	1: dual port RAM (cyclic data)
3	1: dual port RAM (working data)
4 ... 15	reserved

P 128 M monitoring time

This parameter sets the time constant of communication monitoring. It is valid for all sources of communication.

If no information from the current communication source is received within the period set in the parameter „monitoring time“, e.g. as a result of an open circuit on an interface cable or defective communication card, the action selected in the parameter „monitoring selection code“ is carried out. Monitoring time can be up to one minute with the representation unit being 1 ms. If the time 0 ms is entered, monitoring is switched off.

If the controller is operated without communication (P126 = 0), monitoring time must be set to 0 ms.

P 129 M monitoring code

This parameter corresponds to DRIVECOM object 6004_{hex} and determines the drive reaction in the event of the communication monitoring time being exceeded. It is not important which communication source caused the timeout.

Selection mode	Function
-2	command SHUTDOWN is updated
-1	command INHIBIT OPERATION is updated
0	no action
1	transition to fault state
2	command INHIBIT VOLTAGE is updated
3	command RAPID HALT is updated

P 130 M HALT code

This parameter corresponds to DRIVECOM object 605D_{hex} and determines the drive reaction in the unit control state machine in the OPERATION_ENABLED status. The HALT function is only implemented in the speed control and speed specification 1 modes.

Depending on control bit no. 4 „inhibit RFG“ the HALT function selected by the HALT code is carried out.

Code	Function
0	inhibit drive function
1	shutdown procedure at ramp-down ramp of ramp function generator
2	shutdown procedure at RAPID HALT ramp (set at P009)
3	shutdown procedure at current limit

P 131 M RAPID HALT code

This parameter corresponds to DRIVECOM object 605A_{hex} and determines the drive reaction in the unit control state machine in the RAPID HALT ACTIVE state.

Code	Function
0	inhibit drive function
1	shutdown procedure at ramp-down ramp of ramp function generator
2	shutdown procedure at RAPID HALT ramp (set at P009)
3	shutdown procedure at current limit

P 132 M INHIBIT code

This parameter corresponds to DRIVECOM object 605C_{hex} and determines the drive reaction in the unit control state machine during transition 5..

Code	Function
0	inhibit drive function
1	shutdown procedure at ramp-down ramp of ramp function generator
2	shutdown procedure at RAPID HALT ramp (set at P009)
3	shutdown procedure at current limit

P 133 M SHUTDOWN code

This parameter corresponds to DRIVECOM object 605B_{hex} and determines the drive reaction in the unit control state machine during transition 8.

Code	Function
0	inhibit drive function
1	shutdown procedure at ramp-down ramp of ramp function generator
2	shutdown procedure at RAPID HALT ramp (set at P009)
3	shutdown procedure at current limit

P 134 M state bit no. 14

P 135 M state bit no. 15

This parameters guide the bit no. 14 and 15 in state word (P120). From arbitrary 16 bit parameters a single bit can copied to the state word.

Bit no.	Meaning
0... 10	1 .. 2047: no. of parameter, binary code 0 state bit is not updated
11	reserved
12 ... 15	0 ... 15: bit no., binary code

Examples:

- 1.The N=0 signal from encoder 1 (P025, bit no. 19) should be connected with state bit no. 14:
P134 must be set to A019_{hex}.
- 2.Exceeding the dynamic deviation (P200, bit no. 4) should be connected with state bit no. 15.
P135 must be set to 40C8_{hex} .

P 137 M state 1

This parameter displays the state (7-segment display) of the controller.

Bit no.	Meaning
0 ... 3	Shows the state number displayed in the 7 segment display
4 ... 15	Reserve

7.16 Data Set Management

Function

Data set management is a universal module for loading and saving parameters

Data sets can be loaded from EPROM, changed and saved. 4 data sets can be managed at every time.

- **After switching on (booting)**

Directly after switching on the operating voltage supply the DSM (data set management) automatically loads the boot data set (data set 0) into the drive's user memory.

After successful execution of this command the DSM stops in

state 0003: STAND_BY (P191)
message 0000: no error (P192).

If no boot data set has been created yet, the DSM is in

state 000B: STAND_BY with error (P191)
message 0002: data set not available (P192).

In addition to the drive managers state changes to „F“ fault and parameter M error code (P124) displays the error code 0902_{hex}.

- **Creating and updating a boot data set**



NOTE

Prior to any new action the DSM (data set management) must first be reset by the command 0: Re-set (P190)

This measure sets all DSM parameters to value 0. This also refers to data set name (P193) and data set version (P194), which in this state represent the boot data set.

It must now be set via the command 5: write data set into EEPROM (P190) how the boot data set is to be created for the first time in EEPROM or how an existing boot data set is to be updated. ¹⁾

Only in the case of message 0000: no error (P192) and DSM state 0003: STAND_BY is the data set been written correctly.

¹⁾ The counter „DS program cycle“ (P197) is increased by 1.

- **Creating and updating other data sets**

The procedure is identical to that of creating and updating a boot data set except that the parameter data set name (P193) can now be selected from numbers 1 to 3.

Data sets can be transmitted to the working memory with

command 6: read data set from EEPROM (P190).

- Only in the case of DSM message 0000: no error (P192) and DSM state 0003: STAND_BY has the data set been written correctly.

- **Source load of the parameters**

If a source load is carried out the standard values of the parameter list are set and therefore a defined state is reached.

The procedure of the source load is mentioned below:

- 1.P190 = 0command reset data set management
- 2.P190 = 7command delete data set
- 3.Wait until P191 = 0003
- 4.Switch off power supply of controller
- 5.Switch on power supply of controller
- 6.Now is displayed:P191 = 000Bstand-by with error
P192 = 0002 data set not available
P124 = 0902
The controller's state is fault
- 7.P190 = 0command reset data set management
- 8.P190 = 5command store data set
- 9.Wait until P191 = 000B

- **Store the write protected data set**

- 1.P190 = 0command reset data set management
- 2.P190 = 8command input password
- 3.P190 = password 1
- 4.P190 = 0command reset data set management
- 5.P193 = 3DS no. write-protected data set
- 6.P190 = 5command store data set

- **Change article no. of data set**

- 1.P190 = 0command reset data set management
- 2.P190 = 8command input password
- 3.P190 = password 2
- 4.P190 = 0command reset data set management
- 5.P193 = 0, 1, 2, (3)*data set no.
- 6.P194 = new article no.hexadecimal number
- 7.P190 = 5command store data set

* only possible, if password 1 was already given

Overview of the commands

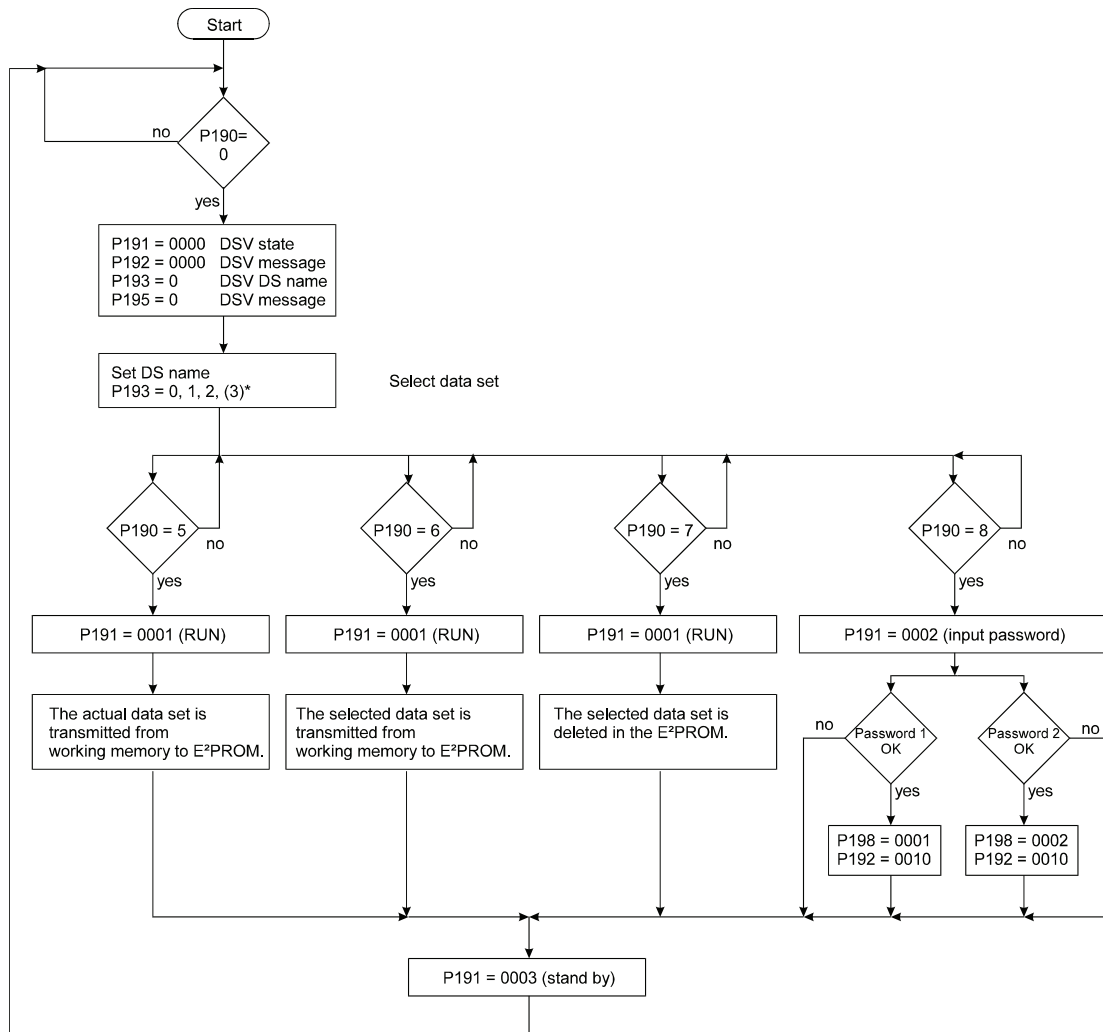

Parameter overview

Parameter	name	Range min. ... max.	Unit	Display only
P190	DSM command	0 ... 8	0	
P191	DSM state	0000 ... FFFF		×
P192	DSM message	0000 ... FFFF		×
P195	DSM message Pxxx	0 ... 700		×
P193	DSM DS name	0 ... 3		
P194	DSM DS article no.	0000 0000 ... FFFF FFFF		×
P197	DSM DS program cycles	0 ... 65536		×
P196	DSM load data set	0 ... 3		
P198	DSV key	0000 ... 0003		×

Parameter description

P 190 DSM command

This command instructs the data set management to load, save or delete an existing data set.

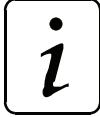

NOTE

This parameter is independent of the parameter M communication source (P126) always changeable.

Command	Meaning
0	reset of data set management The parameter P191 till P195 are set automatically to 0.
5	save data set from user memory to EEPROM
6	load data set from EEPROM to user memory
7	delete EEPROM data set
8	input password

P 191 DSM state

Bit no.	Meaning
0 ... 2	000 : STOP Data set management is ready for a command or for changing data sets. 001 : RUN Data set management is processing a command. 011 : STAND_BY Data set management has finished a command.
3	1 : An error has occurred in the data set management. Error code see P124, M error code and P192, DSM message
4 ... 15	reserved

P 192 DSM message

If a message occurs during the implementation of a command, it is displayed in this parameter.

Bit no.	Meaning
0	1: undefined command
1	1: data set not available
2	1: wrong check sum
3	1: parameter not changeable
4	reserved
5	1: memory full
6	1: error in configuration list
7	1: undefined parameter format

P 195 DSM message Pxxx

If a message has occurred (P192 ≠ 0), this parameter shows the parameter no. involved.

P 193 DSM DS name

A maximum of 4 data sets can be managed in each memory area. They are selected via the parameter „data set name“.

The boot data set is always EEPROM data set 0

Value	Memory range EEPROM (non-volatile)
0	data set 0 (boot data set)
1	data set 1
2	data set 2
3	data set 3 (write-protected data set)

P 194 DSM DS article no.

Article no. of a data set ex factory.

P 197 DSM DS program cycles

Number of write actions on this data set.

P 196 DSM load data set

The data set with the corresponding number (0...2) can be loaded from the EEPROM into the working memory via this parameter.

The following procedure should be adhered to:

- Firstly, ensure that the status of the data set management (P191) is either set to 0 (STOP) or to 0003 (STAND_BY).
- Next enter the number of the required data set in the parameter, P196 (DSM load data set).
- All further steps follow independently:
 - The number of the required data set is displayed in parameter P193.
 - The command 6 „load data set from EEPROM into user memory“ is visible in the parameter P191 (DSM command).
 - The data set is loaded.
- The procedure is completed once the DSM status displays again state 0003 (STAND_BY). (Incidentally entered numbers should be ignored.)

- **Change data set via P196**

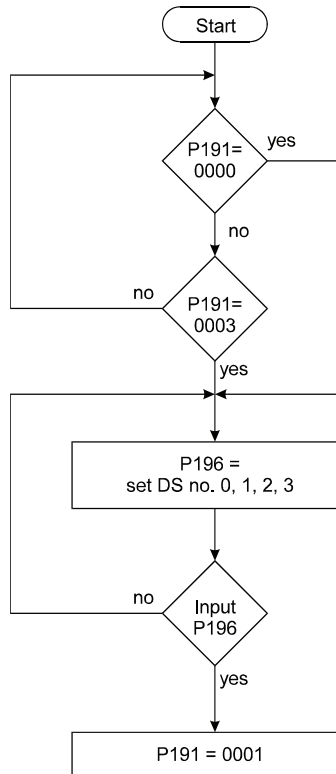

The time in which this procedure is carried out will differ according to the loading of the microprocessor.



NOTE

This parameter can be used to change data sets via digital inputs. A change over must not be executed if controller is enabled!

P 198 DSM key

Bit no.	Meaning
0	0: Data set 3 is write-protected 1: Data set 3 is write-enabled (only after input of password 1)
1	0: The article no. of all data sets is write-protected 1: The article no. of all data sets is write-enabled (only after input of password 2)
2 ... 15	reserved

7.17 Operation System

Parameter overview

Parameter	Name	Range min. ... max.	Unit	Display only
P166	OS state	0000 ... FFFF		
P162	OS message	0 ... 9999		×
P161	OS sampling time	124.8 ... 4000.0	μs	×
P167	OS sync. slot	0 ... 8000	μs	
P168	OS sync. offset	0 ... 8000	μs	
P169	OS sync. tolerance	0.2 ... 80.0	μs	
P174	OS user software	0.00 ... 99.99		×
P163	OS BUS6-VC SW release	0.00 ... 99.99		×
P160	OS selection	0 ... 1000		
P159	OS value	0 ... 65535		

Parameter description

P 166 OS state

This parameter displays the state of the function module operation systems.

Bit no.	Meaning
0 ... 3	1: operation system runs
4	1: controller is synchronized to sync. signal
5 ... 11	reserved
12	1: main program cycle time exceeds maximum value
13	1: task calculation time has exceeded maximum value
14	1: sync. IR calculation time has exceeded maximum value
15	reserved

P 162 OS message

This parameter shows the number of operation system errors.

P 161 OS sampling time

The system clock shows the run interval of the shortest operation system time slot.

P 167 OS sync. slot

Value	Meaning
0	operation system synchronisation is not active
500 μ s	controller synchronisation in 0.5 ms clock time
1000 μ s	controller synchronisation in 1 ms clock time
2000 μ s	controller synchronisation in 2 ms clock time
4000 μ s	controller synchronisation in 4 ms clock time
8000 μ s	controller synchronisation in 8 ms clock time

P 168 OS sync. offset

The synchronisation time point can be moved within the chosen synchronization clock.

P 169 OS sync. tolerance

Within the set tolerance range the sync. signal is allowed to differ from nominal value for a short time.

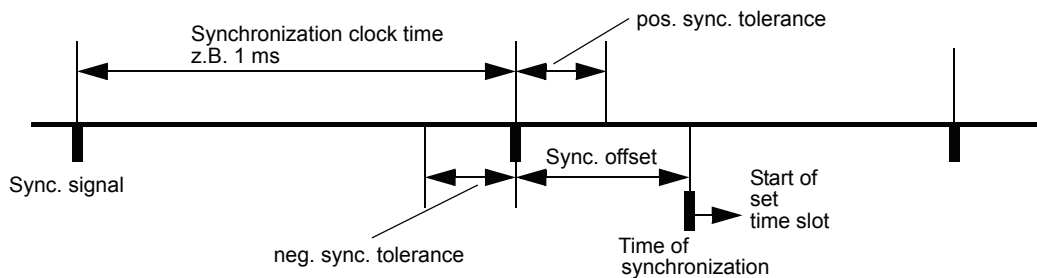

P 174 OS user SW

Value	Meaning
0	production run software
>0	user fitted software

P 163 OS BUS6-VC SW release

This parameter displays the software release of the controller.

P 160 OS selection

P 159 OS value

With this parameter different measured values can be read from operation system.

Selection P160	Value P169	Unit
4	Maximum value of main program cycle time (The maximum value memory can be reset through writing on)	[1 ms]
40	Actual measured values of main program cycle time	[1 ms]
5	16 bit counter for main program cycles	[1]

7.18 Ramp Function Generator

Function:

The ramp function generator (RFG) manages the 4 set value inputs, which can alternatively be switched to the output. The ramp-up and ramp-down times can be set separately for each input.

All inputs and the output of the ramp function generator are relative parameters ($\pm 100\%$) and standardized to maximum speed (P019).

The ramp steepness for the acceleration and braking procedures are determined by the ramp-up and ramp-down times. The times thus refer to 100% set value alteration.

With exception of the fourth set speed value, which is programmed to zero, every input can take speed values between -100% and $+100\%$. 100% corresponds with maximum speed (P019).

The ramp function generator is only active in mode speed control (P122 = -3) and speed precontrol 1 (P122 = 1), as well at the different braking procedures initiated by the drive manager (transitions 5, 8 and 11).

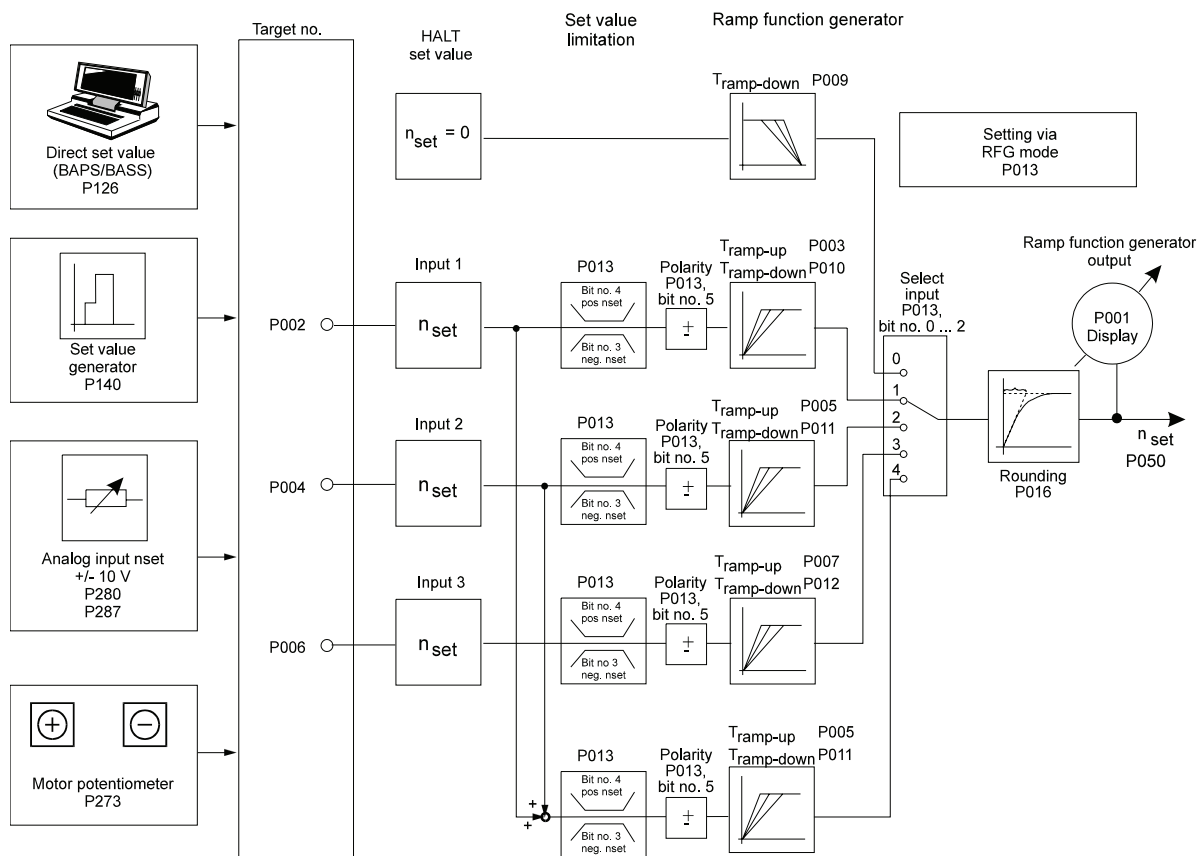

Parameter

Parameter overview:

Parameter	Name	Range min. ... max.	Unit	Display only
P014	RFG state	0000 ... FFFF		×
P013	RFG mode	0000 ... 007F		
P002	RFG input 1	-100.00 ... 100.00	%	
P004	RFG input 2	-100.00 ... 100.00	%	
P006	RFG input 3	-100.00 ... 100.00	%	
P003	RFG ramp-up time 1	0.00 ... 650.00	s	
P010	RFG ramp-down time 1	0.00 ... 650.00	s	
P005	RFG ramp-up time 2	0.00 ... 650.00	s	
P011	RFG ramp-down time 2	0.00 ... 650.00	s	
P007	RFG ramp-up time 3	0.00 ... 650.00	s	
P012	RFG ramp-down time 3	0.00 ... 650.00	s	
P009	RFG time halt	0.000 ... 60.000	s	
P016	RFG rounding	0 ... 60000	ms	
P001	RFG output	-100.00 ... 100.00	%	×

Parameter description

P014 RFG state

Displays the function module's state.

Bit no.	Meaning
0 ... 2	000: STOP 001: RUN
3	1: error in function module, error code see M error code (P124)
4	1: RFG output is set internally to 0 (RFG_LOCKED)
5	1: RFG was stopped on the ramp (RFG_STOP)
6	1: RFG input is set internally to set value 0 (RFG_ZERO)
7	1: rapid-halt ramp is active (RFG_RHALT)
8	1: ramp-up procedure is active
9	1: ramp-down procedure is active
10	See bit no. 5
11	See bit no. 7
12	1: RFG output = RFG input (set value reached)
13 ... 15	reserved

P013 RFG mode

The input selection chooses one out of four inputs of the ramp function generator and activates the set value limitation.

Bit no.	Meaning
0 ... 2	000: halt 001: input 1 010: input 2 011: input 3 100: sum of input 1 and input 2
3	1: negative set values are disabled
4	1: positive set values are disabled
5	1: change polarity of actual set value
6	1: If halt is activated, the motor brakes to speed 0 with set ramp. The controller is active after N = 0.
7 ... 15	reserved

P002 RFG input 1**P004 RFG input 2****P006 RFG input 3**

All 3 inputs are balanced and can be written via the serial interface, position controller and the set value generator as well as the analog set value input.

P003 RFG ramp-up time 1**P005 RFG ramp-up time 2****P007 RFG ramp-up time 3**

The acceleration assigned to the inputs can be set via the ramp-up times. The time selected here correspond to a set value alteration of 100 %.

P010 RFG ramp-down time 1**P011 RFG ramp-down time 2****P012 RFG ramp-down time 3****P009 RFG time halt**

The deceleration assigned to the inputs can be set via the ramp-down times. The time selected here correspond to a set value alteration of 100 %.

P016 RFG rounding

A first-order time delay element is implemented in order to round off ramp corners. The time constants of the PT₁ device can be set by this parameter.

P001 RFG output

This parameter displays the actual output value.

7.19 Set Value Generator

Function

The module creates a plateau set value for each of the 4 time zones. Both the plateau amplitude and the output time interval per zone can be allocated parameters. The amplitudes are relative and are standardised by means of the min./max. receiver values. On termination of the last time zone the first time zone starts again. Each time the controller is enabled the set value generator is newly started in zone 1. When leaving the state „operation enabled“ (P121), the set value generator is stopped.

Thus e.g. the following speed set value graph can be created:

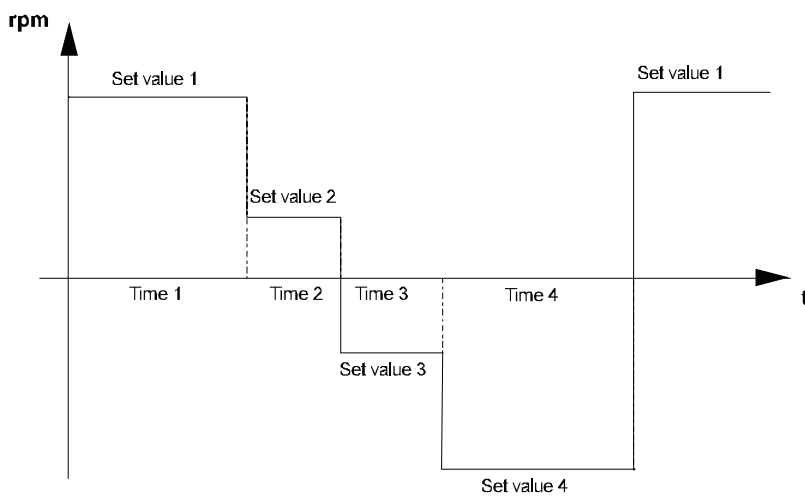

Parameter overview

Parameter	Name	Range		Unit	Display only
		min.	... max.		
P150	SVG state	0000	... FFFF		×
P140	SVG target Pxxx	0	... 700		
P141	SVG output	- 100.00	... + 100.00	%	×
P142	SVG set value 1	- 100.00	... + 100.00	%	
P143	SVG set value 2	- 100.00	... + 100.00	%	
P144	SVG set value 3	- 100.00	... + 100.00	%	
P145	SVG set value 4	- 100.00	... + 100.00	%	
P146	SVG time 1	0.001	... 60.000	s	
P147	SVG time 2	0.001	... 60.000	s	
P148	SVG time 3	0.001	... 60.000	s	
P149	SVG time 4	0.001	... 60.000	s	

Parameter description

P 150 SVG state

This parameter displays the internal function module state.

Bit no.	Meaning
0 ... 2	000: STOP 001: RUN
3 ... 15	reserved

P 140 SVG target Pxxx

To this parameter no. the output value is written (e.g. parameter P002, input 1 ramp function generator).

P 141 SVG output value

The actual set value is displayed here.

P 142 SVG set value 1

P 143 SVG set value 2

P 144 SVG set value 3

P 145 SVG set value 4

Parameter values between -100 % and +100 % can be assigned to these 4-amplitude-parameters. The amplitudes are connected to the output value according to the time assigned to them.

P 146 SVG time 1

P 147 SVG time 2

P 148 SVG time 3

P 149 SVG time 4

Values between 8 ms and 60 s can be assigned to these time parameters. The corresponding amplitudes are switched to the output value during these time intervals.

7.20 Motor Potentiometer

Function

The motor potentiometer allows the alteration of all parameter values which can be written via the function inputs. Therefore it is necessary to program two digital inputs on the parameter EA motor potentiometer + (P271) and EA motor potentiometer - (P272).

The cycle time of the function module is 32 ms.

Parameter overview

Parameter	Name	Range min. ... max.	Unit	Display only
P270	EA mode	0 ... 1		
P271	EA motor potentiometer +	0 ... 1		
P272	EA motor potentiometer -	0 ... 1		
P273	EA motor potentiometer Pxxx	0 ... 700		
P274	EA motor potentiometer dynamics	0 ... 2		
P275	EA motor potentiometer increment	0.01 ...20.00	%	
P276	EA motor potentiometer value	- 100.00 ... + 100.00	%	×

Parameter description

P270 EA mode

Value	Meaning
0	no function
1	motor potentiometer function active

P271 EA motor potentiometer +

Value	Meaning
0	inching + off
1	inching + on („motor potentiometer output value“ is increased)

P 2 72 EA motor potentiometer -

Value	Meaning
0	inching - off
1	inching - on („motor potentiometer output value“ is decreased)

**NOTE**

The motor potentiometer output value is not changed, if EA motor potentiometer + and EA motor potentiometer - equal 1.

P 2 73 EA motor potentiometer Pxxx

The inching function target Pxxx serves to specify the receiver address (= target parameter) of the output value, e.g. input ramp function generator.

**NOTE**

No target parameter number check is carried out.

P 2 74 EA motor potentiometer dynamics

The setting dynamics for key operation can be set here.

Value	Meaning
0	Step-by-step increment, on every LO/HI transition the output value is changed by the value „increment“ with the correct polarity
1	Linear increment, during the HI signal the output value is changed by the value „increment“ at every cycle
2	Square-law increment, during the HI signal the output value is changed with the right polarity at every cycle with square-law „increment“

P 2 75 EA motor potentiometer increment

The value by which the output value is altered on key operation can be set via this parameter.

P 2 76 EA motor potentiometer value

This parameter describes the inching function module output.

7.21 Synchronisation Control

Parameter overview

Parameter	Name	Range min. ... max.	Unit	Display only
P250	SC state	0000 ... FFFF		×
P251	SC mode	0000 ... 0013		
P255	SC following axis rpm	-30000 ... +30000		
P256	SC leading axis rpm	1 ... 30000		
P252	SC compensation factor	1 ... 1000		
P253	SC tolerance	0020 ... 7FFF	Inc	
P257	SC position set value	00000000 ... FFFFFFFF		
P258	SC phi set value	00000000 ... FFFFFFFF		
P254	SC sync. delta	80000001 ... 7FFFFFFF		
P259	SC tolerance time	0.000 ... 60.000	s	
P324	SC N P gain	0.1 ... 1000.0		
P325	SC N integral action time	1.0 ... 2000.0	ms	
P323	SC d_ref 0	0000 ... FFFF	Ink	

Parameter description

P250 SC state

This parameter gives the state of the synchronisation control..

Bit no.	Meaning
0 ... 3	0: STOP synchronisation control switched off 1: RUN synchronisation control active
4	1: synchronisation is finished (only in mode synchronisation, P251 = 2)
5	1: The reference run to zero impulse of the leading axis has set tolerance threshold reached. (only in mode reference run to zero impulse P251 = 1)
6	1: reference run to zero impulse of leading axis is finished (only in mode reference run to zero impulse P251 = 1)
7	reserved
8	1: synchronous set value is initialized (only in mode set synchronous set value)
9	1: an actual synchronous set value available
10	0: synchronous interpolation active 1: synchronous extrapolation active
11 ... 15	reserved

P 2 5 1 SC mode

Bit no.	Meaning
0 ... 3	0000: speed synchronisation control or relative angle synchronisation control 0001: absolute angle synchronisation control 0010: reserved 0011: synchronisation control with synchronous set value
4	0: transparent mode: all alternations take immediate effect 1: The parameter following axis rpm and leading axis rpm can be changed. The transmission ratio remains unaltered. 1→0: The altered leading/following axis rpm parameters are taken over simultaneously.
5 ... 15	reserved

P 2 5 5 SC following axis rpm

Numerator of the quotient which determines the transmission ratio in the electronic gearing.

P 2 5 6 SC leading axis rpm

Denominator of the quotient which determines the transmission ratio in the electronic gearing. The transmission ratio of the electronic gearing is calculated according to the following equation:

$$i = \frac{\text{Following axis rpm}}{\text{Leading axis rpm}} = \frac{P255}{P256}$$

Denominator and numerator of transmission ratio are integers. The numerator can be negative, too.

Several transmission ratios and their respective parameter values are displayed in the following table.

i	Leading axis rpm	Following axis rpm
0.2	10	2
- 0.78	- 100	78
1.15	100	115
9.452	1000	9452
0.3333	10	3

Parameter

Example:

Change transmission ratio from 0.8 to 1.15

edit mode = 0 (transparent mode)

leading axis rpm	following axis rpm	edit mode	transmission ratio i
10	8	0	0.8
10 → 100	8	0	0.8 → 0.08
100	8 → 115	0	0.08 → 1.15

or

leading axis rpm	following axis rpm	edit mode	transmission ratio i
10	8	0	0.8
10	8 → 115	0	0.8 → 11.5
10 → 100	115	0	11.5 → 1.15



NOTE

The transparent mode can lead to undesired transmission ratios!

edit mode = 1

leading axis rpm	following axis rpm	edit mode	transmission ratio i
10	8	0	0.8
10	8	0 → 1	0.8
10 → 100	8	1	0.8
100	8 → 115	1	0.8
100	115	1 → 0	1.15

Undesired transmission ratios do not appear with edit mode = 1!

P 2 5 7 SC position set value

P 2 5 8 SC phi set value

These parameter are used in operation mode „synchronisation control with synchronous set value setting“ as set value inputs.

Standardization:

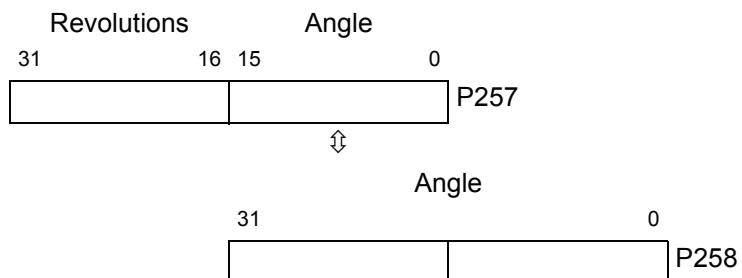

P 2 5 4 SC sync delta**P 2 5 2** SC compensation factor

In operation mode „absolute angle synchronisation“ this parameter sets the compensation speed.

P 2 5 3 SC tolerance**P 2 5 9** SC tolerance time

In operation mode „absolute angle synchronisation“ these parameters set the tolerance threshold and the delay time to enable state bit no. 5..

Standardization: 1 ↔ 1 encoder increment

**Description of Synchronous Operating Modes**

- Mode 0, synchronous operation (standard function)

If the drive controller is enabled in mode synchronous operation with electronic transmission or switched online to this mode, the system uses the position actual values of the leading axis and of the position controller, which are valid at this time, as the basis of calculation for the electronic transmission. This means that from this time onwards, the rotating shaft (leading axis) and the motor (following axis) have a fixed, non-defined angular relationship with one another.

During operation, the system multiplies all the leading axis position changes by the transmission factor $i = \frac{P255}{P256}$ and transfers them to the position controller.

In the case of a controller inhibit or a change to the other operating mode, the angular relationship, which may exist between the leading and following axis, is lost.

- Mode 1, synchronous operation with reference run to the leading axis's zero pulse



NOTE

Incremental encoders with an identical number of increments must be present on the leading and following axis.

Each time the controller is enabled or switched online to this operating mode, the system synchronizes the following axis's zero pulse to the leading axis's zero pulse. This is only possible when the leading axis is rotating.

On conclusion of the synchronization procedure, the system sets bit number 5 in GL Status.

- Mode 2, synchronous operation with path compensation

When this mode is first activated, the drive responds in a similar way as with the synchronous operation standard function (Mode 0).

- Mode 3, synchronous operation with synchronous specified value specification

Overview of synchronous operation modes

Operating Mode of P251	Kv P202	N Preset P207	Electron. Transmission	Reference to Leading Axis's Zero Pulse	Reference to Leading Axis's Absolute Position	Encoder Type
Speed synchronous operation	= 0	= 100%	i = 5	No	No	All
Relative angular synchronous operation	> 0	= 100%	i = 5	No	No	All

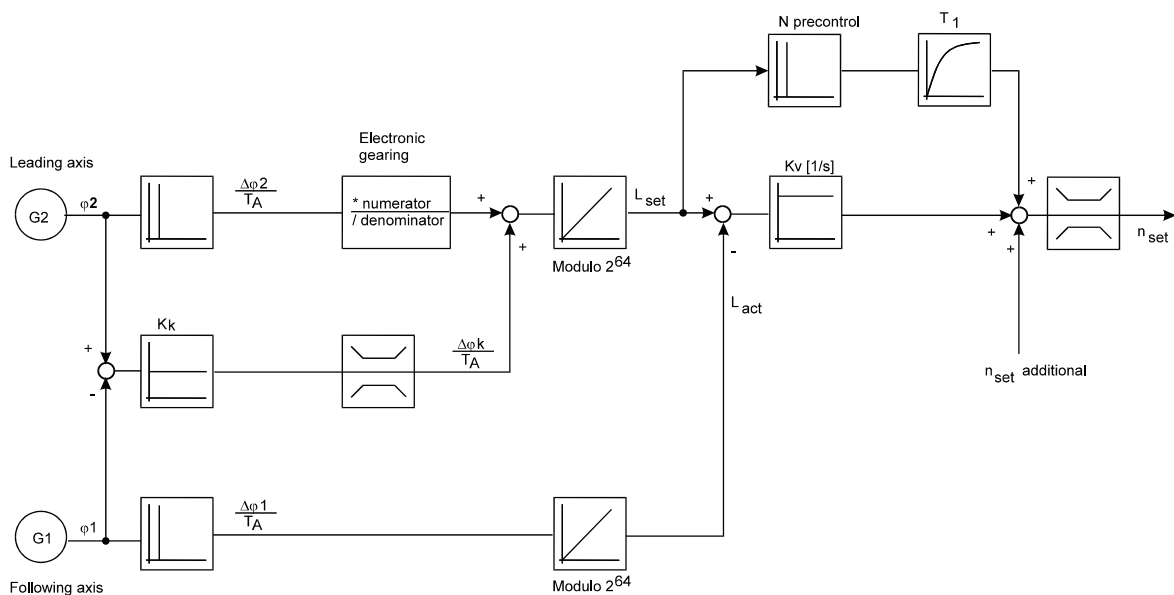

7.22 Analog Inputs

Function

The function module in combination with the 2 analog inputs enable the programming of 2 byte length parameters.

Six parameters are assigned to each input:

- *AI input channel:* input channel entry
- *AI smoothing:* smoothing time constant [ms].
- *AI scaling:* scaling factor entry
- *AI offset:* offset entry
- *AI threshold value:* sensitivity of inputs
- *AI target Pxxx:* target parameter number entry
- *AI value:* current output value.

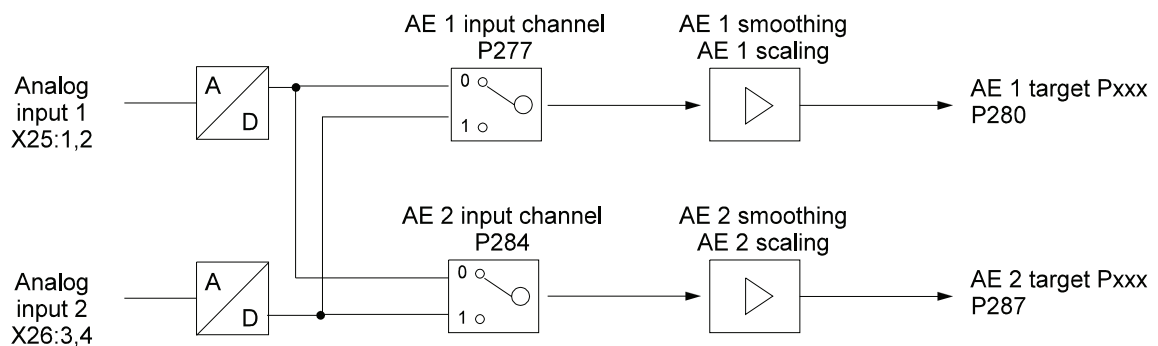

Parameter overview

Parameter	Name	Range min. ... max.	Unit	Display only
P277	AI 1 input channel	0 ... 1		
P278	AI 1 smoothing	1 ... 30	ms	
P279	AI 1 scaling	-2.00 ... 2.00		
P280	AI 1 target Pxxx	0 ... 700		
P281	AI 1 offset	-100.00 ... +100.00	%	
P282	AI 1 threshold value	0.00 ... 100.00	%	
P283	AI 1 value	-100.00 ... +100.00	%	×
P284	AI 2 input channel	0 ... 1		
P285	AI 2 smoothing	1 ... 30	ms	
P286	AI 2 scaling	-2.00 ... 2.00		
P287	AI 2 target Pxxx	0 ... 700		
P288	AI 2 offset	-100.00 ... +100.00	%	
P289	AI 2 threshold value	0.00 ... 100.00	%	
P290	AI 2 value	-100.00 ... +100.00	%	×



NOTE

The sequence of the parameter setting is irrelevant. Switching is carried out as soon as the target parameter number has been set.

The target parameter number must be reset to zero in order to deactivate an input. However, the target parameter still contains the last output value. If AI target Pxxx is deactivated or newly set, the parameter „AI x offset“ is additionally set to zero.

Cycle time of analog inputs: 1 ms

Parameter description

P 2 7 7 AI 1 input channel

P 2 8 4 AI 2 input channel

Entry of the analog input for respective channel.

The two hardware implemented analog inputs 1 and 2 can be connected with each input channels. It is further possible to connect an analog input with different input channels.

P 2 7 8 AI 1 smoothing

P 2 8 5 AI 2 smoothing

In order to smooth interference on the analog input signal a smoothing time constant can be entered in ms. Smoothing is switched off if the respective parameter is set to its minimum value.

P 2 7 9 AI 1 scaling

P 2 8 6 AI 2 scaling

These parameters enable scaling of the analog input variable.

The output values (see parameters P283, P290, P297, P304) of unsigned parameters are 0 till +100% and of signed parameters are -100 till +100%. Which analog input voltage this maximum values achieved depends on the scaling factor.

P280 AI 1 target Pxxx

P287 AI 2 target Pxxx

The receiver address for the output value can be set via this parameter.



NOTE

No target parameter number check is carried out.

P281 AI 1 offset

P288 AI 2 offset

These parameters can compensate for a possibly existing input voltage offset.

P282 AI 1 threshold value

P289 AI 2 threshold value

The sensitivity of the inputs can be set via the threshold values.

P283 AI 1 value

P290 AI 2 value

The AI value displays the respective current output value taking scaling and offset compensation into consideration.

Basics of equation:

Maximum target parameter value:

MAX_value

Analog input voltage:

$U_{in} \{ -10 \dots +10 \text{ V} \};$

$U_{inmax} = +10\text{V};$

Equation:

- Unsigned parameters:

$$AE_value[\%] = \frac{U_{in}[V] + 10V}{2 \cdot U_{inmax}[V]} * Scaling * 100\% + Offset$$

if AI-value > 100 % → AI-value = 100 %

- Signed parameters:

$$AE_value[\%] = \frac{U_{in}[V]}{U_{inmax}[V]} * Scaling * 100\% + Offset$$

if AI-value > 100 % → AI-value = 100 %

if AI-value < -100 % → AI-value = -100 %

Parameter

Both for signed and unsigned parameters

$|AI_value [\%]| < \text{threshold value} [\%]$ then $AI_value = 0 \%$

Written to the target parameter:

$$\text{Valuetarget} = \frac{AE_value[\%]}{100\%} \cdot \overline{\text{MAX_value}}$$

Examples:

Input voltage ↔ AI-value [%] * MAX_value
→ target parameter value

scaling = 1; offset = 0%; threshold value = 0%;

Unsigned target parameter:

10 V ↔ 100 % * MAX_value
5 V ↔ 75 % * MAX_value
0 V ↔ 50 % * MAX_value
- 5 V ↔ 25 % * MAX_value
- 10 V ↔ 0 % * MAX_value

Signed target parameter:

10 V ↔ 100 % * MAX_value
5 V ↔ 50 % * MAX_value
0 V ↔ 0 % * MAX_value
- 5 V ↔ -50 % * MAX_value
- 10 V ↔ -100 % * MAX_value

scaling = 2; offset = -100%; threshold value = 0%;

Unsigned target parameter:

10 V (100 % * MAX_value
5 V (50 % * MAX_value
0 V (0 % * MAX_value
- 5 V (0 % * MAX_value (limitation !)
- 10 V (0 % * MAX_value (limitation !)

Signed target parameter:

10 V (100 % * MAX_value
5 V (0 % * MAX_value
0 V (-100 % * MAX_value
- 5 V (-100 % * MAX_value (limitation !)
- 10 V (-100 % * MAX_value (limitation !)

scaling = 1; offset = 0; threshold value = 10.1%;

Unsigned target parameter:

10 V (100 % * MAX_value
5 V (75 % * MAX_value
0 V (50 % * MAX_value
-5 V (25 % * MAX_value
- 9 V (0 % * MAX_value (threshold !)
- 10 V (0 % * MAX_value

Signed target parameter:

10 V (100 % * MAX_value
5 V (50 % * MAX_value
1 V (0 % * MAX_value (threshold !)
- 1 V (0 % * MAX_value (threshold !)
- 5 V (-50 % * MAX_value
- 10 V (-100 % * MAX_value

Examples of characteristic curves:

Unsigned target parameter

Offset = 0 %; scaling = 1

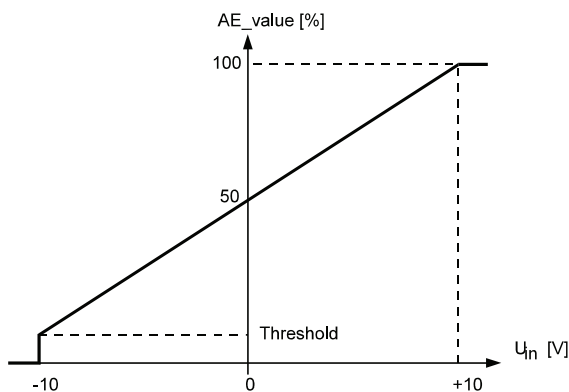

Signed target parameter

Offset = 0 %; scaling = 1

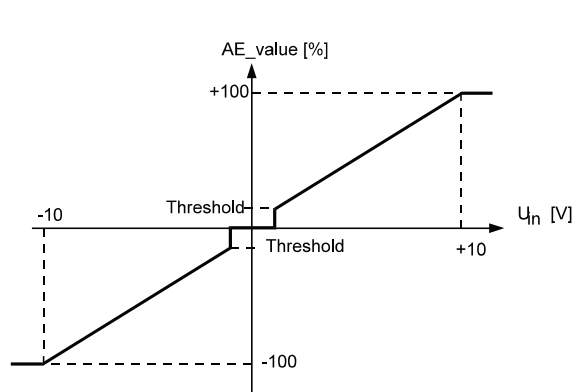

7.23 Analog Outputs

Function

The module „analog outputs“ transmits freely selectable (and scalable) parameter values to an analog output via a 12-bit digital-to-analog converter. It is possible transmitting 32-bit parameter either the low word to one channel or to channel 1 the low word and to channel 2 the high word of the 32 bit parameter. At a voltage range of ± 10 V the output current should not exceed 1 mA.

Parameter overview

Parameter	Name	Range min. ... max.	Unit	Display only
P338	AO state	0 ... FFFF	-	×
P337	AO test value	-10.000 ... +10.000	V	
P330	AO 1 source Pxxx	0 ... 700		
P331	AO 1 offset	-100000 ... +100000	Dig	
P332	AO 1 scaling	-25000 ... +25000	Dig/V	
P334	AO 2 source Pxxx	0 ... 700		
P335	AO 2 offset	-100000 ... +100000	Dig	
P336	AO 2 scaling	-25000 ... +25000	Dig/V	

Parameter description

P 3 3 8 AO state

Display of internal function module state.

Bit no.	Meaning
0	0: STOP, analog output 1 switched off 1: RUN, analog output 1 is active
1 ... 3	reserved
4	analog output 1 at negative threshold (-10V) (X26:7)
5	analog output 1 at positive threshold (+10V) (X26:7)
8	0: STOP, analog output 2 switched off 1: RUN, analog output 2 is active
9...11	reserved
12	analog output 2 at negative threshold (-10V) (X26:8)
13	analog output 2 at positive threshold (+10V) (X26:8)
14 ... 15	reserved

P 3 3 7 AO test value

The analog output (DA converter) can be tested via this parameter.

e.g.

AO 1 source Pxxx	P330 = 337
AO test value	P337 = +10
	→ analog output 1 = + 10 V
AO 1 scaling	P332 = -2000
	→ analog output 1 = - 5 V
AO offset channel 1	P331 = 14000
	→ analog output 1 = + 2 V

P 3 3 0 AO 1 source Pxxx

P 3 3 4 AO 2 source Pxxx

The output parameter numbers are entered here.

The respective channel is switched off, if this parameter is equal 0.

If a 32 bit parameter is programmed on one channel, the low word of this parameter is transmitted. To transmit the high word, both channels (P330 and P334) must be programmed to the same parameter. As a result channel 1 transmits the low word and channel 2 the high word of the 32 bit parameter. Is channel 1 programmed to another parameter then channel 2 transmits the low word. That means that the high word of a parameter can't be transmitted separately without the low word. Channel 1 transmits always the low word and channel 2 transmits always the high word.

P 3 3 1 AO 1 offset

P 3 3 5 AO 2 offset

The offset of the analog outputs is set here.

P 3 3 2 AO 1 scaling

P 3 3 6 AO 2 scaling

A scaling factor can also be selected for optimum parameter output. The respective channel is switched off, if this parameter is equal 0.

7.24 LED Display

Function

The module enables programming of the four available freely programmable LEDs of the LED display H22.

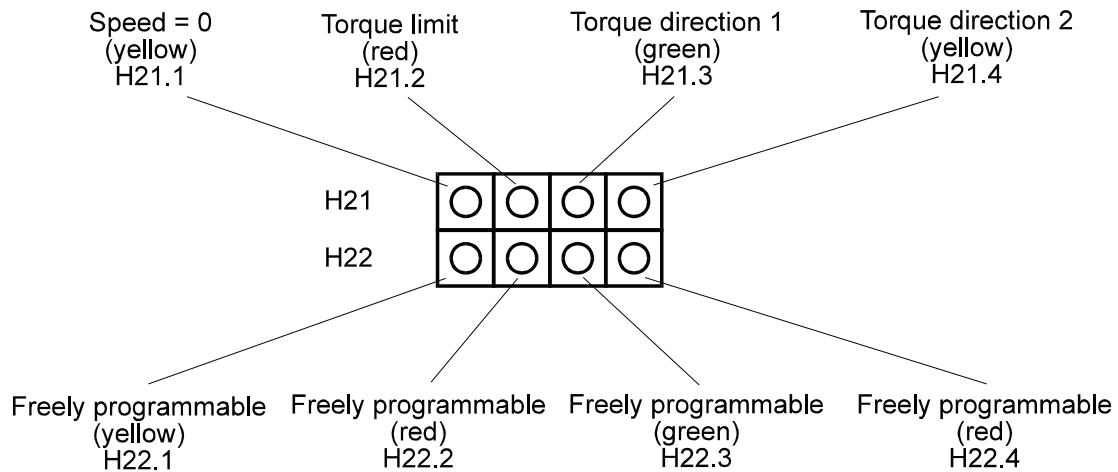

- *LED x source Pxxx:* Input of source parameter number.
- *LED x bit selection:* Selection of source parameter bits to which bit pattern must correspond.
- *LED x bit pattern:* If this bit pattern and the selected parameter bit pattern correspond to each other, the output is switched to high.

Note:

The sequence of the parameter setting is irrelevant. Switching takes place only after all three parameters have been set.

In order to deactivate an LED output, either the LED source Pxxx or the LED bit selection must be set to zero. The last switch state, however, remains stored in the output. The output can be programmed again by setting the relevant parameter again.

Example of programming procedure:

1. Enter source parameter number in *LED x source Pxxx* of your choice.
 - Has no effect on the LED output yet.
2. Enter *LED x bit pattern* of the above mentioned parameter.
 - Has no effect on the LED output yet.
3. Enter *bit selection*:
 - All bits which have not been selected are set to 0 in the LED bit pattern, the bits selected from the source parameter are compared to the LED bit pattern. If one of the two patterns corresponds to the source parameter pattern, the output is set to HIGH.

Parameter

Example:

1. First set *LED 1 source Pxxx* to 13,
LED 1 bit pattern to 0001,
and *LED 1 bit selection* to 0003.

→ if bit no. 1 and bit no. 2 of parameter 13 result in „1“, the LED H22.1 is switched to high.

2. Then set *LED 2 source Pxxx* to 13,
LED 2 bit pattern to 0003,
and *LED 2 bit selection* to 0003.

→ If bit no. 1 and bit no. 2 of parameter 13 result in „3“, the LED H22.2 is set to high.

Parameter overview

Parameter	Name	Range min. ... max.	Unit	Display only
P362	LED state	0000 ... FFFF		×
P350	LED 1 source Pxxx	0 ... 700		
P351	LED 1 bit selection	0000 ... FFFF		
P352	LED 1 bit pattern	0000 ... FFFF		
P353	LED 2 source Pxxx	0 ... 700		
P354	LED 2 bit selection	0000 ... FFFF		
P355	LED 2 bit pattern	0000 ... FFFF		
P356	LED 3 source Pxxx	0 ... 700		
P357	LED 3 bit selection	0000 ... FFFF		
P358	LED 3 bit pattern	0000 ... FFFF		
P359	LED 4 source Pxxx	0 ... 700		
P360	LED 4 bit selection	0000 ... FFFF		
P361	LED 4 bit pattern	0000 ... FFFF		

Parameter description

P 362 LED state

This parameter display the state of the function module. .

Bit no.	Meaning
0	1: LED 1 completely programmed
1	1: LED 2 completely programmed
2	1: LED 3 completely programmed
3	1: LED 4 completely programmed
4 ... 7	reserved
8	actual state of LED H22.1
9	actual state of LED H22.2
10	actual state of LED H22.3
11	actual state of LED H22.4
12 ... 15	reserved

P 350 LED 1 source Pxxx**P 353** LED 2 source Pxxx**P 356** LED 3 source Pxxx**P 359** LED 4 source Pxxx

The parameter number of the source parameter for LED display is entered.

P 351 LED 1 bit selection**P 354** LED 2 bit selection**P 357** LED 3 bit selection**P 360** LED 4 bit selection

The bits to be compared are selected in the source parameter.

P 352 LED 1 bit pattern**P 355** LED 2 bit pattern**P 358** LED 3 bit pattern**P 361** LED 4 bit pattern

Bit pattern which is compared to the source parameter pit pattern.

7.25 Digital Inputs

The module and the four available digital inputs enable parameter programming.

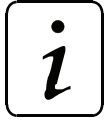

NOTE

The controller can reach the state „operation enabled“ immediately after the switch on of the electronic power supply, if the control word (see function module drive manager) is manipulated by digital inputs (see function module digital inputs) and the hardware enable is active.

During the programming of digital inputs this option must be considered and protective measures have to be ensured on machine-side.

Four parameters are assigned to each input:

- *DI x target Pxxx*: Input of target parameter number
- *DI x bit selection*: Selection of the target parameter bits which are to be altered.
- *DI x LOW pattern*: Bit pattern which is written into the target parameter if switch is OFF.
- *DI x HIGH pattern*: Bit pattern which is written into the target parameter if switch is ON.

The inputs only evaluate the transitions

Hence it is possible to manipulate the same parameter via several inputs.

Example: Two inputs act on the same parameter bit

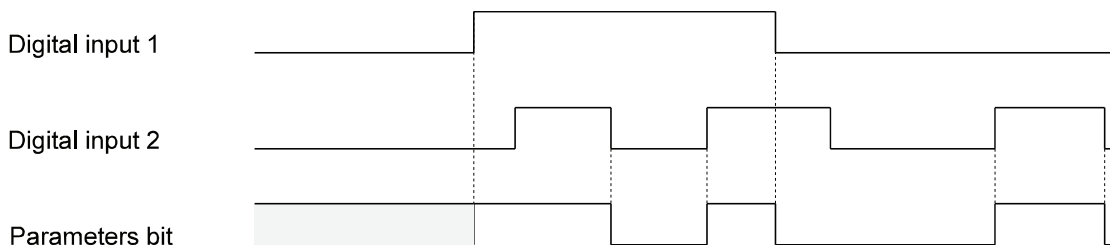

The four inputs are sampled every 4 ms at an interval of approx. 20 µs. In the event of simultaneous status change of two signals the signal with the higher weight is taken over (digital input 1 has the lowest weight, digital input 4 the highest).

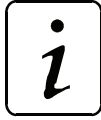

NOTE

The activation of a digital input results in setting all parameters of the selected input.

Following order must be observed:

1. DO x target Pxxx
2. DO x bit selection
3. DO x LOW pattern
4. DO x HIGH pattern

In order to deactivate an input the DI target Pxxx must be set to 0.

Example of programming procedure:

1. Enter target parameter number in *DI x target Pxxx* of desired input.
⇒ Has no effect on the target parameter yet.
2. Enter *DI x LOW-* and *HIGH pattern* of the above mentioned input.
⇒ Has no effect on the target parameter yet.
3. Enter *DI x bit selection*:
⇒ all bits which have not been selected are set to 0 in the LOW and HIGH patterns;
the selected bits are set to 0 in the target parameter and are replaced by the corresponding bit pattern (according to switch position).

Examples:

1. Input 1 should set parameter P013 to 0 (switch is LOW) and to 1 (switch is HIGH).

Set

<i>DI 1 target Pxxx</i> (P370) to	13,
<i>DI 1 LOW pattern</i> (P372) to	0000,
<i>DI 1 HIGH pattern</i> (P373) to	0001,
<i>DI 1 bit selection</i> (P371) to	FFFF.

2. Through programming of a further input the values 2 and 3 should adjusted in parameter P013. Following sequence is necessary:

Set

DI 1 target Pxxx (P370) to 13,
DI 1 LOW pattern (P372) to 0000,
DI 1 HIGH pattern (P373) to 0001,
DI 1 bit selection (P371) to FFFD
DI 2 target Pxxx (P374) to 13,
DI 2 LOW pattern (P376) to 0000,
DI 2 HIGH pattern (P377) to 0002,
DI 2 bit selection (P375) to FFFE.

→ The digital input 1 effects bit no. 0 and. 2 till 15;
the digital input 2 effects bit no. 1 till 15.

Bit no.	15	14	13	12	11	10	9	8	7	6	5	4	3	2	1	0
Example for start value P013	1	1	1	1	0	0	0	0	1	1	1	1	0	1	0	1
input 1 → HIGH	0	0	0	0	0	0	0	0	0	0	0	0	0	0	0	1
input 2 → HIGH	0	0	0	0	0	0	0	0	0	0	0	0	0	0	1	1
input 1 → LOW	0	0	0	0	0	0	0	0	0	0	0	0	0	0	1	0
input 2 → LOW	0	0	0	0	0	0	0	0	0	0	0	0	0	0	0	0

3. The digital input 3 should effect bit no. 4 and 11 of parameter P120.

Set

DI 3 target Pxxx (P378) to 120,
DI 3 LOW pattern (P380) to 0800,
DI 3 HIGH pattern (P381) to 0010,
DI 3 bit selection (P379) to 0810

Bit no.	15	14	13	12	11	10	9	8	7	6	5	4	3	2	1	0
Start value P120	0	0	0	0	0	0	0	0	0	0	0	0	1	1	1	1
input 2 → HIGH	0	0	0	0	0	0	0	0	0	0	0	1	1	1	1	1
input 2 → LOW	0	0	0	0	1	0	0	0	0	0	0	0	1	1	1	1

Parameter overview

parameter	Name	Range min. ... max.	Unit	Display only
P382	DI state	0000 ... FFFF		×
P370	DI 1 target Pxxx	0 ... 700		
P371	DI 1 bit selection	0000 ... FFFF		
P372	DI 1 LOW pattern	0000 ... FFFF		
P373	DI 1 HIGH pattern	0000 ... FFFF		
P374	DI 2 target Pxxx	0 ... 700		
P375	DI 2 bit selection	0000 ... FFFF		
P376	DI 2 LOW pattern	0000 ... FFFF		
P377	DI 2 HIGH pattern	0000 ... FFFF		
P378	DI 3 target Pxxx	0 ... 700		
P379	DI 3 bit selection	0000 ... FFFF		
P380	DI 3 LOW pattern	0000 ... FFFF		
P381	DI 3 HIGH pattern	0000 ... FFFF		
P342	DI 4 target Pxxx	0 ... 700		
P343	DI 4 bit selection	0000 ... FFFF		
P344	DI 4 LOW pattern	0000 ... FFFF		
P345	DI 4 HIGH pattern	0000 ... FFFF		

Parameter description

P 382 DI state

This parameter indicates the state of input programming.

Bit no.	Meaning
0	1: input 1 completely programmed
1	1: input 2 completely programmed
2	1: input 3 completely programmed
3	1: input 4 completely programmed
4 ... 7	reserved
8	actual state input 1 (X26:15)
9	actual state input 2 (X26:16)
10	actual state input 3 (X26:17)
11	actual state input 4 (X26:18)
12 ... 13	reserved
14	actual state rapid halt input (X26:19)
15	actual state pulse / controller enabling (X26:14)

P 370 DI 1 target Pxxx

P 374 DI 2 target Pxxx

P 378 DI 3 target Pxxx

P 342 DI 4 target Pxxx

This parameter indicates the parameter number of the target parameter for input 1 till 4.

P 371 DI 1 bit selection

P 375 DI 2 bit selection

P 379 DI 3 bit selection

P 343 DI 4 bit selection

The bits to be altered are selected in the target parameter.

P 372 DI 1 LOW pattern

P 376 DI 2 LOW pattern

P 380 DI 3 LOW pattern

P 344 DI 4 LOW pattern

Bit pattern which is written into the selected target parameter bits when digital input is LOW.

P 373 DI 1 HIGH pattern

P 377 DI 2 HIGH pattern

P 381 DI 3 HIGH pattern

P 345 DI 4 HIGH pattern

Bit pattern which is written into the selected target parameter bits when digital input is HIGH.

7.26 Digital Outputs

Function

The module enables programming of the three available digital outputs. Three parameters are assigned to each output:

- DI output ID no.: Input of source parameter number
(only 2-byte parameters admissible)
- DI bit selection: Selection of source parameter bits to which bit pattern must
correspond.
- DI bit pattern If this bit pattern and the selected parameter bit pattern correspond to
each other, the output is switched to HIGH.

Note:

The sequence of the parameter setting is irrelevant. Switching takes place only after all three parameters have been set.

In order to deactivate an output either DI source Pxxx or DI bit selection must be set to 0. The last switch state, however, remains stored in the output. The output can be programmed again by setting the relevant parameter again.

Example of programming procedure:

1. Enter source parameter number in *DO x source Pxxx* of your choice.
 - Has no effect on the output yet.
2. Enter *DO x bit pattern* of the above mentioned parameter.
 - Has no effect on the output yet.
3. Enter *bit selection*:
 - All bits which have not been selected are set to 0 in the DO bit pattern, the bits selected from the source parameter are compared to the DO bit pattern.
If one of the two patterns corresponds to the source parameter pattern, the output is set to HIGH.

Example:

1. First set *DO 1 source Pxxx* to 13,
DO 1 bit pattern to 0001,
and *DO 1 bit selection* to 0003.
 - If bit no. 1 and bit no. 2 of parameter P013 result in „1“, the output 1 is switched to high.
2. Then set *DO 2 source Pxxx* to 13,
DO 2 bit pattern to 0003,
and *DO 2 bit selection* to 0003.
 - If bit no. 1 and bit no. 2 of parameter 13 result in „3“, the output 2 is set to high.

Parameter overview

Parameter	Name	Range min. ... max.	Unit	Display only
P383	DO 1 source Pxxx	0 ... 700		
P384	DO 1 bit selection	0000 ... FFFF		
P385	DO 1 bit pattern	0000 ... FFFF		
P386	DO 2 source Pxxx	0 ... 700		
P387	DO 2 bit selection	0000 ... FFFF		
P388	DO 2 bit pattern	0000 ... FFFF		
P389	DO 3 source Pxxx	0 ... 700		
P390	DO 3 bit selection	0000 ... FFFF		
P391	DO 3 bit pattern	0000 ... FFFF		
P392	DO state	0000 ... FFFF		×

Parameter description

P 383 DO 1 source Pxxx

P 386 DO 2 source Pxxx

P 389 DO 3 source Pxxx

This parameter indicates the parameter number of the source parameter for outputs 1, 2 or 3.

P 384 DO 1 bit selection

P 387 DO 2 bit selection

P 390 DO 3 bit selection

The bits to be compared are selected in the source parameter.

P 385 DO 1 bit pattern

P 388 DO 2 bit pattern

P 391 DO 3 bit pattern

Bit pattern which is compared to the source parameter bit pattern.

P 392 DO state

This parameter shows the state of the function module..

Bit no.	Meaning
0	1: output 1 completely programmed
1	1: output 2 completely programmed
2	1: output 3 completely programmed
3 ... 7	reserved
8	actual state output 1 (X26:21)
9	actual state output 2 (X26:22)
10	actual state output 3 (X26:23)
11 ... 15	reserved

7.27 External Digital input

This function module in combination with the additional board MFM-01 enables the manipulation of 16 bit parameters (programming see Digital Inputs).

Parameter overview

Parameter	Name	Range min. ... max.	Unit	Display only
P500	XDI state	0000 ... FFFF		×
P501	XDI 1 target Pxxx	0 ... 700		
P502	XDI 1 bit selection	0000 ... FFFF		
P503	XDI 1 LOW pattern	0000 ... FFFF		
P504	XDI 1 HIGH pattern	0000 ... FFFF		
P505	XDI 2 target Pxxx	0 ... 700		
P506	XDI 2 bit selection	0000 ... FFFF		
P507	XDI 2 LOW pattern	0000 ... FFFF		
P508	XDI 2 HIGH pattern	0000 ... FFFF		
P509	XDI 3 target Pxxx	0 ... 700		
P510	XDI 3 bit selection	0000 ... FFFF		
P511	XDI 3 LOW pattern	0000 ... FFFF		
P512	XDI 3 HIGH pattern	0000 ... FFFF		
P513	XDI 4 target Pxxx	0 ... 700		
P514	XDI 4 bit selection	0000 ... FFFF		
P515	XDI 4 LOW pattern	0000 ... FFFF		
P516	XDI 4 HIGH pattern	0000 ... FFFF		
P517	XDI 5 target Pxxx	0 ... 700		
P518	XDI 5 bit selection	0000 ... FFFF		
P519	XDI 5 LOW pattern	0000 ... FFFF		
P520	XDI 5 HIGH pattern	0000 ... FFFF		
P521	XDI 6 target Pxxx	0 ... 700		
P522	XDI 6 bit selection	0000 ... FFFF		
P523	XDI 6 LOW pattern	0000 ... FFFF		
P524	XDI 6 HIGH pattern	0000 ... FFFF		
P525	XDI 7 target Pxxx	0 ... 700		
P526	XDI 7 bit selection	0000 ... FFFF		
P527	XDI 7 LOW pattern	0000 ... FFFF		
P528	XDI 7 HIGH pattern	0000 ... FFFF		
P529	XDI 8 target Pxxx	0 ... 700		
P530	XDI 8 bit selection	0000 ... FFFF		
P531	XDI 8 LOW pattern	0000 ... FFFF		
P532	XDI 8 HIGH pattern	0000 ... FFFF		

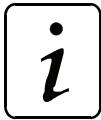

NOTE

The controller can reach the state „operation enabled“ immediately after the switch on of the electronic power supply, if the control word (see function module drive manager) is manipulated by digital input (see function module digital input) and the hardware enable is active.

During the programming of digital input this option must be considered and protective measures have to be ensured on machine-side.

Parameter description

P 5 0 0 XDI state

This parameter indicates the state of input programming.

Bit no.	Meaning
0	1: input 1 completely programmed
1	1: input 2 completely programmed
2	1: input 3 completely programmed
3	1: input 4 completely programmed
4	1: input 5 completely programmed
5	1: input 6 completely programmed
6	1: input 7 completely programmed
7	1: input 8 completely programmed
8	actual state input 1
9	actual state input 2
10	actual state input 3
11	actual state input 4
12	actual state input 5
13	actual state input 6
14	actual state input 7
15	actual state input 8

P 5 0 1 XDI 1 target Pxxx

P 5 0 5 XDI 2 target Pxxx

P 5 0 9 XDI 3 target Pxxx

P 5 1 3 XDI 4 target Pxxx

P 5 1 7 XDI 5 target Pxxx

P 5 2 1 XDI 6 target Pxxx

P 5 2 5 XDI 7 target Pxxx

P 5 2 9 XDI 8 target Pxxx

This parameter indicates the parameter number of the target parameter for input 1 till 8.

P 5 0 2 XDI 1 bit selection

P 5 0 6 XDI 2 bit selection

P 5 1 0 XDI 3 bit selection

P 5 1 4 XDI 4 bit selection

P 5 1 8 XDI 5 bit selection

P 5 2 2 XDI 6 bit selection

P 5 2 6 XDI 7 bit selection

P 5 3 0 XDI 8 bit selection

The bits to be altered are selected in the target parameter.

P 5 0 3 XDI 1 LOW pattern

P 5 0 7 XDI 2 LOW pattern

P 5 1 1 XDI 3 LOW pattern

P 5 1 5 XDI 4 LOW pattern

P 5 1 9 XDI 5 LOW pattern

P 5 2 3 XDI 6 LOW pattern

P 5 2 7 XDI 7 LOW pattern

P 5 3 1 XDI 8 LOW pattern

Bit pattern which is written into the selected target parameter bits when digital input is LOW.

P 5 0 4 XDI 1 HIGH pattern

P 5 0 8 XDI 2 HIGH pattern

P 5 1 2 XDI 3 HIGH pattern

P 5 1 6 XDI 4 HIGH pattern

P 5 2 0 XDI 5 HIGH pattern

P 5 2 4 XDI 6 HIGH pattern

P 5 2 8 XDI 7 HIGH pattern

P 5 3 2 XDI 8 HIGH pattern

Bit pattern which is written into the selected target parameter bits when digital input is HIGH.

7.28 External Digital Outputs

This function module in combination with the additional board MFM-01 enables the output of 16 bit parameters (programming see Digital Outputs).

Parameter overview

Parameter	Name	Range min. ... max.	Unit	Display only
P533	XDO state	0000 ... FFFF		×
P534	XDO mode	000 ... 00FF		
P535	XDO 1 source Pxxx	0 ... 700		
P536	XDO 1 bit selection	0000 ... FFFF		
P537	XDO 1 bit pattern	0000 ... FFFF		
P538	XDO 2 source Pxxx	0 ... 700		
P539	XDO 2 bit selection	0000 ... FFFF		
P540	XDO 2 bit pattern	0000 ... FFFF		
P541	XDO 3 source Pxxx	0 ... 700		
P542	XDO 3 bit selection	0000 ... FFFF		
P543	XDO 3 bit pattern	0000 ... FFFF		
P544	XDO 4 source Pxxx	0 ... 700		
P545	XDO 4 bit selection	0000 ... FFFF		
P546	XDO 4 bit pattern	0000 ... FFFF		
P547	XDO 5 source Pxxx	0 ... 700		
P548	XDO 5 bit selection	0000 ... FFFF		
P549	XDO 5 bit pattern	0000 ... FFFF		
P550	XDO 6 source Pxxx	0 ... 700		
P551	XDO 6 bit selection	0000 ... FFFF		
P552	XDO 6 bit pattern	0000 ... FFFF		
P553	XDO 7 source Pxxx	0 ... 700		
P554	XDO 7 bit selection	0000 ... FFFF		
P555	XDO 7 bit pattern	0000 ... FFFF		
P556	XDO 8 source Pxxx	0 ... 700		
P557	XDO 8 bit selection	0000 ... FFFF		
P558	XDO 8 bit pattern	0000 ... FFFF		

Parameter

Parameter description

P 5 3 3 XDO state

This parameter displays the state of output programming and outputs..

Bit no.	Meaning
0	1: output 1 completely programmed
1	1: output 2 completely programmed
2	1: output 3 completely programmed
3	1: output 4 completely programmed
4	1: output 5 completely programmed
5	1: output 6 completely programmed
6	1: output 7 completely programmed
7	1: output 8 completely programmed
8	actual state of output 1
9	actual state of output 2
10	actual state of output 3
11	actual state of output 4
12	actual state of output 5
13	actual state of output 6
14	actual state of output 7
15	actual state of output 8

P 5 3 5 XDO 1 source Pxxx

P 5 3 8 XDO 2 source Pxxx

P 5 4 1 XDO 3 source Pxxx

P 5 4 4 XDO 4 source Pxxx

P 5 4 7 XDO 5 source Pxxx

P 5 5 0 XDO 6 source Pxxx

P 5 5 3 XDO 7 source Pxxx

P 5 5 6 XDO 8 source Pxxx

This parameter indicates the parameter number of the source parameter for outputs 1 till 8.

P 5 3 6 XDO 1 bit selection

P 5 3 9 XDO 2 bit selection

P 5 4 2 XDO 3 bit selection

P 5 4 5 XDO 4 bit selection

P 5 4 8 XDO 5 bit selection

P 5 5 1 XDO 6 bit selection

P 5 5 4 XDO 7 bit selection

P 5 5 7 XDO 8 bit selection

The bits to be compared are selected in the source parameter.

P 5 3 7 XDO 1 bit pattern

P 5 4 0 XDO 2 bit pattern

P 5 4 3 XDO 3 bit pattern

P 5 4 6 XDO 4 bit pattern

P 5 4 9 XDO 5 bit pattern

P 5 5 2 XDO 6 bit pattern

P 5 5 5 XDO 7 bit pattern

P 5 5 8 XDO 8 bit pattern

Bit pattern which is compared to the source parameter bit pattern.

7.29 Service Interface

Function

The service interface allows communication with the PC operating program. The BASS protocol is operated via the RS 232 interface.

The address of each drive is set in binary code at the controller front via DIP switch S 20. Bit no. 0 thus corresponds to switch 1, bit no. 1 to switch 2 etc.

The RS 232 interface is constructed potential-free, the operating mode is full-duplex.

Data format: 8 data bits, 1 stop bit, no parity

Transmission speed: 9600 baud

Transmission format: ASCII

Communication PC ⇒ drive

BOF	ADDRESS	CONTROL	PARAMETER NO.	DATA	CHECKS.	EOF
-----	---------	---------	---------------	------	---------	-----

Example 1: Set P002 to 75 %

#	0	0	0	0	3	E	0	0	0	2	1	D	4	C	E	8	0D	0A
						Write operating data (one element, first transmission)	P002				1D4C = 7500 = 75 %							

Example 2: Read P051

#	0	0	0	0	3	C	0	0	3	3	F	D	0D	0A
						Read operating data (one element, first transmission)	P051							

BOF # (23_{hex})
Address of the drive 0_{dec} to 255_{dec} (00_{hex} to FF_{hex})

Control

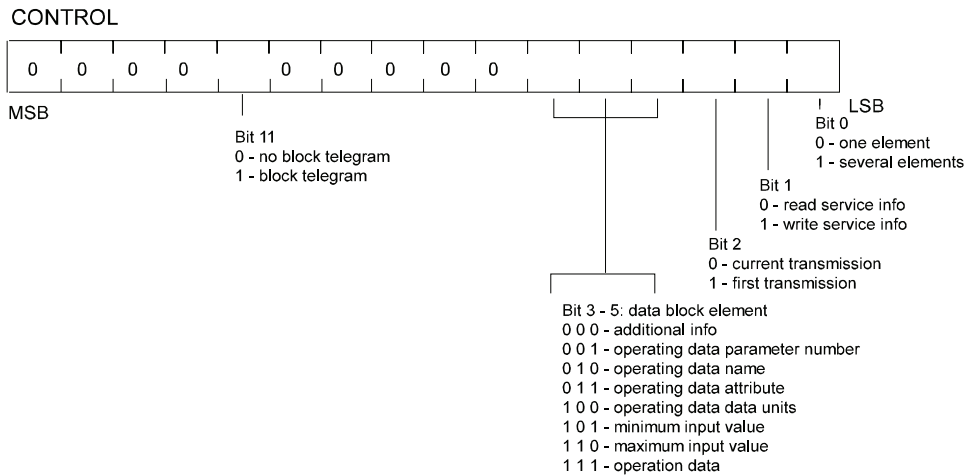

Parameter number Hexadecimal value of the parameter number as an ASCII character

Data

Element, error type

- Number are given as hexadecimal numbers and are transmitted as ASCII characters
- The half-byte with the highest value is transmitted first
- Really text begins with two words following one after another which contains the length of the text:

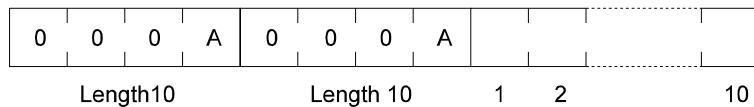

Data

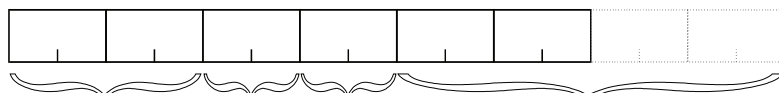

32 bit ASCII
no. of transmitted
block



This number
is displayed on
the 14 lower bits
of P173.

16 bit HEX
number of all trans-
mitted
blocks



This value
is trans-
mitted to
the DPRAM
address
09E h
(number of
all blocks).

16 bit HEX
size of the
transmitted
block



This value
is trans-
mitted to
the DPRAM
address
09C h
(actual size
of block).

HEX
data



This data is transmitted to
the DPRAM and written
from address 0A0 h.

Checksum Sum of the hexadecimal values of all ASCII characters without BOF and EOF. Any overflow is also added (234_{hex}→36_{hex})

EOF <CR> <LF> (0D_{hex}, 0A_{hex})

Parameter

Communication drive ⇒ PC

Before the drive answered the echo telegram is sent from drive to pc!

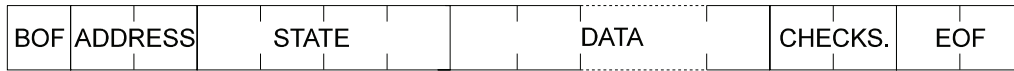

Example 1: Set P002 to 75 %

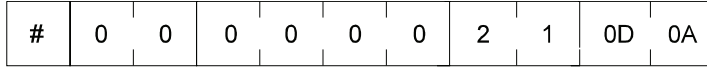

No error

Example 2: Read P051

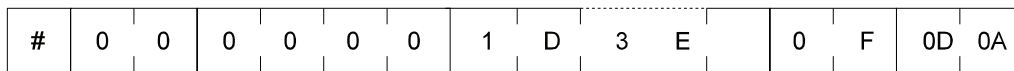

No error

1D3E =
7486 = 74.86 % N actual value

- BOF** # (23_{hex})
- Address of the drive** 0_{dec} to 255_{dec} (00_{hex} to FF_{hex})
- State**

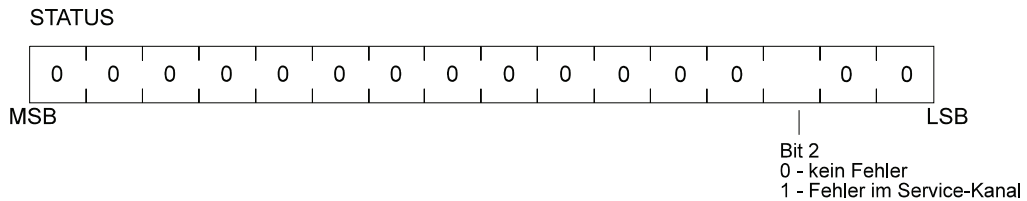

- Parameter number** Hexadecimal value of the parameter number as an ASCII character
- Data** Element, data state, error type
Really text begins with two words following one after another which contains the length of the text:

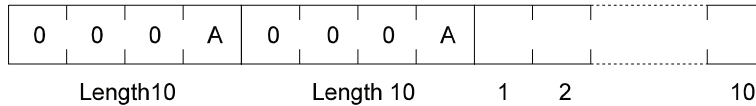

- Checksum** Sum of the hexadecimal values of all ASCII characters without BOF and EOF. Any overflow is also added (234_{hex}→36_{hex})
- EOF** <CR> <LF> (0D_{hex}, 0A_{hex})

Error table

Error number	Meaning
0	No fault
1	Element is not available
2	Datum is too short
3	Datum is too long
4	Datum is not alterable
5	Parameter is write protected
6	Datum is smaller than minimum value
7	Datum is greater than maximum value
8	Datum is invalid
9	Obtaining of parameter is invalid

Parameter overview

Parameter	Name	Range min. ... max.	Unit	Display only
P170	SI state	0000 ... FFFF		×
P171	SI baud rate	50 ... 19200	Baud	×
P172	SI mode	0000 ... 0003		
P173	SI array state	0000 ... FFFF		×

Parameter description

P170 SI state

Write-access to the drive parameters is managed via parameter M communication source (P126) in the drive manager. The drive parameter can only be altered via the service interface when bit no. 0 of this parameter is set to 1. If the bit is set to 0 write-access is inhibited and only read-access to the parameter values granted.

See also M communication source (P126)

Bit no.	Meaning
0 ... 3	status of function module 0001: RUN (all parameters can be read and write) 0000: STOP (all parameters can be read)
4 ... 11	drive address 0 ... 255 (representation of the DIP switch S20)
12 ... 15	reserved

Parameter

P 171 SI baud rate

The service baud rate can only be displayed and is set to a fixed value of 9600 baud.

P 172 SI mode

Bit no.	Meaning
0	1: Standard setting All set and actual values are standardized in % 0: All set and actual values are transferred in internal standardization
1	1: Standard setting 0: Service mode
2 ... 15	reserved

P 173 SI array state

Bit no.	Meaning
0 ... 3	Number of actual transferred block
4	Data in RAM puffer valid
5	Block is just written to RAM puffer

7.30 Link to USS® Protocol



NOTE

The USS® protocol is a registered trade mark of Fa. Siemens AG.

Function

The link to USS® protocol allows the user to carry out communication between master and slave with a fixed message length.

Data transmission and data save description

(Layer 1 and 2 in the ISO/OSI layer model)

The following arrangement applies to data transmission and data save:

1. The operating mode is strictly half-duplex.
2. It is a bus-capable master-slave protocol, where the non-system computer is the master. The drives are always the slaves.
3. Message length is fixed and cannot be altered on-line.
4. All messages must be transmitted completely, i.e. with no gaps in them. No acknowledgement or repeat messages are needed due to the cyclic message exchange.
5. The transmission framework for the individual characters is defined as follows:
 1 start bit, 8 data bits, 1 parity bit (even parity), 1 stop bit.
 The start character of each message (master and slave messages) is the ASCII character STX = 02hex in conjunction with a preceding transmission pause of 33 bits. All other characters in the message are not code-dependent.
 A Hamming distance of $d = 4$ is attained via various data saving methods. This means that at least 4 bit errors per message must occur at defined places in the message before a faulty message is no longer recognised as such.

Message structure

	1 byte	1 byte	1 byte	n byte	1 byte
STX	LGE	ADR	net data block with n character	BCC	

STX:Start of Text (02hex)

LGE:Message length 2 - 254 bytes (without STX and LGE, but with ADR and BCC)

ADR:Slave address 0 - 31; 32: broadcast message, = 64: mirror message

BCC:Block Check Character (EXOR linking of all characters)

Transmission procedure

The start character STX (02hex) is not itself enough to mark the start of a message, as this bit combination can also appear in the middle of the message e.g. in the net data block. Thus a transmission pause of 33 bits is stipulated for the master and slave messages. A valid start to a message is only marked when a received STX is preceded by a transmission pause. As a result of the semi-duplex operation (i.e. only transmission or reception at any one time), this start pause is guaranteed when in error-free operation.

The definition of the start pause requires that the pause time never comes between two characters within a message. For this reason, all messages are to be transmitted without gaps.

The drives only respond when they have received a complete and error-free message, sent to their address.

If a slave does not send a reply to a master message, this can result from the following:

- Slave is not yet switched on
- Slave has received a faulty message
- Communication cable is open-circuit or faulty
- Parameter M communication source (P126) bit no. 2 is not set to 1 (USS[®] protocol)

Normally, the slave sends a reply message for each master message after processing it briefly. Where there are more slaves in use, the procedure is shown in the following diagram:

2-wire and 4-wire modes (half duplex)

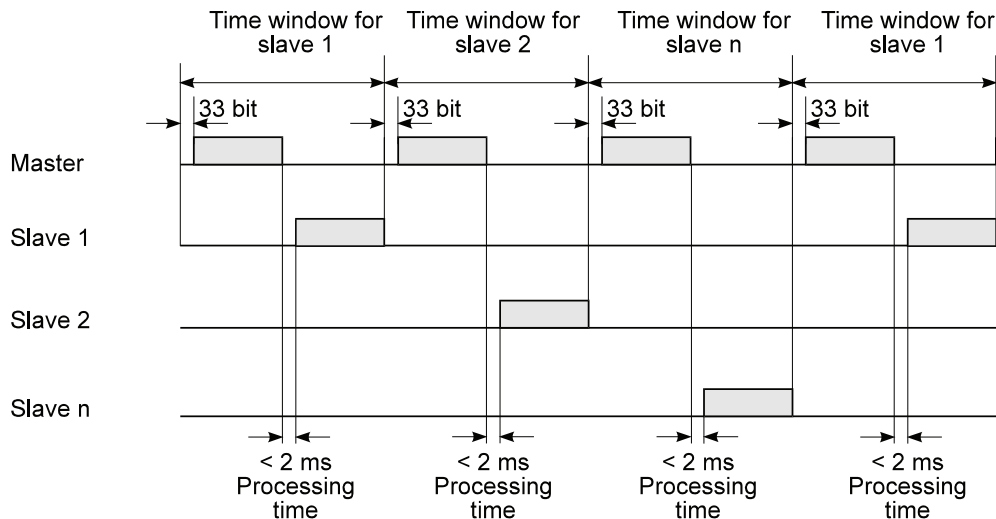

Structure of the net data block

The net data block is divided into two ranges:

- PIV (Parameter Identification Value) range
 - PD (Process Data) range
- Parameter exchange between the two communication partners, i.e. reading and writing of parameter values and reading of the parameter description is carried out via the PIV range.
 - The PD range contains necessary signals for automation:
control word and specified values from master to slave
status word and actual values from slave to master

Both ranges comprise the net data block. This structure applies to the job message (Master → Slave) as well as the reply message (Slave → Master))

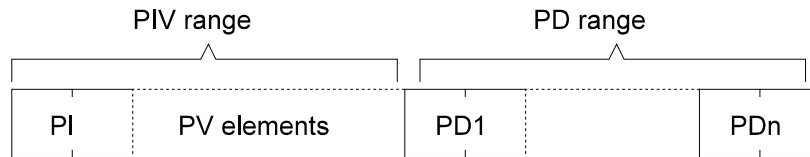

- PI:** The parameter identifier (PI) serves to identify and issue jobs and replies for parameter processing, and always has word length (= 16 bits)
- PV element:** Parameter value, if necessary with additional or other user data. If only PD data is to be transmitted in the net data block, the number of PV elements can be 0.
- PD1-PDn:** Process data (control/status word and specified/actual values)
 The necessary specified and actual values are transmitted in this range. The length of this range must be agreed between the drive and the control. If only PIV data is to be transmitted in the net data block, the number of PD elements can be 0.
 Depending on the transmission direction, either the control word or the status word is to be transmitted in the PD1. The specified/actual values are transmitted in the following process data PD2 to PDn.

Bus addresses

The bus addresses are set, binary-coded, at the front of the controller with the help of DIP switch. DIP no. 1 thus corresponds to bit no. 0 of the bus address, DIP no. 2 to bit no. 1 etc.

Mirror message

The bus master can request a mirror message from the slave. The master transmits a message to the appropriate slave which only differs from a normal message in that bit no. 7 is set in the address byte ADR.

The slave transmits this message immediately after reception as a reply message to the master. The mirror message allows the transmission function between master and slave to be tested. This is useful e.g. for step-by-step commissioning or fault-finding in the bus system.

Broadcast message

A broadcast message is a master message transmitted simultaneously to all slaves, which only differs from a normal message in that bit no. 32 is set in the address byte ADR (bit no. 5 = 1).

Broadcast messages are not answered by the slaves. However, in this case the master does not expect a reply message.

Net data processing takes place as follows:

- Specified values in the PD range are not accepted
- Jobs in the PIV range are not processed
- The control word in PD1 is linked to its screen in PV1, so that only those bits in the drive control word are updated which are set to „1“ in the screen. The bits set to „0“ are not updated, their old status is retained.

Broadcast mode is only possible when the PIV number is set to > 3 and the PD number to > 1. In addition, the job identifier must be set to 0 „no job“.

If PIV number set equal 0 the control word are accepted without screen.

Structure of the PIV range

The structure of the PIV range is always the same in the sequence of its elements and only differs in its standard form by the number of its parameter values (PV).

The PIV range can be set to a specific length (3 or 4 words long) via parameter USS® PIV number (P183).

If no PIV range is to be available in the net data block, the PIV number must be set to 0, then parameters can be assigned via this interface.

- PIV range with set message length

Standard form with parameter values as word size
(PIV number = 3)

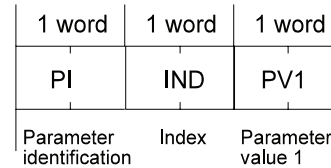

Standard form with parameter values as double word size
(PIV number = 4)

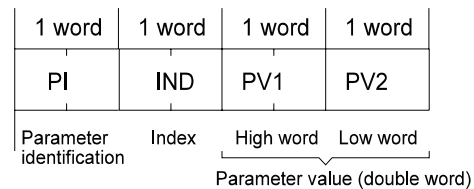

-applies to both job and reply messages.

- Description of the individual PIV elements

- Parameter identification (PI)

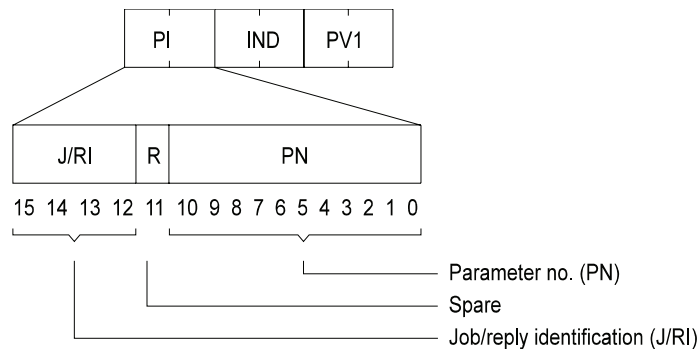

- Job and reply identification

The jobs which are sent from the master to the slave are coded in the job identification. The slave processes the job and formulates the relevant reply, which is coded (J/RI) and sent to the master. The J/RI specifies that jobs or replies are clearly defined via the PI (J/RI + PN) and, in the case of certain jobs/replies, additionally via the index word.

Job identification (master → slave)

Bit no. 15 14 13 12				Function	Description
0	0	0	0	no job	no job for the PIV interface
0	0	0	1	request PV	requests a PV
0	0	1	0	change PV (word)	writes a PV word (16 bit)
0	0	1	1	change PV (double word)	writes a PV double word (32 bit)
0	1	0	0	request PDE element	reads an element from the parameter description (PDE); the element to be read can be found in IND.

Reply identification (slave → master)

Bit no. 15 14 13 12				Function	Description
0	0	0	0	no reply	no reply
0	0	0	1	transmit PV (word)	transmits a PV word (16 bit)
0	0	1	0	transmit PV (double word)	transmits a PV word (32 bit)
0	0	1	1	transmit PDE element	transmits an element from the parameter description (PDE); the element to be transmitted can be found in IND.
0	1	1	1	job cannot be processed	error identification in PV, see error identification list

Connection between a job and its reply

Job identification				Reply identification					
Identification		Function		Identifica-tion		Function			
0	0	0	0	no job	0	0	0	0	no reply
0	0	0	1	request PV	0	0	0	1	transmits PV (word)
					0	0	1	0	transmits PV (double word)
0	0	1	0	change PV (word)	0	0	1	0	transmits PV (word)
0	0	1	1	change PV (double word)	0	0	1	1	transmits PV (double word)
0	1	0	0	request PDE element	0	0	1	1	transmits PDE element

PDE elements

Value	Meaning
1	parameter attribute
2	parameter info
5	parameter minimum value
6	parameter maximum value

Parameter attribute

Bit	Meaning
0 - 1	length
2 - 3	type
4 - 5	number
6 - 7	element type
8 - 11	format
12 - 15	decimal places

Length: Data length of an element in bytes

00	1 byte
01	2 bytes
10	4 bytes
11	8 bytes

Type: Data type of an element

00	SIGNED	complete number with polarity sign
01	UNSIGNED	complete number without polarity sign
10	FLOAT	floating point number

Number: Element number

00	FIXED	one element
01	VARIABLE	variable number of elements

Element type:

00	DATA
01	COMMAND

Format: Display format

0000	BIN	binary
0001	DEC	decimal
0010	HEX	hexadecimal
0100	NORM	floating point without exponent
0101	FIX	floating point with fixed exponent
0110	SCI	floating point, scientific
0111	ENG	floating point, engineering
1000	ASCII	ASCII character

Decimal places:

0000	0	no decimal places
....		
1111	15	15 decimal places

Info

Info is 32 bits long, but only the lower value 16 bits are used. The 16 higher value bits are reserved for future applications.

Bit	Meaning
0 ... 2	write-protection
3	save mode
4 - 15	not assigned

Write-protection:

000	UNPROTECTED	not protected
001	PROTECTED	write-protection level 1

Save mode:

0	NONSTORE
1	STORE

Error identification list

If jobs cannot be processed, the receiver transmits the reply identification „job cannot be processed“ and transfers the corresponding error identification in parameter value (PV):

Identification	Description
0	Invalid PN
1	Parameter cannot be altered
2	MIN/MAX limitation
3	Faulty IND
4	No array
5	Wrong data type
6	No setting allowed
7	Description element cannot be altered
:	:
100	Reserved
101	Undefined error
102	Service not implemented
103	Parameter format too big for PIV range
104	PDE element not available

Job/reply processing

Job/reply processing describes the temporal and functional sequence of data transmission for the PIV interface between the master and the slaves.

- The transmitter may only give one job to one slave and must then wait for the corresponding reply identification. As long as it is waiting for the reply identification it must repeat the job.
- The job/reply must be transmitted completely in one message.
- Every alteration of the job means a new job, to which the corresponding reply must be made. Job identification „no job“ receives the reply identification „no job“.
- If no information from the PIV interface is required in cyclic mode, the job „no reply“ must be set.
- If there are large time differences between the cyclic message sequence and reply preparation in the unit, the reply to „old job“ is sent during the transition phase between „old job“ and „new job“ until the new job is received and its corresponding reply given.
- In the case of replies which contain parameter values, the slave always replies, on repetition of the message, with the current value.
- On initial establishment of communication between master and slave, during the transition phase the slave can only reply with the identification „no reply“.
- If the transmitter does not receive a reply identification which belongs to its job from the receiver, a corresponding reaction must be triggered in the transmitter.
- The receiver does not expect confirmation from the transmitter that its reply has been received.
- Recognition of an existing job by the master:
The transmitter recognises the correct reply message by evaluating the reply identification, the parameter number, if necessary via the value in IND and the parameter value.
- Recognition of a new job by the slave:
Every job given by the transmitter after reception of a valid reply to an old job is recognised as a new job.
- If the master transmits a broadcast message, the slaves do not send a reply message to the master.

Index (IND)

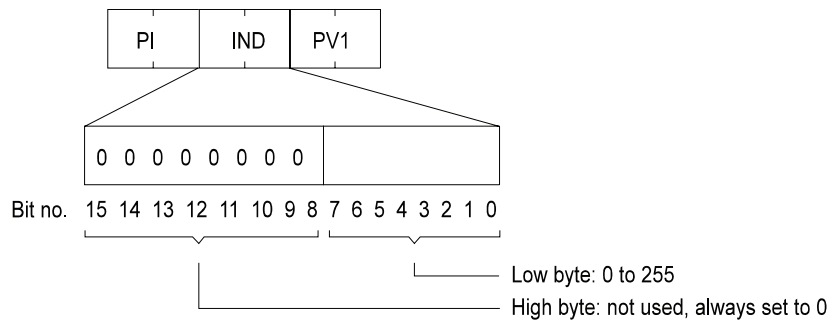

The index is used for writing and reading parameter descriptions.

In all other cases the index is carried as a „zero word“ in the message, i.e. all bits are set to 0.

Parameter value (PV)

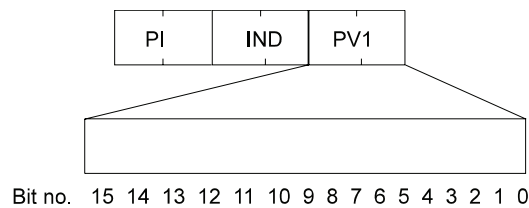

PV allocation is dependent on the existing job, or the corresponding reply.

PIV length for word sizes is always 3 words (PI, IND and PV)

PIV length for double word sizes is always 4 words (PI, IND and PV1 and PV2)

Structure of the PD range

The structure of the PD range is always the same in the sequence of its elements (= words) and only differs from its standard form by the length of the transmitted specified/actual values.

It covers a maximum of 3 words and a minimum of 0 words, i.e. no PD range in the net data block

Standard construction with specified/actual values as word size (PD number = 2):

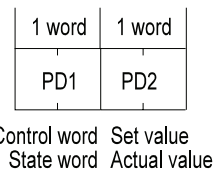

Standard structure with specified/actual values as double word size (PD number = 3):

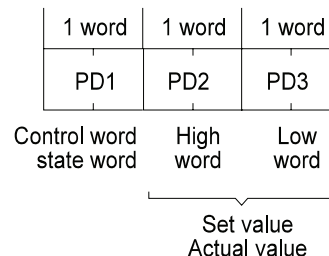

- Description of the individual PD elements

Control word and status word

The meaning of the bits in the control and status words is described in the drive manager under the parameters M control word (P120) and M status word (P121).

Specified/actual values

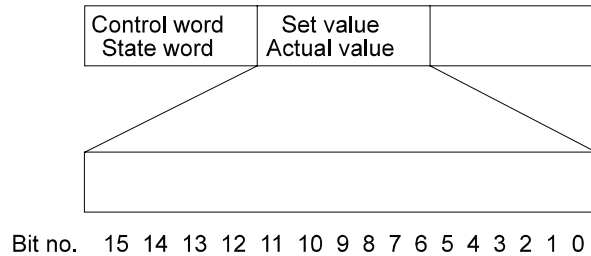

Transmission of specified and actual values in hex figures, where standardisation takes place according to the parameter.

Commissioning the bus system (fixed message length)

The following applies to commissioning communication with the USS[®] protocol with set message length:

- For communication between master and slave:
Job and reply messages have the same length, i.e. regarding their PIV range and their PD range.
- This length must be set to a fixed value before initial commissioning of the bus system and may not be altered during use.
- Fixed message length means fixed size of the net data block.
- The size setting of the net data block is via the 2 parameters USS[®] PIV number (ID no. 183) and USS[®] PD number (ID no. 184).
- If the master sets a job whose reply would exceed the set size of the PIV range, this job is answered with the reply identification „job cannot be processed“, e.g. the job „PV request double word“ cannot be processed with PV number = 3.
- Before setting the net data block size, specify which jobs are to be set by the master. The size of the PIV range is to be based on this. That is, if processing of double words is planned, the PIV range should always be set to 4 words, even if the processing of single words is likely to be more common.

Example messages:

- Example 1: PIV number = 3, PD number = 2
Assignment of word parameters or transmission of specified/actual word values is possible.

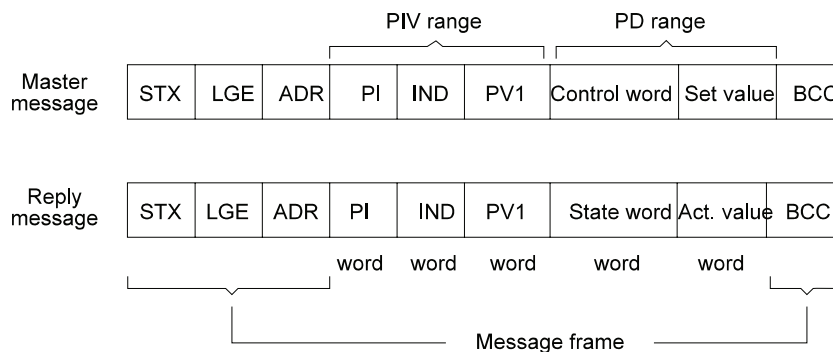

Parameter

- Example 2: PIV number = 0, PD number = 3

Transmission of specified/actual word and double word values is possible. Parameter assignment via PIV range is not possible.

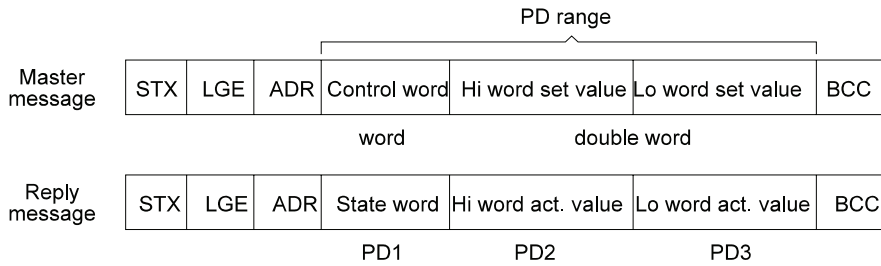

- Example 3: PIV number = 4, PD number = 0

Assignment of word and double word parameters is possible. Specified value entry and drive control is not possible.

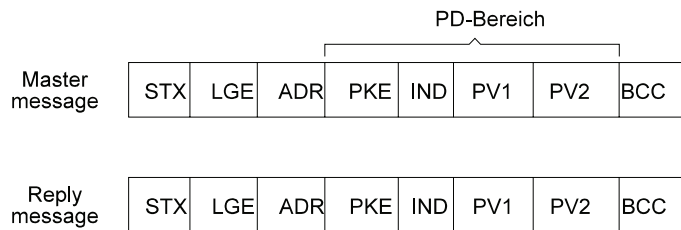

Parameter overview

Parameter	Name	Range min. ... max.	Unit	Display only
P180	USS® state	0000 ... FFFF		×
P181	USS® mode	0000 ... 0007		
P182	USS® baud rate	150 ... 19200	Baud	
P183	USS® PIV number	0 ... 4	Words	
P184	USS® PD number	0 ... 3	Words	
P185	USS® set value Pxxx	0 ... 700		×
P186	USS® actual value Pxxx	0 ... 700		×

Parameter description

P 180 USS[®] state

Displays the internal status of the module.

The module function is set via parameter M communication source (P126) of the drive manager. For further details, see the relevant chapter..

Bit no.	Meaning
0 - 3	0000: state STOP. Incoming messages are not answered 0001: state RUN. Message evaluation is active.
4	1: no message received at own address for longer than 1 s
5	1: no message traffic on the bus for longer than 5 s
6	reserved
7	1: faulty module initialisation
8	1: format error on actual value transfer (see P186)
9	1: format error on set value transfer (see P185)
10	1: error on reading actual value
11	1: error on writing set value
12 - 15	reserved

P 181 USS[®] mode

This parameter sets the USS[®] protocol mode.

Bit no.	Meaning
0	1: set/actual value standardization active, set and actual values are transmitted in % 0: set/actual value standardization inactive, set and actual values are transmitted in internal standardization (see internal standardization)
1	1: broadcast coding active 0: broadcast coding inactive
2	1: answer delay active 0: answer delay inactive
3 - 15	reserved

Specified and actual value standardisation is selected with bit no. 0.

Apart from specified and actual position values, all specified and actual value parameters are represented as relative sizes. With deactivated specified/actual value standardisation these parameters are represented in original standardisation in the message ($\pm 100.00\%$, ± 2048 etc.), with active standardisation they are referred to 4000h.

Broadcast coding is activated by bit no. 1.

In normal circumstances all of the maximum 32 bus participants are addressed when the broadcast-message is activated. By means of the Broadcast coding one can select for which drive this Broadcast message is set; only those specific drives react to the control word contained in the Broadcast message. The masking of this control word (with the masking of this control word (with the mask transmitted in the PV1 (PIV-range)) remains effective.

Following requirements must be satisfied for the use of Broadcast coding:

- USS[®] PIV number (P183) must be set → 3
- USS[®] PD number (P184) must be set → 3
- USS[®] mode (P181) bit no. 1 must be set = 1.

The significance of the Broadcast coding is indicated by the following example:

Assuming: PD number = 3, PIV number = 3

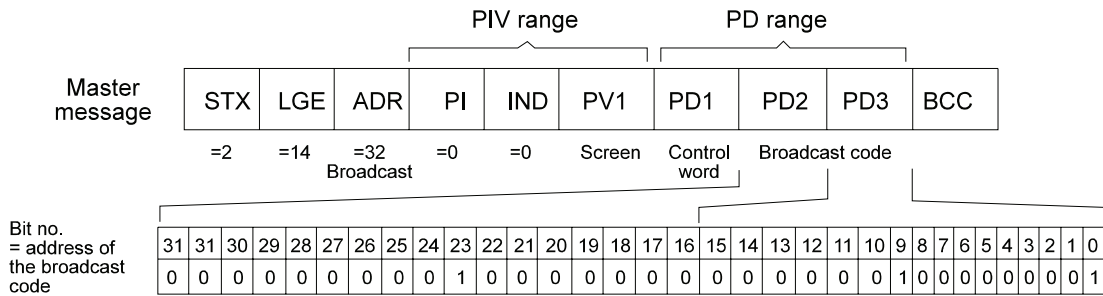

The Broadcast code is set in PD2 (low-word) and PD3 (high-word) and signifies, in this example, that the control word in PD1, masked with the value in PV1, must be accepted and executed by the bus participants with the address 0, 9 and 23. All other bus participants must disregard this information.

The answer delay is selected via bit no. 2

According to the specification of the USS[®] protocol the drive will transmit, after the reception of the master message, its answer message with a maximum delay of 2 ms. Within this short time span a thorough processing of the information contained in the master message will not always be possible (e.g. in PD range). Consequently a prepared answer message (with an incomplete content) is sent back to the master. The correct return answer is only then transmitted to the master in the next message-cycle.

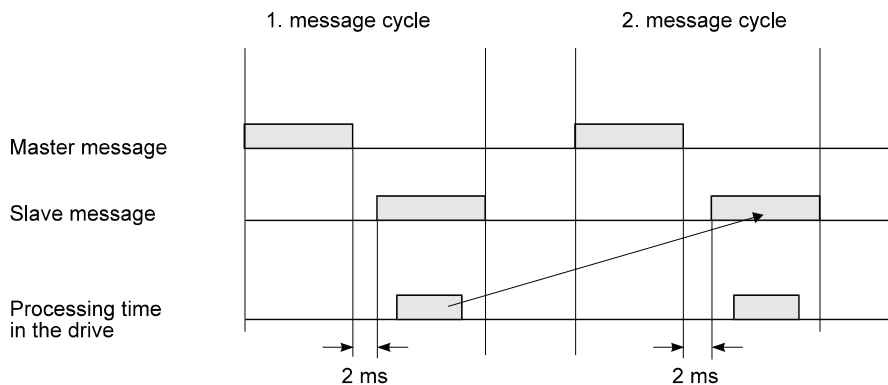

In activating the answer-delay the information contained within processed, after the reception of the master message (and straight after the answer message has been transmitted back to the master (see arrow). A message-cycle is thus saved, however, uncertainty occurs as to exactly when the answer message is transmitted. If the answer-delay is activated then the message timing will no longer correspond to the specification.

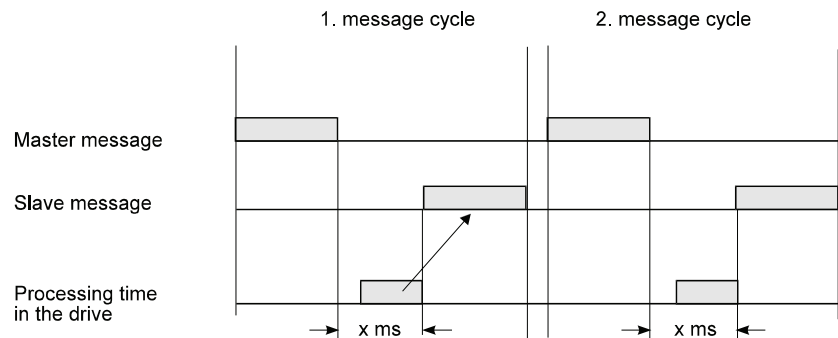

P 182 USS® baud rate

This parameter sets the baud rate for the RS485 interface.

P 183 USS® PIV number

This parameter sets the number of PIV elements available in the PIV range of the net data block. The specification always refers to PIV elements of word length.

Value	Meaning
0	0 words (no parameter assignment possible)
3	constantly 3 words (word parameter)
4	constantly 4 words (double word parameters)

P 184 USS® PD number

The amount of process data contained in the user data block can be influenced by this parameters. The entry is always PD elements with word length..

Value	Meaning
0	no process data
1	control word / status word is transmitted in PD1
2	control word / status word and 16 bit set/actual values
3	control word / status word and 32 bit set/actual values

P 185 USS[®] set value Pxxx

This parameter allows the selection of that drive parameter which is to be written with the set value from the master message (PD2, PD3). The following stipulation applies to the data exchange:

PD number	Actual value parameter format	Comments
0	16 / 32 bit	set value channel switched off
1	16 / 32 bit	set value channel switched off
2	16 bit	set value transmitted in PD2
2	32 bit	data transmission not possible, bit no. 9 is set in USS [®] state
3	16 bit	set value transmitted in PD3
3	32 bit	HI word of the set value transmitted in PD2 LO word of the set value transmitted in PD3

P 186 USS[®] actual value Pxxx

This parameter allows the selection of that drive parameter whose value is to be transmitted as the actual value in the reply message (PD2, PD3). The following stipulation applies to the data exchange.

PD number	Actual value parameter format	Comments
0	16 / 32 bit	actual value channel switched off
1	16 / 32 bit	actual value channel switched off
2	16 bit	actual value transmitted in PD2
2	32 bit	data transmission not possible, bit no. 8 is set in USS [®] state
3	16 bit	actual value transmitted in PD3
3	32 bit	HI word of the actual value transmitted in PD2 LO word of the actual value transmitted in PD3

7.31 BAPS Communication

Function

The module controls the communication of the controller with the various option cards via dual port RAM. Data exchange between the controller and the DP-RAM takes place according to the BAPS (Baumüller drives parallel interface) specification.

Parameter overview:

Parameter	Name	Range min. ... max.	Unit	Display only
P175	BAPS WD state	0000 ... FFFF		×
P176	BAPS C master command	0000 ... FFFF		×
P177	BAPS C slave acknowledgement	0000 ... FFFF		×
P178	BAPS C state	0000 ... FFFF		×

Parameter description

P 175 BAPS WD state

This parameter shows the state of working data communication

Value	Meaning
0	no communication
1	communication in operation

P 176 BAPS C master command

Command word of master.

Value	Meaning
00	no meaning
01	cyclic data exchange
02	write configuration initialise communication
03 ... FE	reserved
FF	no meaning

P 177 BAPS C slave acknowledgement

Acknowledgement by slave.

Value	Meaning
00	no meaning
01	set values read, actual value written
02	configuration / initialisation carried out correctly
03 ... 7F	reserved
80	illegal instruction received
81	no configuration / initialisation carried out
82	actual value cannot be read (configuration)
83	set value cannot be written (configuration)
84 ... FE	reserved
FF	no meaning

P 178 BAPS C state

State of cyclic communication.

Bit no.	Meaning
0 ... 3	0: communication inhibited 1: communication enabled
4	1: communication initialised
8	1: timeout

7.32 Additional Parameter

Function

These parameters are only used by the optional boards to store the data in the V-controller EEPROM.

Parameter overview

Parameter	Name	Range min. ... max.	Unit	Display only
P478	ZK 0	0000 ... 8000	-	
	.	.		
	.	.		
	.	.		
P499	ZK 31	0000 ... 8000	-	

7.33 Parameter List

	Parameter	Page	Standard value	Internal standardization
	P001 RFG output	137		
×	P002 RFG input 1	137	0.00 %	
×	P003 RFG ramp-up time 1	137	0.00 s	
×	P004 RFG input 2	137	0.00 %	
×	P005 RFG ramp-up time 2	137	0.00 s	
×	P006 RFG input 3	137	0.00 %	
×	P007 RFG ramp-up time 3	137	0.00 s	
×	P009 RFG time halt	137	0.00 s	
×	P010 RFG ramp-down time 1	137	0.00 s	
×	P011 RFG ramp-down time 2	137	0.00 s	
×	P012 RFG ramp-down time 3	137	0.00 s	
×	P013 RFG mode	137	0001	
	P014 RFG state	136		
×	P016 RFG rounding	137	0 ms	
×	P019 EM maximum speed	85	3000 U/min	
	P020 G1 sine	92		
	P021 G1 cosine	92		
	P022 G1 phi actual value	91		
	P023 G1 N actual value	90		
×	P024 G1 no. of graduation marks	90	512 Ink	
	P025 G1 state	88		
	P026 G1 sine offset	92	0.0000	
	P027 G1 cosine offset	92	0.0000	
	P028 G1 sine gain	92	1.0000	
	P029 G1 cosine gain	92	1.0000	
	P030 Mot phi mechanical	82		
×	P031 Mot mode	81	0	
	P032 Mot rho electrical	82		
×	P033 Mot no. of pole pairs	82	3	
×	P034 Mot rotating field	82	1	
×	P035 Mot locating angle	82	240.0 °	
	P036 Mot state	80		
×	P037 Mot delta I	82	5	
×	P038 N M limiter mode	99	0	
×	P039 Mot delta rho	82	5	
×	P040 G1 mode	89	0000	
	P041 G1 delta phi 16	91	0000 Inc	
	P042 G1 delta phi 32	91	0000 0000	
	P043 G1 Rev actual value	90		
	P044 G1 sine measured value	92		
	P045 G1 cosine measured value	92		
×	P046 G1 overspeed	93	115.00 %	
×	P047 N additional set value	99	0.00 %	
×	P048 I M additional set value	96	0.00 %	
×	P049 N J compensation	99	0.00 %	
	P050 N set value	99		
	P051 N actual value	99		
	P052 N controller output	99		
×	P053 N M limiter bipolar	100	100.00 %	

	Parameter	Page	Standard value	Internal standardization
×	P054 N M limiter Mot/TD1	100	100.00 %	
×	P055 N M limiter Gen/TD2	100	100.00 %	
×	P056 N block time	100	60.0 s	
×	P057 N P gain	98	10.0	
×	P058 N integral action time	99	25.0 ms	
	P059 N state	98		
	P060 N deviation	100		
×	P061 N limiter deviation	100	99.99 %	
×	P062 G1 N smoothing actual value	90	1.0 ms	
	P066 TM M loading	102		
×	P067 I M set value	95	0.00 %	
	P068 I Iq controller output	96		
	P069 I EMC set value	96		
	P070 I phase voltage U	97		
	P071 I Id set value	96		
	P072 I Id actual value	96		
	P073 I phase current U	97		
	P074 I phase current V	97		
	P075 I Uq-Sollwert	97		
	P076 I Ud set value	97		
	P077 I Id set value	97		
	P078 I Id actual value	97		
	P079 I state	95		
×	P080 I P gain	95	1.0	
×	P081 I integral action time	95	2.5 ms	
×	P082 Uq-/Ud limit	95	100.00 %	
	P083 I current offset U	97		
	P084 I current offset V	97		
	P086 I phase voltage V	97		
×	P087 PS Uz _k nominal	59	540 V	
×	P088 I _{2t} warning limit motor	76	100.00 %	
×	P089 I _{2t} time constant motor	76	0	
×	P090 PU mode	61	0000	
	P091 I _{2t} value motor	76	0.00 %	
	P092 TM Mact / Mn	102		
	P093 I _{2t} state	76		
×	P094 TM M > M2	102	90.00 %	
×	P095 TM time 2	102	0.000 s	
×	P096 TM M > M1	102	90.00 %	
	P097 TM time 1	102	0.000 s	
	P098 TM state	101		
	P099 I current actual value	97		
	P100 PWM phase U	67		
	P101 PWM phase V	67		
	P102 PWM phase W	67		
×	P103 PWM frequency	68	8.0 kHz	
×	P104 G2 N=0 threshold	93	1.00 %	
×	P105 G2 N>Nx ON threshold	93	100.00 %	
×	p106 G2 N>Nx OFF threshold	93	95.00 %	
×	P107 G1 N=0 threshold	93	1.00 %	
×	P108 G1 N>Nx ON threshold	93	100.00 %	

Parameter

	Parameter	Page	Standard value	Internal standardization
×	P109 G1 N>Nx OFF threshold	93	95.00 %	
	P110 PS state	59		
	P111 PS voltage Uzk	59		
×	P112 PS voltage failure time	60	3.000 s	
	P113 PU I max	63	2.5 A	
	P114 PU I nominal	63	2.5 A	
	P115 PU state	61		
×	P116 PU I limit	63	2.5 A	
	P117 PU type	62		
	P118 PU temperature	63		
×	P119 PU overload time	63	0 s	
	P120 M control word	117		
	P121 M state word	119		
×	P122 M desired operation mode	121	-3	
	P123 M actual operation mode	122		
	P124 M error code	123		
	P125 M error index	123		
×	P126 M communication source	123	0000	
×	P127 M communication monitoring	124	0000	
×	P128 M monitoring time	124	0 ms	
×	P129 M monitoring code	125	0	
×	P130 M HALT code	125	1	
×	P131 M RAPID HALT code	125	2	
	P132 M INHIBIT code	125	3	
×	P133 M SHUTDOWN code	126	3	
×	P134 M state bit no. 14	126	0000	
×	P135 M state bit no. 15	126	0000	
×	P136 M mode	123	0001	
	P137 M state 1	126		
×	P139 PU Ixt value	63	0	
	P140 SVG target Pxxx	139		
	P141 SVG output value	139		
×	P142 SVG set value 1	139	100.00 %	
×	P143 SVG set value 2	139	0.00 %	
×	P144 SVG set value 3	139	-100.00 %	
×	P145 SVG set value 4	139	0.00 %	
×	P146 SVG time 1	139	1.000 s	
×	P147 SVG time 2	139	1.000 s	
×	P148 SVG time 3	139	1.000 s	
×	P149 SVG time 4	139	1.000 s	
	P150 SVG state	139		
	P151 MT state	77		
×	P152 MT mode	78	0000	
×	P153 MT temperature	78		
×	P154 MT threshold 1	78	125 °C	
×	P155 MT threshold 2	78	125 °C	
×	P156 MT shutdown threshold	78	150 °C	
×	P157 MT hysteresis	78	5 °C	
	P159 OS value	134		
	P160 OS selection	134		
	P161 OS sampling time	133		

	Parameter	Page	Standard value	Internal standardization
	P162 OS message	133		
	P163 OS BUS6-VC SW release	134		
	P166 OS state	133		
×	P167 OS sync. slot	134	0 µs	
×	P168 OS sync. offset	134	0 µs	
×	P169 OS sync. tolerance	134	0	
	P170 SI state	173	0	
	P171 SI baud rate	174	9600 Baud	
×	P172 SI mode	174	3	
	P173 SI array state	174		
	P174 OS user SW	134		
	P175 BAPS WD state	189		
	P176 BAPS C master command	189		
	P177 BAPS C slave acknowledgement	190		
	P178 BAPS C state	190		
	P180 USS® state	185		
×	P181 USS® mode	185	0000	
×	P182 USS® baud rate	187	9600 Baud	
×	P183 USS® PIV number	187	3 Worte	
×	P184 USS® PD number	187	2 Worte	
×	P185 USS® set value Pxxx	188	0	
×	P186 USS® actual value Pxxx	188	0	
	P190 DSM command	130		
	P191 DSM state	130		
	P192 DSM message	130		
	P193 DSM DS name	131		
	P194 DSM DS article no.	131		
	P195 DSM message Pxxx	131		
	P196 DSM load data set	131		
	P197 DSM DS program cycles	131		
	P198 DSM key	132		
	P200 P state	104		
×	P201 P mode	104	0000	
×	P202 P Kv factor	104	10 1/s	
×	P203 P deviation limiter dynamic	107	0000 0800 Inc	
×	P204 P N limiter bipolar	106	100.00 %	
	P205 P rev set value	106		
	P206 P phi set value	106		
×	P207 P N precontrol	105	100.00 %	
	P208 P set value	105		
	P209 P actual value	105		
	P210 P deviation	105		
	P211 P controller output	105		
×	P212 P deviation limiter static	106	0000 0100 Inc	
×	P213 P N precontrol smoothing	105	1.0 ms	
×	P214 P time	107	1.000 s	
	P218 P rev actual value	106		
	P219 P phi actual value	106		
	P220 P N precontrol output	105		
	P224 EM kp	85		
	P225 EM state	83		

Parameter

	Parameter	Page	Standard value	Internal standardization
×	P226 EM mode	84	000D	
×	P227 EM no. of graduation marks	85	1024	
	P228 EM encoder types	84		
×	P229 EM offset zero impulse	85	0000 Inc	
	P230 G2 sine measured value	92		
	P231 G2 cosine measured value	92		
	P232 G2 sine offset	92		
	P233 G2 cosine offset	92		
	P234 G2 sine gain	92		
	P235 G2 cosine gain	92		
	P236 G2 sine	92		
	P237 G2 cosine	92		
×	P238 G2 N smoothing actual value	90	1.0 ms	
×	P239 G2 overspeed	93	115.00 %	
	P240 G2 state	88		
×	P241 G2 mode	89	0000	
×	P242 G2 no. of graduation marks	90	512 Inc	
	P243 G2 N actual value	90		
	P244 G2 phi actual value	91		
	P247 G2 delta phi 16	91	0000 Inc	
	P248 G2 delta phi 32	91	0000 0000	
	P249 G2 Rev actual value	90		
	P250 SC state	142		
×	P251 SC mode	143	0000	
×	P252 SC compensation factor	145	1	
×	P253 SC tolerance	145	1.000 s	
×	P254 SC sync delta	145	0000 0000	
×	P255 SC following axis rpm	143	1000	
×	P256 SC leading axis rpm	143	1000	
	P257 SC position set value	144	0000 0000 Inc	
	P258 SC phi set value	144	0000 0000	
×	P259 SC tolerance time	145	1.000 s	
×	P260 MM magnetizing current Id	70	0.0 A	
×	P261 MM motor nominal current	70	2.5 A	
×	P262 MM nominal speed	71	1500 U/min	
×	P263 MM nominal frequency	71	52.6 V	
×	P264 MM Kp flow controller	71	1.0	
×	P265 MM Tn flow controller	71	30 ms	
	P266 MM flux set value	71		
	P267 MM flux actual value	71		
×	P268 MM Ke factor	70	0 V/1000	
×	P269 MM mode	71	0	
×	P270 EA mode	140	0	
×	P271 EA motor potentiometer +	140	0	
×	P272 EA motor potentiometer -	141	0	
×	P273 EA motor potentiometer Pxxx	141	2	
×	P274 EA motor potentiometer dynamics	141	1	
×	P275 EA motor potentiometer increment	141	1 %	
	P276 EA motor potentiometer value	141		
×	P277 AI 1 input channel	148	0	
×	P278 AI 1 smoothing	148	1 ms	

	Parameter	Page	Standard value	Internal standardization
×	P279 AI 1 scaling	148	1.00	
×	P280 AI 1 target Pxxx	149	0	
×	P281 AI 1 offset	149	0.00 %	
×	P282 AI 1 threshold value	149	0.00 %	
	P283 AI 1 value	149		
×	P284 AI 2 input channel	148	1	
×	P285 AI 2 smoothing	148	1 ms	
×	P286 AI 2 scaling	148	1.00	
×	P287 AI 2 target Pxxx	149	0	
×	P288 AI 2 offset	149	0.00 %	
×	P289 AI 2 threshold value	149	0.00 %	
	P290 AI 2 value	149		
×	P291 MM MGen1 Nnominal	73	95 %	
×	P292 MM MGen2 12000 rpm	73	30 %	
×	P293 MM Tr rotor actual value	71	10 ms	
×	P294 MM frequency temperature 1	72	52.0 Hz	
×	P295 MM temperature 1	72	20	
×	P296 MM temperature 2	72	80 °C	
	P297 MM frequency = f (temp)	72		
×	P330 AO 1 source Pxxx	152	0	
×	P331 AO 1 offset	152	0 Dig	
×	P332 AO 1 scaling	152	1 Dig/V	
×	P334 AO 2 source Pxxx	152	0	
×	P335 AO 2 offset	152	0	
×	P336 AO 2 scaling	152	1 Dig/V	
×	P337 AO test value	152	0.000 V	
	P338 AO state	151		
×	P342 DI 4 target Pxxx	160	120	
×	P343 DI 4 bit selection	160	0008	
×	P344 DI 4 LOW pattern	160	0000	
×	P345 DI 4 HIGH pattern	160	0008	
×	P350 LED 1 source Pxxx	155	0	
×	P351 LED 1 bit selection	155	0	
×	P352 LED 1 bit pattern	155	0	
×	P353 LED 2 source Pxxx	155	0	
×	P354 LED 2 bit selection	155	0	
×	P355 LED 2 bit pattern	155	0	
×	P356 LED 3 source Pxxx	155	0	
×	P357 LED 3 bit selection	155	0	
×	P358 LED 3 bit pattern	155	0	
×	P359 LED 4 source Pxxx	155	0	
×	P360 LED 4 bit selection	155	0	
×	P361 LED 4 bit pattern	155	0	
	P362 LED state	155		
×	P370 DI 1 target Pxxx	160	0	
×	P371 DI 1 bit selection	160	0	
×	P372 DI 1 LOW pattern	160	0	
×	P373 DI 1 HIGH pattern	160	0	
×	P374 DI 2 target Pxxx	160	0	
×	P375 DI 2 bit selection	160	0	
×	P376 DI 2 LOW pattern	160	0	

Parameter

	Parameter	Page	Standard value	Internal standardization
×	P377 DI 2 HIGH pattern	160	0	
×	P378 DI 3 target Pxxx	160	120	
×	P379 DI 3 bit selection	160	0080	
×	P380 DI 3 LOW pattern	160	0000	
×	P381 DI 3 HIGH pattern	160	0080	
	P382 DI state	159		
×	P383 DO 1 source Pxxx	162	0	
×	P384 DO 1 bit selection	162	0	
×	P385 DO 1 bit pattern	162	0	
×	P386 DO 2 source Pxxx	162	0	
×	P387 DO 2 bit selection	162	0	
×	P388 DO 2 bit pattern	162	0	
×	P389 DO 3 source Pxxx	162	0	
×	P390 DO 3 bit selection	162	0	
×	P391 DO 3 bit pattern	162	0	
	P392 DO state	163		
	P500 XDI state	165		
×	P501 XDI 1 target Pxxx	165	0	
×	P502 XDI 1 bit selection	166	0	
×	P503 XDI 1 LOW pattern	166	0	
×	P504 XDI 1 HIGH pattern	166	0	
×	P505 XDI 2 target Pxxx	165	0	
×	P506 XDI 2 bit selection	166	0	
×	P507 XDI 2 LOW pattern	166	0	
×	P508 XDI 2 HIGH pattern	166	0	
×	P509 XDI 3 target Pxxx	165	0	
×	P510 XDI 3 bit selection	166	0	
×	P511 XDI 3 LOW pattern	166	0	
×	P512 XDI 3 HIGH pattern	166	0	
×	P513 XDI 4 target Pxxx	165	0	
×	P514 XDI 4 bit selection	166	0	
×	P515 XDI 4 LOW pattern	166	0	
×	P516 XDI 4 HIGH pattern	166	0	
×	P517 XDI 5 target Pxxx	165	0	
×	P518 XDI 5 bit selection	166	0	
×	P519 XDI 5 LOW pattern	166	0	
×	P520 XDI 5 HIGH pattern	166	0	
×	P521 XDI 6 target Pxxx	165	0	
×	P522 XDI 6 bit selection	166	0	
×	P523 XDI 6 LOW pattern	166	0	
×	P524 XDI 6 HIGH pattern	166	0	
×	P525 XDI 7 target Pxxx	165	0	
	P526 XDI 7 bit selection	166	0	
×	P527 XDI 7 LOW pattern	166	0	
×	P528 XDI 7 HIGH pattern	166	0	
×	P529 XDI 8 target Pxxx	165	0	
×	P530 XDI 8 bit selection	166	0	
×	P531 XDI 8 LOW pattern	166	0	
×	P532 XDI 8 HIGH pattern	166	0	
	P533 XDO state	168		
×	P535 XDO 1 source Pxxx	168	0	

	Parameter	Page	Standard value	Internal standardization
×	P536 XDO 1 bit selection	168	0	
×	P537 XDO 1 bit pattern	169	0	
×	P538 XDO 2 source Pxxx	168	0	
×	P539 XDO 2 bit selection	168	0	
×	P540 XDO 2 bit pattern	169	0	
×	P541 XDO 3 source Pxxx	168	0	
×	P542 XDO 3 bit selection	168	0	
×	P543 XDO 3 bit pattern	169	0	
×	P544 XDO 4 source Pxxx	168	0	
×	P545 XDO 4 bit selection	168	0	
×	P546 XDO 4 bit pattern	169	0	
×	P547 XDO 5 source Pxxx	168	0	
×	P548 XDO 5 bit selection	168	0	
×	P549 XDO 5 bit pattern	169	0	
×	P550 XDO 6 source Pxxx	168	0	
×	P551 XDO 6 bit selection	168	0	
×	P552 XDO 6 bit pattern	169	0	
×	P553 XDO 7 source Pxxx	168	0	
×	P554 XDO 7 bit selection	168	0	
×	P555 XDO 7 bit pattern	169	0	
×	P556 XDO 8 source Pxxx	168	0	
×	P557 XDO 8 bit selection	168	0	
×	P558 XDO 8 bit pattern	169	0	

×: parameter is saved in data set

8 MAINTENANCE



WARNING

The equipment carries a dangerously high voltage and has dangerous rotating parts (fans). Ignoring the safety and warning information may result in death, severe personal injury or damage to property.

You may only carry out maintenance when the unit is deenergized..

Do not begin work on the power stage and the intermediate circuit until you have made sure that the unit is not carrying potential or a voltage (remanent charge).

When dismantling safety devices during commissioning, repair and maintenance work, you must ensure that the machine is taken out of commission exactly as specified. You must remount and check safety equipment immediately after completing commissioning, repair and maintenance work..

After carrying out any work involving intervention in the machine – regardless of whether this involves the motor, the actual value acquisition or the power converter – the owner must carry out acceptance testing and document it chronologically in the machine log. Failure to do this may result in the owner being faced with consequences relating to liability legislation.

Do not start work on the power unit, intermediate circuit until you have made sure that the unit is not carrying potential or a voltage (remanent charge).

We cannot guarantee the product documentation is completely error-free unless this is expressly indicated in our General Conditions of Business and Delivery.

8.1 Maintenance Information

The units supplied are maintenance-free.

Prohibition of unauthorized modifications

For safety reasons, unauthorized additions or modifications to the drive are not allowed.

8.2 Error Messages

In the event of an error, parameter M error code (P124) indicates the appropriate error code. This error is acknowledged when bit Reset disturbance in M control word (P120) is set from 0 to 1. If there is more than one error, the system shows the next one immediately after acknowledgement.

- **Drive Manager Function Module (Error ID 00xx)**

Error ID	Error Text	Meaning	Remedy
0001 _{hex}	BASS protocol timeout	The communications source set in P124 has not responded for longer than the timeout set in P128.	Check communications (cables, daughterboard, etc.)
0002 _{hex}	USS protocol timeout		
0003 _{hex}	Dual-Port RAM timeout (cyclical data)		
0004 _{hex}	Dual-Port RAM timeout (working data)		
0005 _{hex}	System boot procedure	An error was determined while reading the boot data set from the EEPROM. You can get more information about the type of error by referring to parameter DSM Message (P192). This disturbance usually occurs if you replaced the controller firmware with firmware that is incompatible.	You should carefully check the data set in the controller's RAM and then program it in the EEPROM as the boot data set.
0010 _{hex}	Error switch (program error)	Only meaningful for software developers	

- **Power Supply Function Module (Error ID 01xx)**

Error ID	Error Text	Meaning	Remedy
0110 _{hex}	Disturbance in power supply unit	No ready for use signal from supply unit.	Check the power supply. Reset the error memory in the power supply unit (refer to the power supply unit's operating instructions)

- **Power Unit Function Module (Error ID 02xx)**

Error ID	Error Text	Meaning	Remedy
0201 _{hex}	Overvoltage Uz _k	The bus voltage, U _{ZK} , has exceeded a value of 800 V ± 1%	Check the ballast resistor
0202 _{hex}	Overcurrent	At least one of the power unit's three phase currents has overwritten the value of	Check the current controller's setting
0203 _{hex}	Error current	An error current was determined in the power unit that exceeded a specific amount. (For more detailed information, refer to the power unit description.)	Check the motor cables for a ground fault
0204 _{hex}	Disturbance in auxiliary voltage supply	There is no power supply for transistor control in the power unit.	Check control of the safety relay
0205 _{hex}	Overtemperature of power unit	The temperature of the power unit has risen above 85° C.	The disturbance cannot be acknowledged until the power unit temperature shown in P118 has fallen below 85° C.
0206 _{hex}	Disturbance in safety relay	The safety relay in the power unit is OFF even though it should be ON. This means that the auxiliary voltage supply for transistor control is deactivated.	Check control of the safety relay
0207 _{hex} 0208 _{hex} 0209 _{hex} 020A _{hex} 020B _{hex} 020C _{hex} 020D _{hex}	Transistor error (group message) Phase U top Phase U bottom Phase V top Phase V bottom Phase W top Phase W bottom	U _{CE} monitoring of one or more power transistors has tripped due, for example, to a short circuit or ground fault or because of defects in the transistor.	Check the motor cables for a short circuit or ground fault. Allow the power unit to cool down. If the disturbance keeps occurring, replace the power unit.
020E _{hex}	Power unit ID unknown	The control unit does not know the read identifier	Read off the power unit version from the rating plate and compare it with the list in P117. The error cannot be acknowledged.
020F _{hex}	Wrong power unit type	The stored power unit type does not match the one the system read, e.g. because no data set has been stored yet or you plugged the control unit into another power unit.	Check the parameterization and, if necessary, change it. Save the data set and acknowledge the error.
0210 _{hex}	Disturbance in power unit	The ready for use signal from the power unit is missing even though there are no other power unit disturbance messages.	

- Encoder Manager Function Module (Error ID 03xx)

Error ID	Error Text	Meaning	Remedy
0301 _{hex}	Overspeed of encoder 1	Evaluation has determined a speed actual value (P023) that is greater than the overspeed value (P046)	Check the encoder cable. Check the speed controller settings.
0302 _{hex}	Overspeed of encoder 2	Encoder has determined a speed actual value (P243) that is greater than the overspeed value (P239)	Check the encoder cable. Check the speed controller settings.
0303 _{hex}	Absolute position encoder 1 unknown (rotor position)	The error occurs in conjunction with operation of synchronous control on these encoders in the following cases: 1. At initialization of the encoder, it was not possible to read the absolute position from the encoder (e.g. due to the encoder adaptor module, lack of communication).	
0304 _{hex}	Absolute position encoder 2 unknown (rotor position)	2. The encoder has no absolute position information (e.g. incremental encoders with sinus or square wave signals).	

- Overload Monitoring Function Module (Error ID 04xx)

Error ID	Error Text	Meaning	Remedy
0401 _{hex}	I ² t monitoring of motor	Calculated I (P091) is greater than 100%	Leave the drive in the inhibited status until the I ² t actual value (P091) drops below 100%.

- Motor Temperature Function Module (Error ID 05xx)

Error ID	Error Text	Meaning	Remedy
0501 _{hex}	Overtemperature of motor	P152 = 3 (PTC thermistor) The motor temperature has risen to such an extent that the PTC thermistor has become highly resistant. P152 = 1 (sensor) The motor temperature has exceeded the shutdown threshold (P156). This disturbance can also occur if motor temperature acquisition is interrupted during operation.	Allow the motor to cool down until the motor temperature has dropped below the limit value. Check the encoder cable and the temperature sensor (see motor temperature connector X28)

- **Position Controller Function Module (Error ID 06xx)**

Error ID	Error Text	Meaning	Remedy
0601 _{hex}	Deviation, dynamic	In motion, e.g. positioning, synchronous operation, the deviation (P210) has become greater than the dynamic deviation error limit (P203).	Check the settings of the dynamic deviation limit and, if necessary, correct them. Reset the error enable for the dynamic deviation in mode parameter P201, bit number 0.
0602 _{hex}	Deviation, static	At standstill (e.g. target position reached, n=0), the deviation (P210) has become greater than the static deviation error limit (P212).	Check the settings of the static deviation limit and, if necessary, correct them. Reset the error enable for the dynamic deviation in mode parameter P201, bit number 1.

- **Speed Controller Function Module (Error ID 07xx)**

Error ID	Error Text	Meaning	Remedy
0702 _{hex}	Blocking monitoring	During the blocking time set in P056, the drive was stationary with maximum torque of N = 0.	Check the drive machine for blocking

- **Encoder 1 Function Module (Error ID 08xx)**

Error ID	Error Text	Meaning	Remedy
0801 _{hex} *)	Invalid module code	The adapter module's code is not known	The adapter module is either not fitted or not supported in this version of the firmware
0802 _{hex} *)	Wrong adapter module	The encoder adapter in the unit is not suitable for the desired encoder type and communications protocol settings.	Change the settings in the encoder mode or use another adapter
0803 _{hex} *)	No communication with the encoder	Reading the absolute position from the encoder did not function.	Check the encoder cable, on the motor and unit sides.
0804 _{hex} **)	Wire break encoder 1	The encoder signals are useless for evaluation.	Check the encoder cable, on the motor and unit sides.

- **Data Set Management Function Module (Error ID 09xx)**

Error ID	Error Text	Meaning	Remedy
0901 _{hex}	EEPROM copy error	A data difference was determined at copying of the EEPROM during initialization of data set management	This error cannot be acknowledged and you can only eliminate it by switching the electronics supply off and on again. If the error occurs repeatedly, this indicates that there is a defect in the controller hardware.
0902 _{hex}	Missing boot data set	There is no boot data set (DS no. 0) in the EEPROM	You must create the boot data set in RAM and then save it to the EEPROM.
0903 _{hex}	Checksum error in boot data set	At checking of the boot data set, the system calculated a different checksum than the one that was expected, i.e. a boot data set is present but it is invalid due to data corruption.	You must create the boot data set in RAM and then save it to the EEPROM.

- **Encoder 2 Function Module (Error ID 0Axx)**

Error ID	Error Text	Meaning	Remedy
0A01 _{hex} *)	Invalid module code	The adapter module's code is not known	The adapter module is either not fitted or not supported in this version of the firmware
0A02 _{hex} *)	Wrong adapter module	The encoder adapter in the unit is not suitable for the desired encoder type and communications protocol settings.	Change the settings in the encoder mode or use another adapter
0A03 _{hex} *)	No communication with the encoder	Reading the absolute position from the encoder did not function.	Check the encoder cable, on the motor and unit sides.
0A04 _{hex} **)	Wire break encoder 1	The encoder signals are useless for evaluation.	Check the encoder cable, on the motor and unit sides.

*) Errors cannot be acknowledged.

**) After acknowledgement, the encoder is reinitialized; in this connection, the reference to a reference point can be lost.

- **Operating System Function Module (Error ID 0Bxx)**

Error ID	Error Text	Meaning	Remedy
0B01 _{hex}	Main program computing time exceeded		P160 selection = 0, P169 value = 0, Store the data set again and acknowledge the error.
0B02 _{hex}	Task computing time exceeded		
0B03 _{hex}	Sync. IR computing time exceeded		
0B04 _{hex} *	DSP computing time exceeded		

*) Errors cannot be acknowledged.

9 APPENDIX

9.1 Manufacturer Declaration

HERSTELLERERKLÄRUNG IN SINNE DER EG-MASCHINENRICHTLINIE 89/392/EWG, ANHANG IIB

Manufacturer Declaration in Accordance with the EC-Machine Guidelines 89/392/EEC, Appendix II B

Hiermit erklären wir, dass es sich bei dieser Lieferung um die nachfolgend bezeichnete Maschinenkomponente handelt und dass ihre Inbetriebnahme solange untersagt ist, bis festgestellt wurde, dass die Maschine, in die diese Komponente eingebaut ist, den Bestimmungen der EG-Maschinenrichtlinie 89/392/EWG, Anhang II B entspricht.

We herewith declare that this delivery includes the following specified machine component and that its putting into operation is prohibited until the declaration is made that the machine, in which this component is built in, complies with the regulations of the EC-machine guideline 89/392/EWG, appendix II B.

Bezeichnung der Maschinenkomponente:
Specification of the machine component:

Typenbezeichnung:
Type:

V-Regler (BUS 6 VC)

BUS 6 V - - - - -

Nürnberg, 15.12.2004

Hersteller-Unterschrift:

Signature of the Manufacturer:



Andreas Baumüller
Geschäftsführer
Head Division



i.A. Dr. Heidrich
Entwicklungsleiter
Head of development

Seite 1 von 1 / page 1 of 1

9.2 Conditions of Business and Delivery

1. Scope
- 1.1 Deliveries and performance provided by Baumüller and offers made by Baumüller are exclusively and completely subject to these general terms and conditions (from now on referred to as "these terms"). Unless a mutual agreement has been made which differs from this statement, these terms also apply to future business relationships.
- 1.2 If a customer places an order with Baumüller, this implies that these terms are accepted. Any counterconfirmations made by persons or legal persons placing an order with Baumüller with reference to their own general terms and conditions or their terms and conditions of purchase are thereby objected to.
- 1.3 Supplements or modifications to these terms require written consent from Baumüller in order to take effect.
2. Offer and Copyright
- 2.1 Offers made by Baumüller are subject to confirmation and not binding. Supplements, modifications or ancillary agreements require written consent from Baumüller in order to take effect.
- 2.2 Any pictures, drawings, measures, weights or other performance specifications are only binding if this is explicitly stipulated in writing. Drawings, dimensional drawings and descriptions of projects are subject to the copyright of Baumüller and must neither be copied nor revealed to third parties without prior written consent from Baumüller. Baumüller reserves the right to demand that these objects are immediately returned to Baumüller if they are not used for orders to Baumüller.
- 2.3 The purchaser must not use any process engineering knowledge revealed to him in his business relationship with Baumüller for his own purposes and must not reveal that knowledge to third parties. Any violation of this condition makes the purchaser (violation) liable for damages of an amount of DM 70,000.
3. Scope and Term of Delivery
- 3.1 The deadlines and terms specified by Baumüller are not binding unless explicitly specified otherwise in a written agreement.
- 3.2 The delivery term begins at one of the points in time listed below:
 - Date of confirmation of order
 - Date on which the purchaser meets all of the technical, commercial or other prerequisites he is obliged to meet
 - Date on which a downpayment or security required prior to delivery of the merchandise is furnished by the purchaser
 - If the stipulated downpayments to Baumüller are made delayed, the delivery term is extended proportionally.
- 3.3 Baumüller has the right to make partial deliveries and provide partial performance and to issue partial invoices for these deliveries or performance at any time of their choice. Excess volume or short deliveries up to 5% of the delivery quantity are permitted. The amount charged is calculated according to the delivery quantity.
- 3.4 Baumüller is not responsible for delayed delivery or performance or the inability to deliver or perform due to acts of god or force majeure or other events which make it impossible or more difficult for Baumüller to deliver - e.g. war, problems in the provision of materials which arise after the time the offer has been made, malfunctions, strike, lockout, personnel short-age, shortages of means of transportation, instructions issued by the authorities etc. which occur at suppliers of Baumüller or their sub-suppliers. Therefore, Baumüller has the right to postpone deliveries or performance by the duration of the problem plus an appropriate startup time and Baumüller also has the right to withdraw from the contract partially or completely. If the problems persist for more than 3 months the purchaser has the right to withdraw from that part of the contract which has not yet been fulfilled after having fixed an appropriate extension of the time limit.
- 3.5 The deadline is considered to have been met if the object to be delivered leaves the storage facility on the fixed date or if the purchaser is informed of its availability for shipment on the fixed date.
- 3.6 Baumüller or subcontractors of Baumüller will install and assemble the delivered objects exclusively subject to conditions and terms separately agreed upon not later than 4 weeks before delivery.
4. Passage of risk, acceptance, packing
- 4.1 Delivery is made free carrier (FRC, INCOTERM 1980). The goods are packed at the discretion of Baumüller at the costs of the customer. The risk is passed to the customer as soon as the consignment has been handed over to the person carrying out the transport or has left the store.
- 4.2 If the shipment is delayed or becomes impossible due to reasons for which Baumüller is not responsible, the risk is passed to the customer with the notification of readiness for shipment if the delivery is stipulated to be carried out upon call-forward notice, the goods are regarded as called off at the latest one year after the date of order.
- 4.3 Special acceptance conditions must be defined at conclusion of the contract at the latest. The acceptance test has to take place in the works of Baumüller. The costs for the acceptance test will be charged to the customer. If the customer omits the acceptance test, the goods are regarded as delivered as stipulated when they leave our works.
5. Prices and terms of payment
- 5.1 The prices stipulated by Baumüller in the order confirmation plus the respective legal value added tax apply. Additional deliveries and services will be separately invoiced. The prices are valid ex works or store excluding packing.
- 5.2 If not otherwise agreed upon, the prices stipulated in the order confirmation are binding for 30 days only.
- 5.3 Payments shall be made in cash without any deductions free paying office of the vendor in the currency agreed upon. Bills of exchange and checks are only accepted on account of payment. The customer has to bear any costs and bank charges arising thereof. A payment is regarded as made only, if the amount is available to Baumüller. In case of payment by check, the payment is regarded as made when the check has been irrevocably cashed.
- 5.4 Invoices are to be paid without deductions within 30 days from the date of issue. Baumüller is entitled to enter payments of the customer on older open invoices in spite of deviating instructions by the customer. If costs and interests have arisen. Baumüller is entitled to enter the payment first on the costs, then on the interests and last on the main service.
- 5.5 The customer is entitled to offset, to retain or reduce the payment - independent of notices of complaint or possible counterclaims - only, if Baumüller has explicitly agreed or if the counterclaims have been legally verified.
- 5.6 If payments are delayed, Baumüller is entitled to charge interest on arrears at a rate corresponding to the interest rate for open credits in current account, however, at least corresponding to the current discount rate of the Deutsche Bundesbank. This does not affect the assertion of another damage caused by delayed payment.
- 5.7 If the customer fails to meet his payment obligations, especially if he does not cash a check or stops his payment or if Baumüller is informed of other circumstances making the credit worthiness of the customer uncertain. Baumüller is entitled to demand advance payments or securities before delivery or to invoice the total remaining amount in the case that instalments had been previously agreed upon.
6. Retention of ownership
- 6.1 Until all claims for present or future relations have been satisfied, Baumüller can at any time demand securities from the customer. Baumüller will arbitrarily release provided securities if the value of the securities continuously exceeds the claims by more than 20%.
- 6.2 Any goods delivered remain property of Baumüller until payment has been made in full (= delivery under proviso). Goods delivered under proviso are processed or reconfigured at the purchaser's for Baumüller as the manufacturer but without additional obligations. If Baumüller ownership rights are nullified because the goods are integrated into or assembled to other objects, a portion of the ownership rights of the purchaser to that object covering the amount in question is transferred to Baumüller. The purchaser keeps the property of Baumüller in custody for no charges.
- 6.3 The purchaser has - unless he is in delay of payment - the right to process and sell the goods delivered under proviso in normal business. However, he must not distress or transfer ownership of the goods delivered under proviso by way of security. The purchaser transfers any receivables arising from the selling of the goods or from another legal reason completely to Baumüller when the goods are received. Baumüller revocably entitles the purchaser to collect the receivables transferred to Baumüller on the account of Baumüller under his own name. Upon request by Baumüller, the purchaser will reveal the transfer.
- 6.4 If third parties access the goods delivered under proviso, the purchaser will inform them about the ownership rights of Baumüller and will immediately inform Baumüller. Any expenses and damages are paid for by the purchaser.
- 6.5 If the purchaser violates any of the terms of the contract - in particular if he is in delay of payment - Baumüller has the right to reposes the goods delivered under proviso at the cost of the purchaser or Baumüller has the right to require transfer of the restitution title the purchaser has against third parties. If Baumüller repossesses or distresses the goods delivered under proviso, this does not mean that Baumüller withdraws from the contract. The right to receive payment for damages remains unaffected by this.
7. Warranty
- 7.1 If the delivered products are faulty or fail to have properties guaranteed by Baumüller or if the products become defective during the warranty period because of faults which occurred or were caused during the process of manufacturing or in case of material defects Baumüller supplies - excluding any other warranty claims by the purchaser, in particular excluding any direct or indirect secondary claims for damages from the purchaser - replacement parts of their own choice or rectifies defects. Multiple rectification is permitted. For essential products and parts not manufactured by Baumüller - in particular if the purchaser has made specifications - the liability of Baumüller is limited to the transfer of the claims for damages Baumüller has against the supplier of these products or parts.
- 7.2 The warranty period is 12 months and starts on the day the goods are shipped to the purchaser or - if the delivery scope is installed and assembled by Baumüller - the warranty period starts on the day the installation is complete.
- 7.3 The purchaser is obliged to inspect the delivered goods for damages or defects immediately or at least within two weeks after receiving the goods or - if the product is installed - within two weeks after completion of the installation process. In addition, he is obliged to inform Baumüller of any damages, defects or losses immediately by sending a report created by the carrier or a corresponding report in the form of a statement in lieu of an oath which must have been signed by two witnesses and by the purchaser. In addition, Baumüller must be informed in writing of obvious defects or shortcomings immediately or at least within two weeks after delivery. If shortcomings and defects cannot be detected in thorough tests within two weeks and are found at a later time, Baumüller must be informed of these problems immediately after they are detected. Defective products must be submitted to Baumüller for testing on request in the condition in which the defect was detected. Defective products must not be returned to Baumüller unless Baumüller requests in writing that the products are returned. Failure to observe any of the regulations specified above nullifies all warranty claims against Baumüller.
- 7.4 If rectification or replacements are not successful within an appropriate period of time, the purchaser may either request reduction of the purchase price or cancellation of the delivery contract.
- 7.5 If Baumüller manufactures a product based on design specifications, drawings, models or other specifications provided by the purchaser, Baumüller is responsible only for the fact that the manufactured product meets the specifications. Baumüller is not responsible for the usability of the product for the purposes the purchaser intends to use it for.
- 7.6 Excluded from warranty are shortcomings or defects caused by instructions/and or assembly not effected by Baumüller, insufficient equipment of the customer, overload of the components exceeding the capacity specified by Baumüller, negligent and improper treatment and utilization of unsuitable operating materials at the customer. This also applies to shortcomings or defects arising due to material provided by the customer. The warranty does not apply to damages caused by third parties, atmospheric discharges, overvoltages and chemical influences or to the replacement of parts which are exposed to natural wear. The warranty is void if the customer or a third party changes or repairs the units delivered without written permit by Baumüller.
- 7.7 In case of guarantee and/or warranty claims, the motor, the spare part or the unit shall be shipped free of duty and with free packing after prior agreement with Baumüller. Baumüller is freed of any warranty, if the customer returns the defective products without prior agreement or without observing the arrangements.
- 7.8 Baumüller is entitled to install spare parts and units into the plants of the customer for warranties to be fulfilled within the warranty period, in order to replace the defective products so that the efficiency of the customer's parts is affected as little as possible. The warranty period for installed spare parts and units is 6 months from the date of re-shipment at the customer. Taking into account the service time for the delivered products, the warranty period of 12 months from date of delivery acc. to item 7.2 remains unchanged.
8. Liability
- 8.1 Baumüller is liable for information and consulting activities on the utilization of the ordered and delivered products only with written confirmation in accordance with the below regulations. Verbal statements and information are not binding.
- 8.2 Claims for damages due to impossibility of performance, nondelivery, positive breach of obligations, culpa in contrahendo and unlawful act to Baumüller as well as to the persons employed in performing an obligation are excluded, if the damage has not been caused deliberately or grossly negligent or Baumüller is liable according to the product liability law.
9. Lump-sum damages in case of withdrawal
- 9.1 If the customer withdraws from the written order due to reasons for which Baumüller is not responsible, Baumüller is entitled to charge lump-sum damages of 50% of the net order amount. This applies also, if Baumüller withdraws from the contract due to reasons for which the customer is responsible.
10. Miscellaneous
- 10.1 Place of fulfillment and jurisdiction is Nuremberg. However, Baumüller is entitled to advance claims at the legal place of jurisdiction of the customer.
- 10.2 The legal regulations applicable in the Federal Republic of Germany are applicable to these conditions and terms of sales and delivery. The regulations or the UN law of sales are excluded.
- 10.3 If one or several regulations of these conditions and terms of sales and delivery are or become ineffective or if any arising situation and circumstances are not covered by this contract text, jurisdiction will replace or supplement the ineffective or incomplete stipulations by appropriate regulations corresponding to the economic purpose of the intended regulation to the largest possible extent. The validity of the other regulations remains unchanged.

9.3 Index

A

Accessories	36
Accuracy	11
Additional Parameter	191
Analog Inputs	147
Analog Outputs	151
Analog/Digital Interface	29
Appendix	207
Assembly	17
Assembly Note	18
Asynchronous Serial Interface	27

B

BAPS Communication	189
Basic Settings	42

C

Closed-Loop Control	12
Commands to Start the Drive	53
Commands to Stop the Drive	54
Commissioning	37
Conditions of Business and Delivery	208
Connection Cable RS485	33
Connector Pin Assignment	25
Control Word	117
Current Controller	94
Current Measurement and Monitoring	58
Current measurement and monitoring	58

D

Danger Information	19
Data Set Management	127
Deviation monitoring	106
Digital Inputs	156
Digital Outputs	161
Dimensions	17
Display	21
Drive Manager	109

E

Electrical Data	11
Encoder Evaluation	55
Encoder Manager	83
Encoder type	84
Ending Commissioning	48
Evaluation Encoder	86
External Digital input	164
External Digital Outputs	167

F

Field Angle Calculation	80
Following Axis	145
Function diagrams	55

I

Incremental Encoder Emulation	26
Initial Commissioning	40
Inputs	10
Installation	19
Installation of Operator Programs	40
Interface Adapter	34
Interfaces	11

L

Leading Axis	145
LED Display	153
LED Display Element	22
Locating Position Reference Point Setting	52

M

Maintenance	201
Maintenance information	201
Motor Model	69
Motor Potentiometer	140
Motor Temperature	28
Motor Temperature Monitoring	77

N

Number of Pole Pairs	80
----------------------	----

O

Operation Software	10
Operation system	133
Optional Boards	10
Outputs	10
Overload Monitoring	74
Overview V-Controller	56

P

PC Connection	31
Position Controller	103
Power Supply	59
Power Unit	61
Pulse Width Modulation	67

R

Ramp Function Generator	135
Rectangle Incremental Encoder	27
Resolver	26
RS232 Interface	25
RS485 Interface	25

S

Sampling Rate	11
Serial Connection Cable	31
Service Interface	170
Set Value Generator	138
Seven-segment Display	21
Sine Encoder	27
Sine Incremental Encoder 5V	27
Speed Control	47
Speed Controller	98
State Word	119
Synchronisation Control	142
Synchronous Operating Modes	145

T

Technical Data	9
Terminal Diagram	23
Torque Monitoring	101
Transportation	15
Transportation damage	15
Type Code	12

U

Unit Control State Machine	111
Unit Control State Transition	114
Unpacking	15
USS® Protocol	175

V

Version	12
---------	----

be in motion

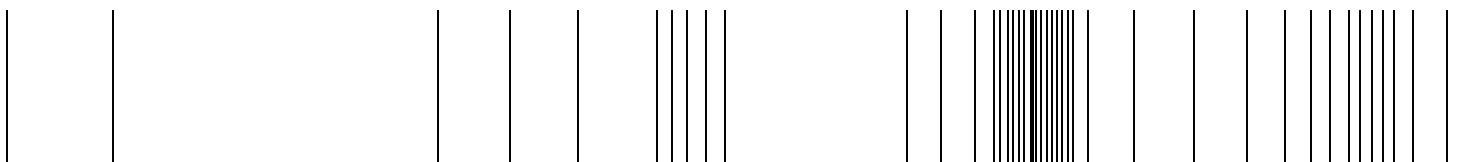

Baumüller Nürnberg GmbH Ostendstraße 80-90 90482 Nürnberg T: +49(0)911-5432-0 F: +49(0)911-5432-130 www.baumueller.de

All information given in this manual is customer information, subject to change without notice. We reserve the right to further develop and actualize our products continuously using our permanent revision service. Please notice, that specifications/data/information are current values according to the printing date. These statements are not legally binding according to the measurement, computation and calculations. Before you make any information given in this manual to the basis of your own calculations and/or applications, please make sure that you have the latest edition of the information in hand. No liability can be accepted concerning the correctness of the information.