

## Neslab RTE-7 Fan



Limited Availability  
Used and in Excellent Condition

Open Web Page

<https://www.artisanng.com/66866-10>

All trademarks, brandnames, and brands appearing herein are the property of their respective owners.



Your **definitive** source  
for quality pre-owned  
equipment.

**Artisan Technology Group**

(217) 352-9330 | [sales@artisanng.com](mailto:sales@artisanng.com) | [artisanng.com](http://artisanng.com)

- Critical and expedited services
- In stock / Ready-to-ship
- We buy your excess, underutilized, and idle equipment
- Full-service, independent repair center

Artisan Scientific Corporation dba Artisan Technology Group is not an affiliate, representative, or authorized distributor for any manufacturer listed herein.

Ideal for cooling and heating  
from -40°C to +200°C.

## Thermo Scientific NESLAB™ RTE and EX Series Bath Circulators



### Typical applications:

- Analytical instrumentation
- Calibration
- Condensers
- Gel electrophoresis
- Reaction vessels
- Rotary evaporators

### Robust, Compact Units

The Thermo Scientific NESLAB RTE Series of refrigerated bath circulators and NESLAB EX Series of heating bath circulators feature powerful cooling and heating, expansive temperature ranges, and sophisticated controller technology. These robust, compact units offer precise temperature stability and high reliability for external circulation and in-bath applications.

### Powerful Performance

An industrial-grade force and suction pump provides the pressure necessary to circulate fluid long distances to both open containers

and closed loop systems. This gives users the flexibility to meet a wide range of application needs.

### Precise Control

Both the NESLAB RTE and EX Series provide excellent agitation in the bath for improved uniformity and stability. The controller technology ensures that NESLAB RTE and EX systems perform at their peak.

### Economical Investment

NESLAB RTE and EX systems are smart investments. With capabilities that meet a wide range of application needs, these systems are designed for years of reliable service.



## Thermo Scientific NESLAB RTE Series

	NESLAB RTE 7	NESLAB RTE 10	NESLAB RTE 17	NESLAB RTE 740
<b>Process Fluid Temperature Range</b>				
115V/60 Hz Models	-25°C to +150°C	-25°C to +150°C	-24°C to +150°C	-40°C to +200°C
230V/50 Hz Models	-25°C to +150°C	-25°C to +150°C	-24°C to +150°C	-40°C to +200°C
100V/50-60Hz Model	-25°C to +150°C	-25°C to +150°C	-23°C to +150°C	-40°C to +200°C
<b>Temperature Stability</b>	±0.01°C	±0.01°C	±0.01°C	±0.01°C
<b>Cooling Capacity</b>				
60 Hz Models	500 watts @ 20°C	500 watts @ 20°C	500 watts @ 20°C	800 watts @ 20°C
50 Hz Models	500 watts @ 20°C	500 watts @ 20°C	500 watts @ 20°C	700 watts @ 20°C
<b>Heater</b>				
115V/60 Hz Models	800 watts	800 watts	1600 watts	800 watts
230V/50 Hz Models	2000 watts	2000 watts	2000 watts	2000 watts
100V/50-60Hz Model	800 watts	800 watts	1200 watts	800 watts
<b>Refrigerant</b>	R134a	R134a	R134a	R404a
<b>Bath Volume*</b>	7.0 liters (1.9 gallons)	11.3 liters (3.0 gallons)	18.1 liters (4.8 gallons)	7.0 liters (1.9 gallons)
<b>Pumping Performance</b>				
	15 LPM @ 0' head	15 LPM @ 0' head	15 LPM @ 0' head	15 LPM @ 0' head
	4 GPM @ 0' head	4 GPM @ 0' head	4 GPM @ 0' head	4 GPM @ 0' head
<b>Pump</b>	force/suction	force/suction	force/suction	force/suction
<b>Pump Head</b>	Max head 16' (4.9M)	Max head 16' (4.9M)	Max head 16' (4.9M)	Max head 16' (4.9M)
<b>Unit Dimensions (H x W x D)</b>	60.0 cm x 23.5 cm x 44.5 cm (23½ in x 9¼ in x 17½ in)	60.0 cm x 28.9 cm x 47.9 cm (23½ in x 11½ in x 18¾ in)	67.6 cm x 28.9 cm x 47.9 cm (26½ in x 11½ in x 18¾ in)	67.6 cm x 28.9 cm x 47.9 cm (26½ in x 11½ in x 18¾ in)
<b>Bath Opening/Depth (W x L x D)</b>	16.8 cm x 17.8 cm x 15.2 cm (6½ in x 7 in x 6 in)	22.4 cm x 20.6 cm x 15.2 cm (8¾ in x 8¼ in x 6 in)	22.4 cm x 20.6 cm x 22.9 cm (8¾ in x 8¼ in x 9 in)	16.8 cm x 17.8 cm x 15.2 cm (6½ in x 7 in x 6 in)
<b>Power Requirements</b>				
115V/60 Hz Models	12 amps	12 amps	16 amps	16 amps
230V/50 Hz Models	12 amps	12 amps	12 amps	12 amps
100V/50-60Hz Model	12 amps	12 amps	12 amps	12 amps
<b>Unit Weight</b>	27.0 kg (59.5 lb)	30.5 kg (67.3 lb)	31.9 kg (70.3 lb)	39.5 kg (87.0 lb)

Note: A remote sensor option allows you to control the temperature in an external vessel. The sensor comprises a resistance temperature detector (RTD) with a tether. The standard tether is 6 ft. long, and a variety of lengths and diameters are available to suit most any application need. Stability, pump performance and cooling capacity specifications to +5°C were determined using water. Other specifications were determined using fluid with specific heat of 0.6, ambient +20°C. We do not recommend the use of flammable liquids. Specifications subject to change without notice.

\* Bath reservoir volume is measured to midpoint of designated fill lines.

### NESLAB RTE Dimensional Diagram

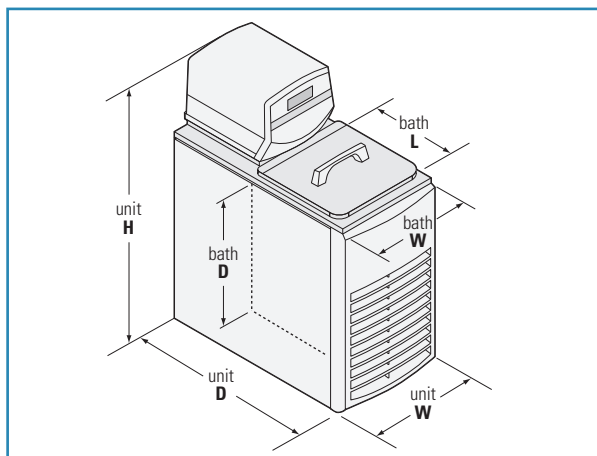

### 115 V Electrical Configurations



20 Amp Outlet  
(16 Amp)



15 Amp Outlet  
(12 Amp)

**NESLAB RTE Series Pumping Capacity**

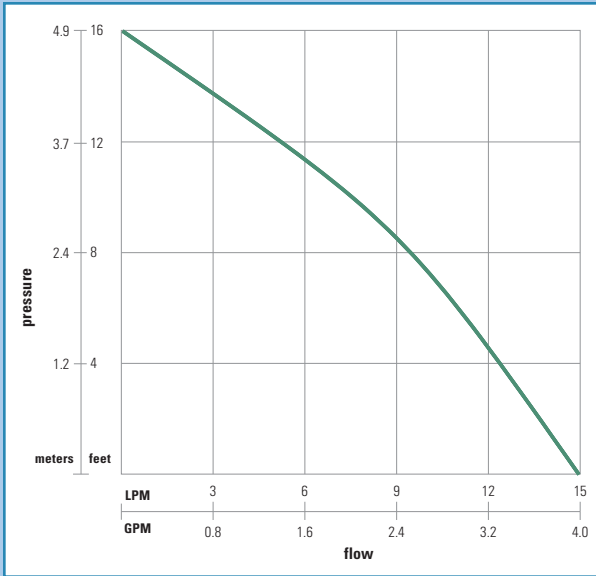

**Performance Curve for NESLAB RTE 740**

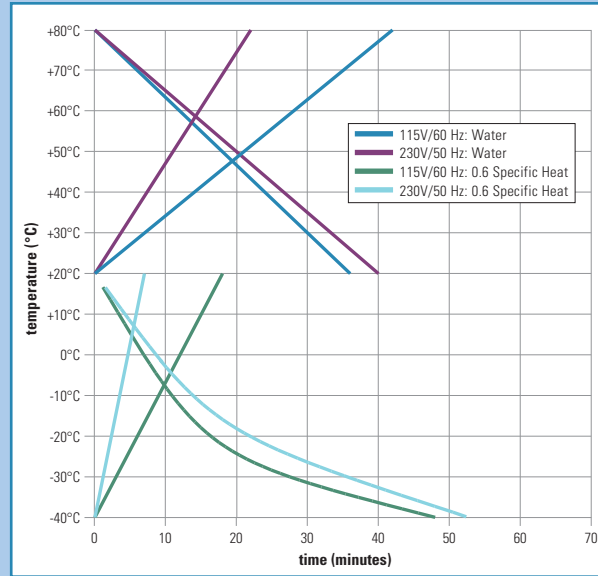

**NESLAB RTE Series Cooling Capacity**

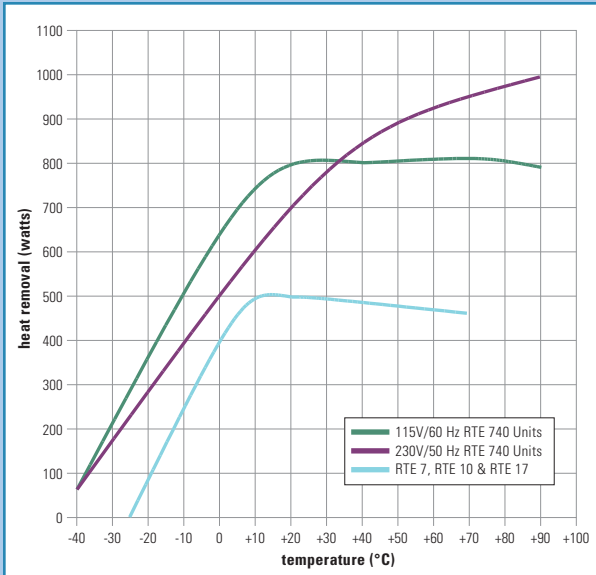

**Performance Curve for NESLAB RTE 7, 10, 17 230V/50 Hz Units**

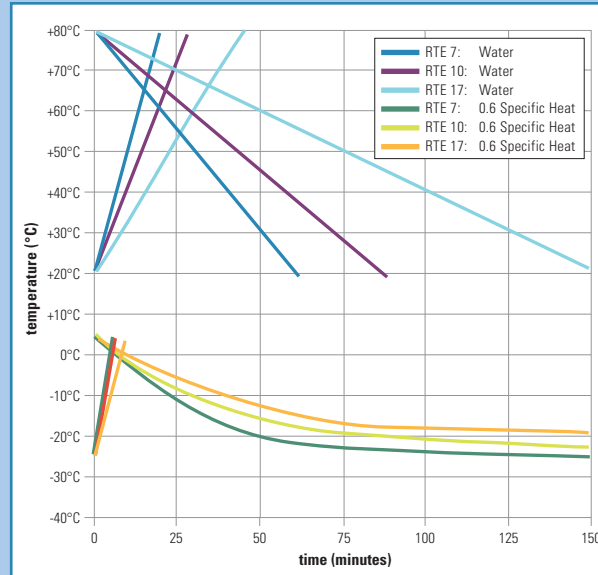

**Performance Curve for NESLAB RTE 7, 10, 17 115V/60 Hz Units**

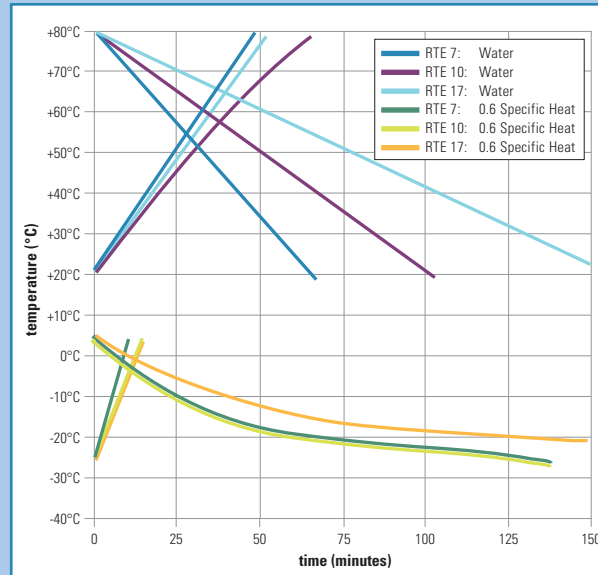



## Thermo Scientific NESLAB EX Series

	NESLAB EX 7	NESLAB EX 10	NESLAB EX 17	NESLAB EX 35
<b>Process Fluid Temperature Range</b>	Ambient +12°C to 200°C	Ambient +12°C to 200°C	Ambient +12°C to 200°C	Ambient +12°C to 200°C
<b>Temperature Stability</b>	±0.01°C	±0.01°C	±0.01°C	±0.01°C
<b>Heater</b>				
115V/60 Hz Models	800 watts	800 watts	1600 watts	800 watts
230V/50 Hz Models	2000 watts	2000 watts	2000 watts	2000 watts
100V/50-60Hz Model	800 watts	800 watts	1200 watts	1200 watts
<b>Bath Volume*</b>	7.0 liters (1.9 gallons)	11.3 liters (3.0 gallons)	18.1 liters (4.8 gallons)	36.3 liters (9.6 gallons)
<b>Pumping Performance</b>				
	15 LPM @ 0' head	15 LPM @ 0' head	15 LPM @ 0' head	15 LPM @ 0' head
	4 GPM @ 0' head	4 GPM @ 0' head	4 GPM @ 0' head	4 GPM @ 0' head
<b>Pump</b>				
	force/suction	force/suction	force/suction	force/suction
<b>Pump Head</b>	Max head 16' (4.9M)	Max head 16' (4.9M)	Max head 16' (4.9M)	Max head 16' (4.9M)
<b>Unit Dimensions (H x W x D)</b>				
	37.1 cm x 23.5 cm x 44.5 cm (14½ in x 9¼ in x 17½ in)	37.1 cm x 28.9 cm x 46.4 cm (14½ in x 11½ in x 18¼ in)	44.8 cm x 28.9 cm x 46.4 cm (17½ in x 11½ in x 18¼ in)	52.4 cm x 28.9 cm x 64.5 cm (20¾ in x 11½ in x 25½ in)
<b>Bath Opening/Depth (W x L x D)</b>				
	16.8 cm x 17.8 cm x 15.2 cm (6½ in x 7 in x 6 in)	22.4 cm x 20.6 cm x 15.2 cm (8¾ in x 8¼ in x 6 in)	22.4 cm x 20.6 cm x 22.9 cm (8¾ in x 8¼ in x 9 in)	22.4 cm x 39.4 cm x 30.5 cm (8¾ in x 15½ in x 12 in)
<b>Power Requirements</b>				
115V/60 Hz Models	9 amps	9 amps	16 amps	16 amps
230V/50 Hz Models	10 amps	10 amps	10 amps	10 amps
100V/50-60Hz Model	10 amps	10 amps	10 amps	10 amps
<b>Unit Weight</b>	12.0 kg (26.4 lb)	14.5 kg (32.0 lb)	16.2 kg (35.6 lb)	23.8 kg (52.7 lb)

*Note: Stability, pump specifications to +90°C were determined using water. Other specifications were determined with silicon oil. Reservoir volume measured to midpoint of designated fill line. Bath opening measured to tank top. Flammable fluids should never be used with these units. Specifications subject to change without notice.*

*\* Bath reservoir volume is measured to midpoint of designated fill lines.*

### NESLAB EX Dimensional Diagram

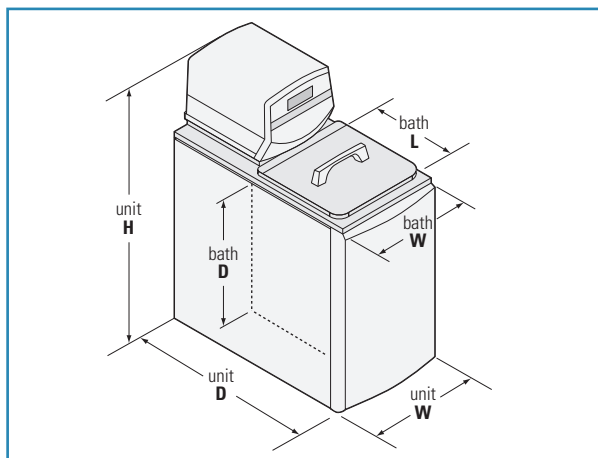

### 115 V Electrical Configurations



**20 Amp Outlet  
(16 Amp)**



**15 Amp Outlet  
(12 Amp)**

NESLAB EX Series Pumping Capacity

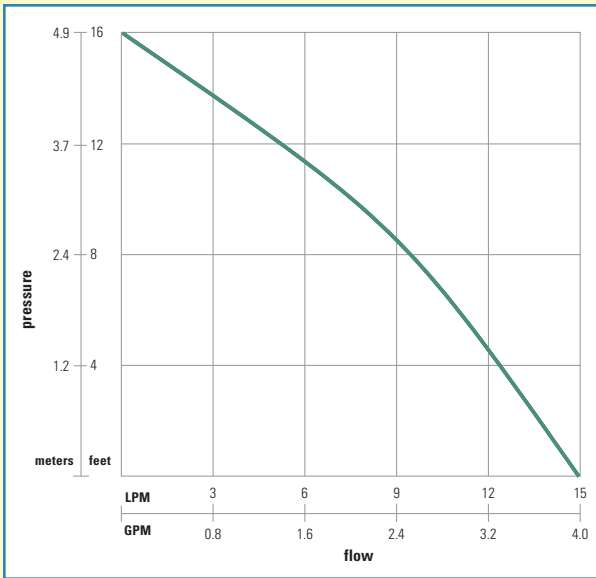

NESLAB EX Series Performance Curve — Ramp Up 230V/50 Hz Units

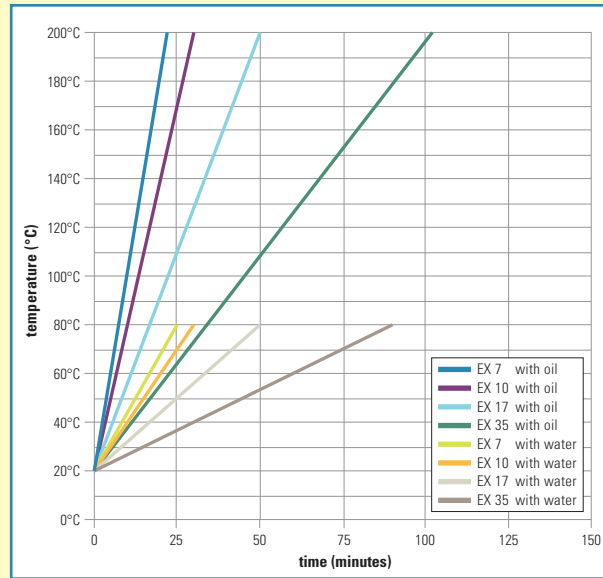

NESLAB EX Series Performance Curve — Ramp Up 115V/60 Hz Units

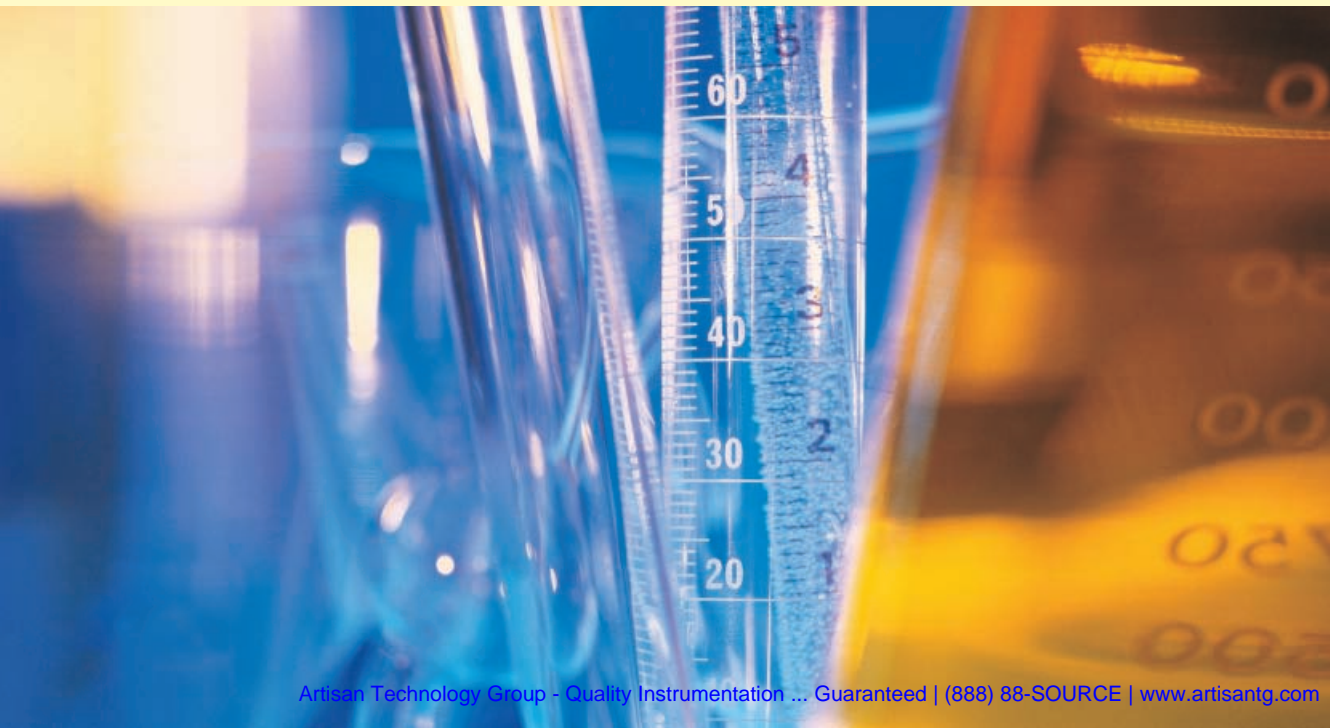
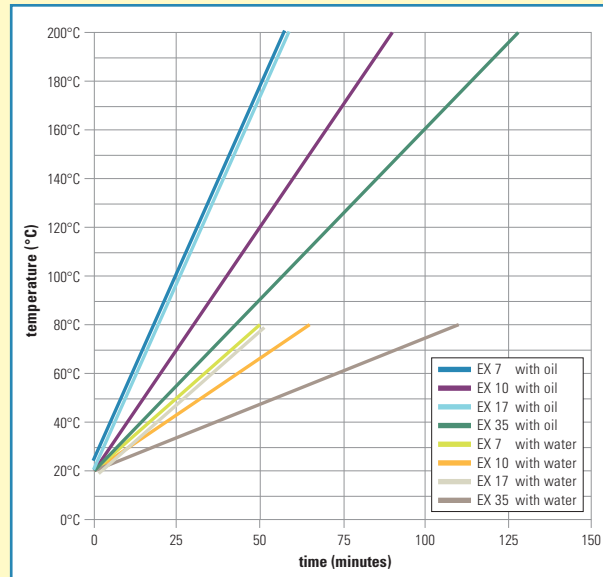

Feature	Benefit
Full Range Cooling (RTE Series only)	Allows compressor to operate over entire temperature range.
Front Grille (RTE Series only)	Allows quick access to the condenser for routine cleaning.
Refrigeration System (RTE Series only)	Provides CFC-free refrigeration system for precise temperature control and optimum stability.
Energy Savings Mode (RTE Series only)	Minimizes heater power needs to substantially reduce energy costs over the life of a unit.
Nitrogen Purge Port (RTE Series only)	Eliminates condensation when operating below ambient.
Tap Water Cooling Coil (EX Series only)	Maintains temperatures near ambient or for rapid cool down from elevated temperatures.
Circulating Pump	Combines a strong flow rate with unmatched pressure to circulate farther, even through small. I.D. tubing delivering consistent flow when working with dense or viscous fluids.
Force and Suction Pump	Provides versatility of circulating through a closed system, open system, or two applications.
Heater	Powerful heater for rapid time to temperature.
Stainless Steel Bath	Convenient, easy cleaning. Compatible with a wide range of fluids.
Hydro-Seal Lid	Limits evaporation/condensation.
Bath Drain	Allows for fast fluid changes.
Digital Temperature Controller	Provides precise setpoint and readout to a resolution of 0.01°C.
Low-Level Shut-Off Device	Prevents unit damage and protects your application.
RS-232 and RS-485 (option)	Connects directly to computer.
Compact Design	Maximizes valuable benchtop space.
Digital Display	Offers the user a simple operation and ensures accuracy and reproducibility of procedures.
Two-Year Warranty	Offers peace of mind.



#### Digital One

- Bright LED digital display
- User selectable resolution 0.1°C or 0.01°C
- User adjustable low temperature and high temperature alarm limits
- User selectable fault conditions
  - Continuous run with visual alert
  - Shut down with visual alert
- Compatible with optional auto-refill device
- Low reservoir fluid level shut-off



#### Digital Plus

Same great features as the Digital One controller plus we've added:

- Remote sensor port
- RS-232 and RS-485 communications ports
- On/off timer with clock
- Audible safety alarm with mute
- Temperature offset display



#### Digital Plus with Analog I/O Port

Same great features as the Digital Plus with the added ability to communicate via analog (voltage) signal to:

- Monitor set point
- Change set point
- Monitor fault status

**Thermo Scientific NESLAB NEScom Software**

NESLAB NEScom software allows you to easily program and automate your entire temperature control process from a PC.

**RPC Remote Programming Controller**

The RPC remote programming controller transforms your Digital Plus controller into one of the most feature-packed controllers available. The easy-to-read, 120 mm x 90 mm touchscreen uses icons for quick function selection. Includes an RS-232 port for future software upgrade. Comes complete with wall-mounting bracket, power cord and 6-ft connector cable.

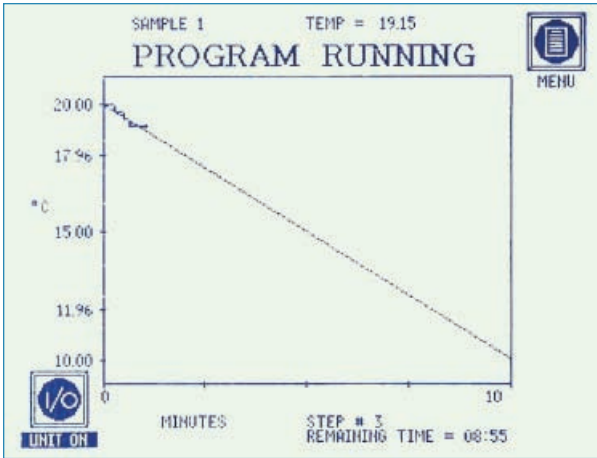

**RPC Chart Screen**

- Visual graph of current ramp step

STEP	START TEMP	END TEMP	TIME (MIN)	# OF LOOPS	LOOP TO STEP	STATUS
1	20.00	25.00	10			
2	25.00	20.00	10	3		
3	20.00	10.00	10		2	

PROGRAM NO: 1      NAME: SAMPLE 1

**PROGRAM RUNNING**

STEP INFO  
REMAINING TIME = 08:57

STEP ADVANCE

PAUSE      STOP      ASSURED SOAK ON

**RPC Program Running Screen — Multistep Programming**

- 16 savable programs with alphanumeric naming
- 16 steps per program
- Time range of up to 6500 minutes per step
- Step looping
- Step to function
- Simple spreadsheet format

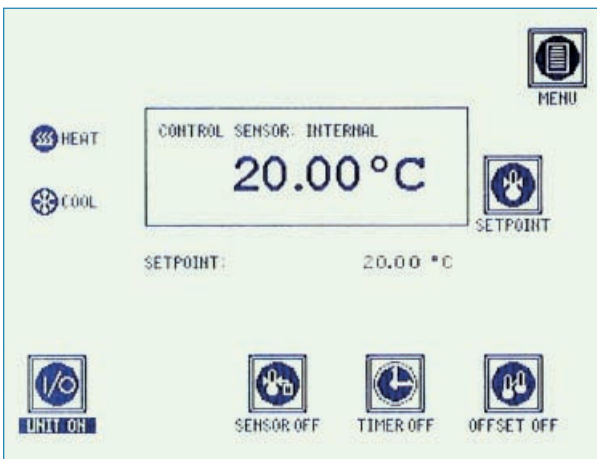

**RPC Main Screen — Monitor, Control and Change**

- Internal sensor temperature
- Temperature setpoint
- Remote sensor temperature
- On/off timer
- Temperature offset
- Temperature alarm limits
- Readout resolution



## Thermo Scientific NESLAB RTE and EX Series Accessories

### Reservoir Refill System

Attaches easily to the rear of the unit to conserve space. Runs your equipment worry free and unattended. Automatically refills your bath from a pressurized fluid source when the fluid in the bath drops below an acceptable limit due to evaporation. Specify voltage requirements.

### Anti Reservoir Overflow Device

Connects to your bath circulator's drain line to prevent an accidental overflow of fluid in the reservoir.

### Remote Sensors

Allow remote temperature control of the application and will maintain the setpoint at any place in the recirculating fluid path. The sensors are platinum RTDs and are compatible with the bath circulators when used with a Digital Plus Controller. Different diameters and lengths are available.

### Plumbing Kit — Tygon

Allows circulation between -25°C and +100°C and includes 25 ft of tygon tubing, 25 ft of tubing insulation, and four hose clamps.

### Plumbing Kit — Silicone

Allows circulation between -100°C and +100°C and includes 25 ft of silicone tubing, 25 ft of tubing insulation, and four hose clamps.

### Test Tube Racks

Offers convenient handles for easy and safe placement or removal. Made of stainless steel for durability.

### Stainless Steel Leveling Device\*

Ensures that the fluid level in the external container remains constant.

### Flow Controller\*\*

Quick and easy set up for external circulation to open container.

### Ground Fault Circuit Controller

Plugs your unit into the GFCI accessory to provide extra electrical protection when a GFCI wall outlet is not available. May only be used with 115 Volt, 60 Hz units.

### Ethylene Glycol

Allows circulation to temperatures down to -30°C in a 50/50 blend when mixed with water.

### Chloramine-T Algicide

Restricts growth of algae to protect equipment and instrumentation.

### Silicone Oil

Designed for use in high temperature applications from +35°C to +150°C.

\* Used with standard ring stand

\*\* Necessary to operate stainless steel leveling device

## About Thermo Fisher Scientific

Thermo Fisher Scientific (NYSE: TMO) is the world leader in serving science, enabling our customers to make the world healthier, cleaner and safer. With annual revenues of \$10 billion, we have more than 30,000 employees and serve over 350,000 customers within pharmaceutical and biotech companies, hospitals and clinical diagnostic labs, universities, research institutions and government agencies, as well as environmental and industrial processing settings. Serving our customers through two premier brands, Thermo Scientific and Fisher Scientific, we help solve analytical challenges from routine testing to complex research and discovery. Thermo Scientific offers customers a complete range of high-end analytical instruments as well as laboratory equipment, software, services, consumables and reagents to enable integrated laboratory workflow solutions. Fisher Scientific provides a complete portfolio of laboratory equipment, chemicals, supplies and services used in healthcare, scientific research, safety and education. Together, we offer the most convenient purchasing options to customers and continuously advance our technologies to accelerate the pace of scientific discovery, enhance value for customers and fuel growth for shareholders and employees alike. Visit [www.thermofisher.com](http://www.thermofisher.com).

© 2008 Thermo Fisher Scientific Inc. All rights reserved. All trademarks are the property of Thermo Fisher Scientific Inc. and its subsidiaries. Results may vary under different operating conditions. Specifications, terms and pricing are subject to change. Not all products are available in all countries. Please consult your local sales representatives for details. Literature Code PSRTEEXv3.0E05/08TC

Benelux  
+31 (0) 76 5 79 55 55  
[info.tc.nl@thermofisher.com](mailto:info.tc.nl@thermofisher.com)

China  
+86 (21) 68 65 45 88  
[info.tc.china@thermofisher.com](mailto:info.tc.china@thermofisher.com)

France  
+33 (0) 1 60 92 48 00  
[info.tc.fr@thermofisher.com](mailto:info.tc.fr@thermofisher.com)

Germany  
+49 (0) 721 4 09 44 44  
[info.tc.de@thermofisher.com](mailto:info.tc.de@thermofisher.com)

India  
+91 (22) 27 78 11 01  
[info.tc.in@thermofisher.com](mailto:info.tc.in@thermofisher.com)

United Kingdom  
+44 (0) 870 609 9254  
[info.tc.uk@thermofisher.com](mailto:info.tc.uk@thermofisher.com)

USA  
+1 (603) 436-9444  
[info.tc.us@thermofisher.com](mailto:info.tc.us@thermofisher.com)

# Artisan Technology Group is an independent supplier of quality pre-owned equipment

## Gold-standard solutions

Extend the life of your critical industrial, commercial, and military systems with our superior service and support.

## We buy equipment

Planning to upgrade your current equipment? Have surplus equipment taking up shelf space? We'll give it a new home.

## Learn more!

Visit us at [artisanng.com](http://artisanng.com) for more info on price quotes, drivers, technical specifications, manuals, and documentation.

Artisan Scientific Corporation dba Artisan Technology Group is not an affiliate, representative, or authorized distributor for any manufacturer listed herein.

We're here to make your life easier. How can we help you today?

(217) 352-9330 | [sales@artisanng.com](mailto:sales@artisanng.com) | [artisanng.com](http://artisanng.com)

